

Vane pumps type PFE-32, PFE-42, PFE-52

fixed displacement - high pressure and/or low noise level execution

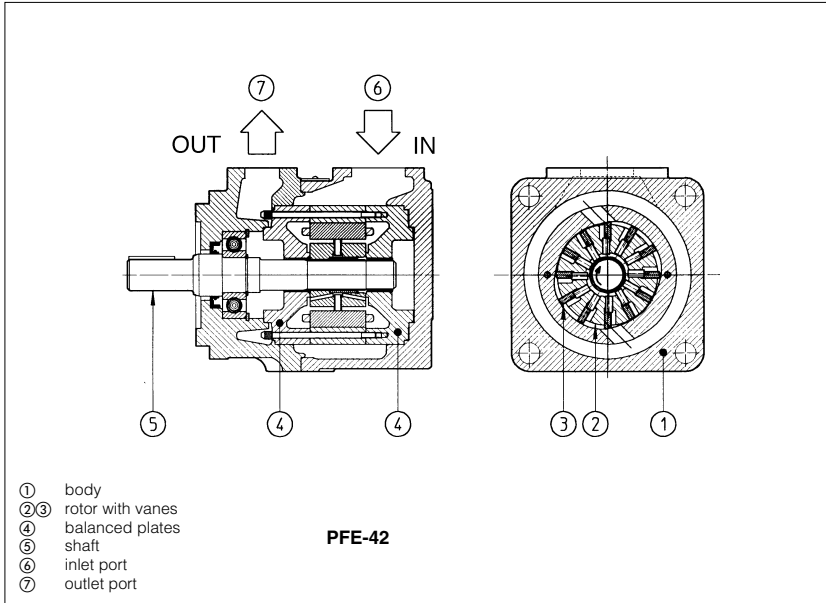

New PFE-*2 are fixed displacement -twelve-vanes pumps (2)(3), cartridge design with integral hydraulic balancing (4) for high pressure operation and long service life with further reduction of noise level compared with PFE-*1.

Suitable for hydraulic oils according to DIN 51524... 535 or synthetic fluids having similar lubricating characteristics.

These pumps are available as single, multiple or with through-shaft configuration.

Mounting according to SAE standard. Easy installation as inlet and outlet ports can be assembled in any of four relative positions.

Easy maintenance as the pumping cartridge can be replaced in a few minutes.

Wide variety of displacements up to 150 cm³/rev.

Max pressures up to 300 bar.

1 MODEL CODE

PFE	X2	- 42	045	/31028	/ 3	D	T	**	/*
Fixed displacement vane pump									Synthetic fluids: WG = water-glycol PE = phopsphate ester
Additional suffix for multiple pumps: X2 = double pump composed of single vane pumps X3 = triple pump composed of single vane pumps Additional suffix for pumps with through shaft: XA = for coupling one PFE-31 XB = for coupling one PFE-41 (only for PFE-42 and PFE-52) XC = for coupling one PFE-51 (only for PFE-52) XO = with through shaft, without rear flange Note: multiple pumps are assembled in decreasing order of size. See also tab. A190.								Design number	
Size, see section 2: 32, 42, 52								Port orientation, see section 5: T = standard U, V, W = on request	
Displacement [cm ³ /rev], see section 2: for PFE 32: 022, 028, 036 for PFE 42: 045, 056, 070, 085 for PFE 52: 090, 110, 129, 150								Direction of rotation (viewed from the shaft end): D = clockwise (supplied standard if not otherwise specified) S = counterclockwise Note: PFE are not reversible and it is therefore necessary to specify the desired direction of rotation	
Only for multiple pumps PFE*: type of second (and third) pump								Drive shaft, see section 6 and 7: cylindrical, keyed for single and multiple pump (only first position) 3 = for high torque applications splined 5 = for single and multiple pumps (any position) 6 = for single and multiple pumps (only first position) } only for PFE-32 and PFE-42 7 = for second and third position in multiple pumps	

2 OPERATING CHARACTERISTICS at 1450 rpm (based on mineral oil ISO VG 46 at 50°C)

Model	Displacement cm ³ /rev	Max pressure (1)	Speed range rpm (2)	7 bar (3)		140 bar (3)		at max. pressure (3)	
				l/min	kW	l/min	kW	l/min	kW
PFE-32022	21,6	300 bar	1200-2500	30	0,6	26	7	20	16
PFE-32028	28,1			40	0,8	36	10	30	20
PFE-32036	35,6			51	1	46	12,5	40	26
PFE-42045	45	280 bar	1000-2200	64	1,3	60	16	56	31
PFE-42056	55,8			80	1,6	75	21	70	40
PFE-42070	69,9	250 bar	800-2000	101	2	95	26	90	42
PFE-42085	85,3	210 bar		124	2,4	118	32	114	43
PFE-52090	90	250 bar		1000-2000	128	2,7	119	33	111
PFE-52110	109,6		157		3,2	147	40	138	66
PFE-52129	129,2		186		3,7	174	47	163	78
PFE-52150	150,2		215		4,2	204	55	197	80

(1) Max pressure is 160 bar for /PE and /WG versions
 (2) Max speed is 1800 rpm for /PE versions; 1500 rpm for /WG versions
 (3) Flow rate and power consumption are proportional to the rotation speed

3 MAIN CHARACTERISTICS OF VANE PUMPS TYPE PFE-*2

Installation position	Any position.		
Loads on the shaft	Axial and radial loads are not allowed on the shaft. The coupling should be sized to absorb the power peaks.		
Ambient temperature	from -20°C to +70°C		
Fluid	Hydraulic oil as per DIN 51524...535; for other fluids see section I		
Recommended viscosity	max at cold start max at full power during operation min at full power	800 mm ² /s 100 mm ² /s 24 mm ² /s 10 mm ² /s	
Fluid contamination class	ISO 19/16 (filters at 25 µm value with β ₂₅ ≥ 75 recommended)		
Fluid temperature	-20°C +60°C	-20°C +50°C (/WG seals)	-20°C +80°C (/PE seals)
Recommended pressure on inlet port	from 0 to 1,5 bar		

4 DIAGRAMS (based on mineral oil ISO VG 46 at 50°C)

1 = Torque versus pressure diagram

2 = Noise level measured with ambient conditions according to ISO 4412-1 standards.
Shaft speed: 1450 rpm.

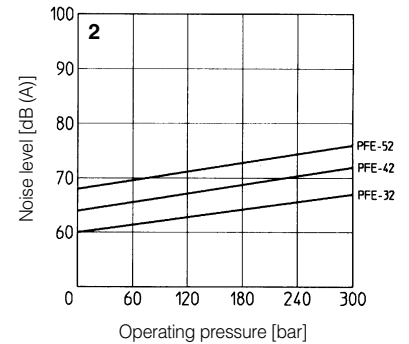
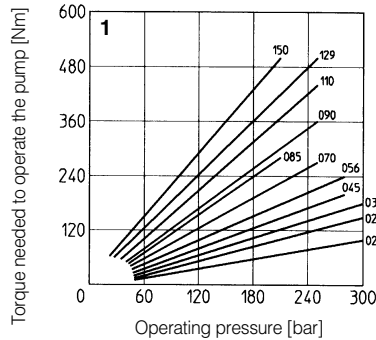

PFE-32:

3 = Flow versus speed diagram with pressure variation from 7 bar to 210 bar.

4 = Power consumption versus speed diagram at 140 bar. Power consumption is proportional to operating pressure.

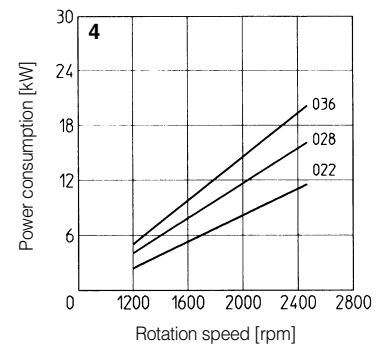
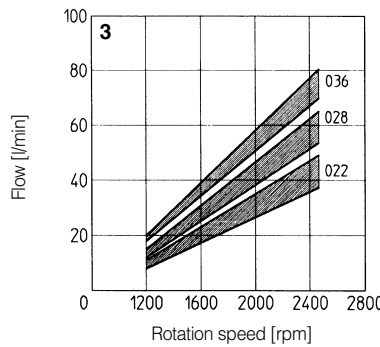

PFE-42:

5 = Flow versus speed diagram with pressure variation from 7 bar to 210 bar.

6 = Power consumption versus speed diagram at 140 bar. Power consumption is proportional to operating pressure.

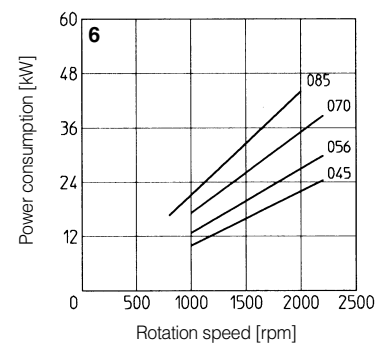
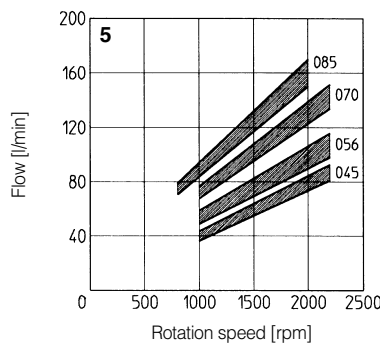

PFE-52:

7 = Flow versus speed diagram with pressure variation from 7 bar to 210 bar.

8 = Power consumption versus speed diagram at 140 bar. Power consumption is proportional to operating pressure.

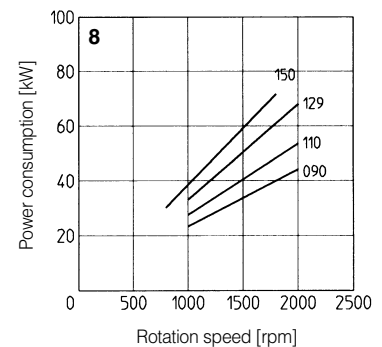
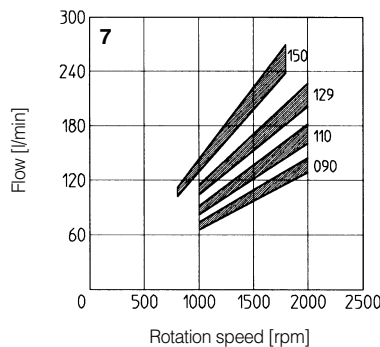

5 PORT ORIENTATION

Single pumps can be supplied with oil ports oriented in different configuration in relation to the drive shaft, as follows (viewed from the shaft end);
T = inlet and outlet ports on the same axis (standard)
U = outlet orientated 180° with respect to the inlet
V = outlet oriented 90° with respect to the inlet
W = outlet oriented 270° with respect to the inlet
 In multiple pumps inlet ports and outlet ports are in line.
 Ports orientation can be easily changed by rotating the pump body that carries inlet port.

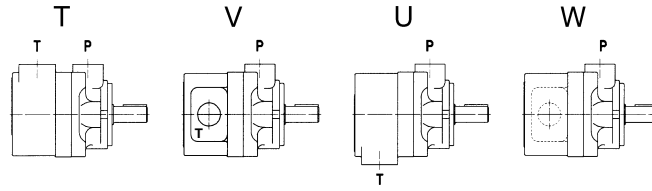

6 DRIVE SHAFT

CYLINDRICAL KEYED SHAFT

3 = for single and multiple pumps (only first position)
 for high torque applications

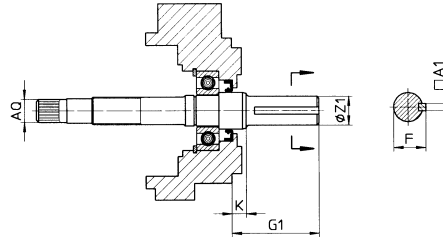

Model	Keyed shaft type 3					Only for through shaft execution Ø AQ
	A1	F	G1	K	ØZ1	
PFE-32	4,76	24,54	55,6	9,50	22,22	SAE 16/32-9T
	4,75	24,41			22,20	
PFE-42	6,36	28,30	78,00	11,40	25,38	SAE 32/64-24T
	6,35	28,10			25,36	
PFE-52	7,95	38,58	84,00	14	34,90	SAE 16/32-13T
	7,94	38,46			34,88	

SPLINED SHAFT

5 = for single and multiple pumps (any position)
 for PFE-32 according to SAE A 16/32 DP, 9 teeth;
 for PFE-42 according to SAE B 16/32 DP, 13 teeth;
 for PFE-52 according to SAE C 12/24 DP, 14 teeth;
6 = for single and multiple pumps (only first position)
 for PFE-32 and PFEX*-32 according to SAE B 16/32 DP, 13 teeth;
 for PFE-42 and PFEX*-42 according to SAE C 12/24 DP, 14 teeth;
7 = for second and third position pump in multiple configuration:
 for PFEX*-32 according to SAE B 16/32 DP, 13 teeth;
 for PFEX*-42 according to SAE C 12/24 DP, 14 teeth;

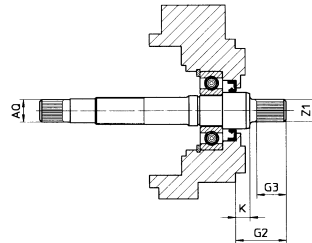

Model	Splined shaft type 5					Splined shaft type 6					Splined shaft type 7				
	G2	G3	K	Z1	Only for through shaft execution Ø AQ	G2	G3	K	Z1	Only for through shaft execution Ø AQ	G2	G3	K	Z1	Only for through shaft execution Ø AQ
PFE-32	33,50	19,50	9,50	SAE 16/32-9T	SAE 16/32-9T	42,50	28	9,50	SAE 16/32-13T	SAE 16/32-9T	33,50	19	9,50	SAE 16/32-13T	SAE 16/32-9T
PFE-42	41,25	28	8,00	SAE 16/32-13T	SAE 32/64-24T	55,60	42	8,00	SAE 12/24-14T	SAE 32/64-24T	41,60	28	8,00	SAE 12/24-14T	SAE 32/64-24T
PFE-52	56,00	42	8,10	SAE 12/24-14T	SAE 16/32-13T	-	-	-	-	-	-	-	-	-	-

7 LIMITS OF SHAFT TORQUE

Pump model	Maximum driving torque [Nm]				Maximum torque available at the end of the through shaft [Nm]
	Shaft type 3	Shaft type 5	Shaft type 6	Shaft type 7	
PFE-32	240	110	240	240	130
PFE-42	400	200	400	400	250
PFE-52	850	450	-	-	400

The values of torque required to operate the pumps are shown for each type on the "torque versus pressure diagram" at section 4.
 In multiple pumps the total torque applied to the shaft of the first element (drive shaft) is the sum of the single torque needed for operating each single pump and it is necessary to verify that this total torque applied to the drive shaft is not higher than the values indicated in the table.

8 DIMENSIONS OF SINGLE PUMPS [mm]

T = inlet port
P = outlet port

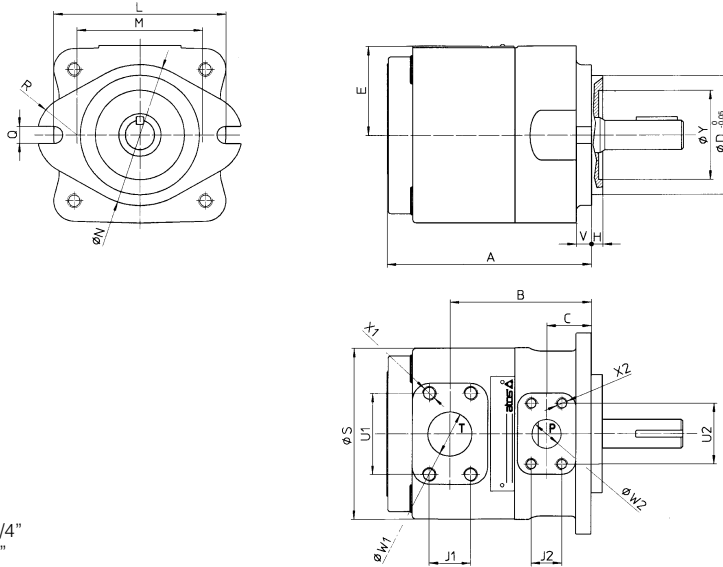

SAE FLANGES

PFE-32: port T = 1 1/4"; port P = 3/4"
PFE-42: port T = 1 1/2"; port P = 1"
PFE-52: port T = 2; port P = 1 1/4"

Mass:
PFE-32 = 9 kg
PFE-42 = 20,5 kg
PFE-52 = 32,1 kg

Flanges SAE-3000 can be supplied with the pump, see tab. K120

Model	A	B	C	ØD	E	H	L	M	ØN	Q	R
PFE-32	134,5	98,5	27,5	82,5	70	6,4	106	73	95	11,1	28,5
PFE-42	175,5	120	38	101,6	78	9,7	146	107	120	14,3	34
PFE-52	189	125	38	127	89	12,7	181	143,5	148	17,5	35
Model	ØS	U1	U2	V	ØW1	ØW2	J1	J2	X1	X2	ØY
PFE-32	114	58,7	47,6	10	32	19	30,2	22,2	M10X20	M10X17	47
PFE-42	134	70	52,4	13	38	25	35,7	26,2	M12X20	M10X17	76
PFE-52	158	77,8	58,7	15	51	32	42,9	30,2	M12X20	M10X20	76

9 DIMENSIONS OF PUMPS WITH THROUGH-SHAFT (FOR MULTIPLE PUMPS) [mm]

T = inlet port
P = outlet port

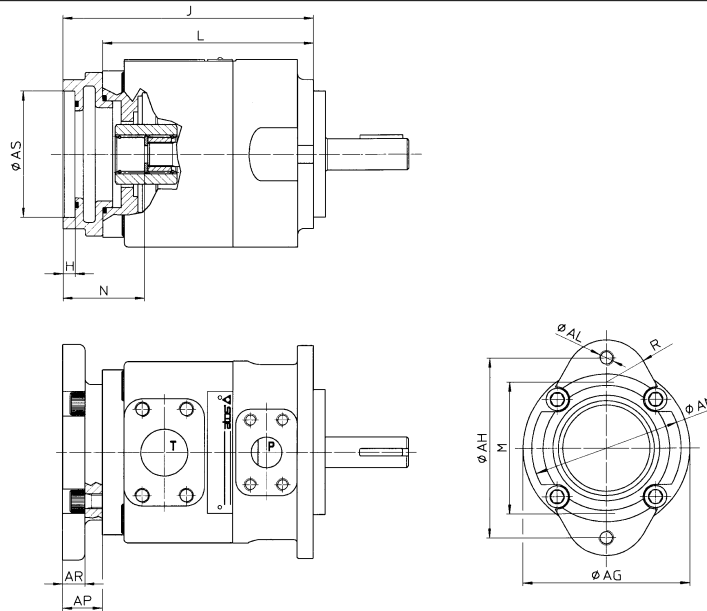

For other dimensions, see section 8

Model	Ø AG	Ø AH	AL	Ø AN	AP	AR	Ø AS	H	J	L	M	N	R
PFEXA-32	114	106	M10X17	95	33	25	82,57 82,63	6,42 6,48	164	131	79	32	28,5
PFEXA-42	134	106	M10X17	95	23	11	82,57 82,63	6,48 6,48	194	171	73	32	28,5
PFEXB-42	134	146	M12	120	32	18	101,62 101,68	9,73 9,78	203	171	107	41	34
PFEXA-52	134	106	M10X17	95	22,7	11	82,57 82,63	6,42 6,43	206,2	183,5	73	32	28,5
PFEXB-52	134	146	M12	120	32	18	101,62 101,68	9,73 9,78	215,5	183,5	107	41	34
PFEXC-52	134	181	M16	148	46,5	30,7	127,02 127,02	12,73 12,78	230	183,5	143,5	56	35