

Hydraulic cylinders type **CH** • big bore size

ISO 6020-3 standard

double acting - nominal pressure 160 bar - maximum pressure 250 bar

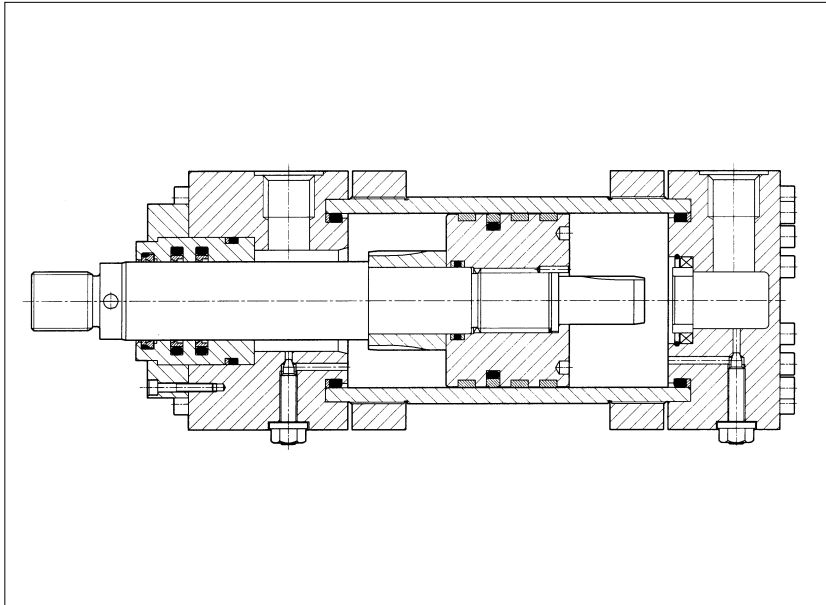

- Three bore diameters from 250 to 400 mm.
 - Round heads with counterflange (tie-rods for mid-body trunnion attachment).
 - Strokes on request.
 - According to ISO 6020-3 standard.
 - Rods with standard heavy chrome-plating (thickness min. = 0.045 mm).
 - Guides designed with abundant overload margin.
 - Seals with seats to ISO 7425.
- Available options: air bleeds, adjustable cushioning devices.
 - Also in version with built-in position transducer - see tab. B310.
 - Rod attachments: see tab. B500.

1 MODEL CODE

CH	P	250 / 140/140	* 0500	- S	3	0	8	A	10																				
<p>Cylinder series</p> <p>CH = ISO 6020-3 standard nominal pressure:160 bar max. pressure:250 bar</p> <p>Eventual transducer for servocylinders: P = potentiometric M = magnetosonic V = inductive Dimension and performance: see tab. B310</p> <p>Bore diameter [mm]</p> <p>Rod (rods) diameter [mm] Report the second dimension only for double-rod cylinders</p> <p>Stroke [mm] Max. stroke 5000 mm. For longer strokes consult our technical office. For tolerances and further information see tab. B005.</p> <p>Ports - sect. 4 ISO ref.</p> <table border="0"> <tr> <td>C = female clevis</td> <td>MP1</td> <td>*</td> </tr> <tr> <td>G = front-body trunnion</td> <td>MT1</td> <td></td> </tr> <tr> <td>L = mid-body trunnion</td> <td>MT4</td> <td></td> </tr> <tr> <td>N = front flange</td> <td>MF5</td> <td></td> </tr> <tr> <td>P = rear flange</td> <td>MF6</td> <td>*</td> </tr> <tr> <td>S = swivel attachment eye</td> <td>MP5</td> <td>*</td> </tr> <tr> <td>X = basic execution</td> <td>—</td> <td></td> </tr> </table> <p>*: not available for double-rod versions. In double-rod versions the codes of the attachments are relative to rod 1.</p>	C = female clevis	MP1	*	G = front-body trunnion	MT1		L = mid-body trunnion	MT4		N = front flange	MF5		P = rear flange	MF6	*	S = swivel attachment eye	MP5	*	X = basic execution	—								<p>Drawing number Always indicate the drawing number of the label in case you require spare parts</p> <p>Options: to report in alphabetical order</p> <p>ROD PROCESSING: K = NIKROM = 350 h resistance in saline mist up to ISO 3768. Consult our technical office T = hardening and chromeplating. For other features see tab. B005.</p> <p>FURTHER OPTIONS: A = front air-bleed; W = rear air-bleed;</p> <p>Seals:</p> <p>8 = (NITRILE+PTFE) anti-friction, for speed up to 1 m/sec; for mineral oil, water-glycol and organic esters based fluids. 2 = (VITON+PTFE) anti-friction, for high fluid temperatures, for speed up to 1 m/sec; for mineral oil, water-glycol and phosphate ester based fluids. For other characteristics, see tab. B005. Consult our technical office for other typologies and/or rod-draining.</p> <p>Spacers: 2 = 50 mm - 4 = 100 mm - 6 = 150 mm - 8 = 200 mm. See note at sect. 2 for the dimensions recommended up to the stroke. For further information see tab. B005</p> <p>Cushioning: 0 = none 1 = rear only 2 = front only 3 = front end rear For construction characteristics and performances see tables B005 and B015.</p>	
C = female clevis	MP1	*																											
G = front-body trunnion	MT1																												
L = mid-body trunnion	MT4																												
N = front flange	MF5																												
P = rear flange	MF6	*																											
S = swivel attachment eye	MP5	*																											
X = basic execution	—																												

2 DIMENSIONS [mm] - see drawing sect. **3**, **4**

Ø PISTON	250	320	400
Ø ROD	140	180	220
A	112	125	160
B F9	163	205	245
CB A16	90	110	140
CD H9	90	110	140
CH	15	15	15
CX H7	125	160	200
D	58	58	69
E	320	400	500
EE	1 1/2"	1 1/2"	2"
EP	102	130	162
EX	125	160	200
F max	75	75	75
FB	30	36	45
J	45	56	80
KK	M100x3	M125x4	M160x4
L	125	152	195
Lf	58	58	68
LT	160	200	250
ME	94	114	140
MR max	100	120	160
MS max	160	200	250
MT [Nm]	350	680	-
R	235	283	340
RD max f8	280	325	380
TC	320	400	500
TD f8	125	160	200
TF	380	472	588
TL	100	125	160
TM	380	485	605
UB	180	220	280
UG max	445	549	683
UM	580	735	925
UT	520	650	820
UW max	480	600	750
VD	8	8	8
VE	83	83	83
WF	110	110	110
XG	178	195	215
XV min	275	312	358
XV max	255 + stroke	273 + stroke	332 + stroke
Y	157	167	180

Ø PISTON	250	320	400
PJ	218	252	320
PK	218	252	320
XC	545	627	775
XO	580	675	830
ZB max	460	520	625
ZB1 max	505	580	685
ZJ	420	475	580
ZM	532	586	680

The dimensions of the cylinder and relative attachments are reported at the side (sect. **4**).

- Other rod diameters are available on request. Consult our technical office.

Note:

- **CH** - No. 2 holes for key
- **EE** - Oil ports and drain are threaded according to GAS standards; with counterbore dimension **D**, according to DIN 3852-2 (big size series).
On request prearrangements for ISO 6162 flange are available. Consult our technical office.
- **XV** - For L-attachment. The XV value must be included between **XV min.** and **XV max.** and must always be reported in the model code.
- **SPACERS:** For strokes longer than 1000 mm proper spacers (also for shorter strokes, on request) are designed to increase the rod and bore guide, protecting it from overloads and easy wear. Spacers can be omitted for cylinder working retracted.
The table below shows the recommended dimension depending on the stroke. For strokes longer than the ones shown in table, consult our technical office.

strokes [mm]	1001 ÷ 1500	1501 ÷ 2000	2001 ÷ 2500	2501 ÷ 3000
spacer code	2	4	6	8
length [mm]	50	100	150	200

- **Lf** - cushioning operates a progressive damping action and are adjustable with proper screws. Lf is the total cushioning length.
Lc (about 5-6 mm) is the distance, measured starting from the cylinder bottom out, where the progressive cushioning action ends (see figure).

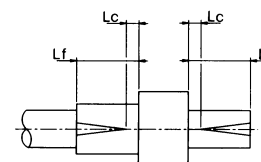

- Consult also tab. B005 and B015 to check the kinetic energy able to damp, depending on bore.
- Inductive stroke-end sensors available on request. Consult our technical office.
- MT: screw tightening torque (class 12.9)

To obtain the real total dimensions add the values on the side to the stroke and to the eventual spacers (see drawings of sect. **3** and **4**).

N.B.: - for strokes, consider the following tolerances:

- 0+1.2 mm for strokes up to 1000 mm;
- 0+2.5 mm for strokes longer than 1000 mm.

3 CH BIG SIZE BASIC CONFIGURATION - dimensions in table 2

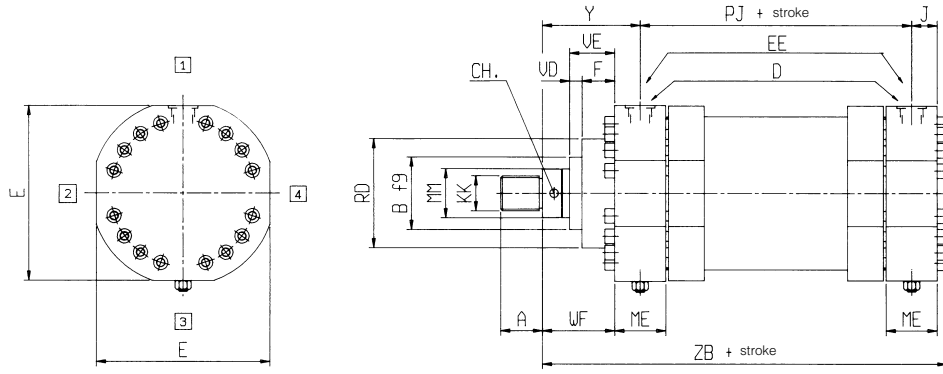

Basic configuration: X - cushioning adjustment on side 3

4 ATTACHMENTS - dimension in table 2

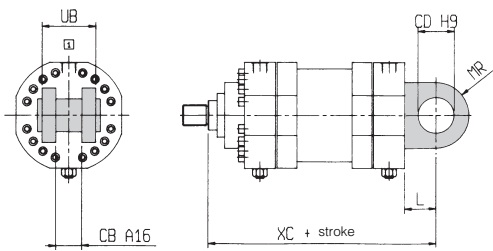

Female clevis attachment: C (ISO MP1)

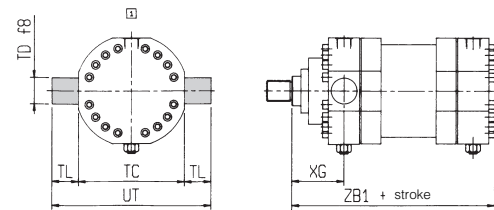

Front-body trunnion: G (ISO MT1)

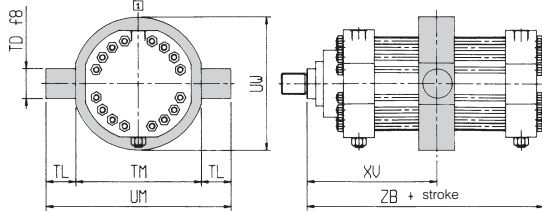

Mid-body trunnion: L (ISO MT4) tie-rod fastening

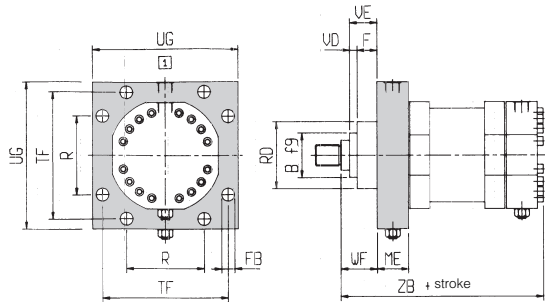

Front flange attachment: N (ISO MF5)

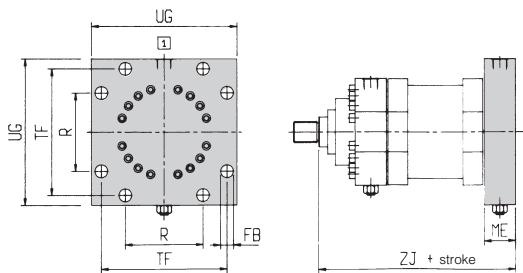

Rear flange attachment: P (ISO MF6)

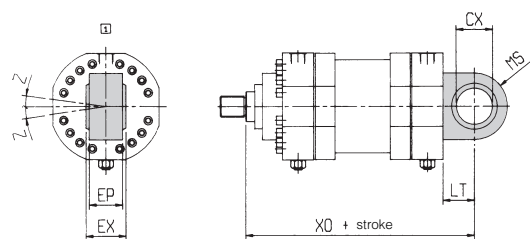

Swivel attachment with eye: S (ISO MP5)

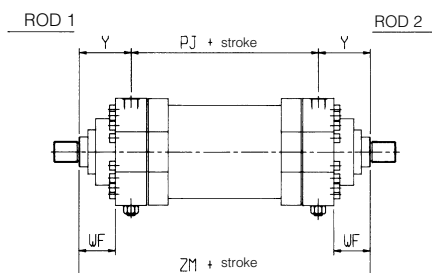

Basic execution for double-rod: X
(double-rod execution can be supplied for G-L-N attachments)

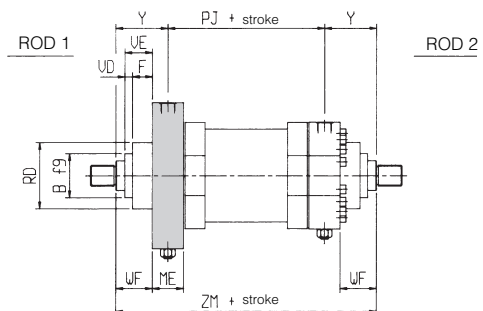

Front flange execution for double-rod: N

5 MASSES OF CH CYLINDERS BIG BORE SIZE (in kg ± 5% tolerance)

Ø Piston [mm]	Ø Rod [mm]	BASIC MASSES for single rod execution		ADDITIVE MASSES depending on attachment and options						
		for 100 mm stroke	each 100 mm more	attachment C, S	attachment G	attachment L	attachment N, P	front cushioning	rear cushioning	25 mm spacer
250	140	324	27	55	9	110	83	8,5	19	14
320	180	485	41	82	16	160	142	11	27	22
400	220	902	71	155	34	360	275	17	45	36,2

For double executions, consult our technical office.

6 CH BIG SIZE TYPICAL SECTION WITH FRONT AND REAR CUSHIONING

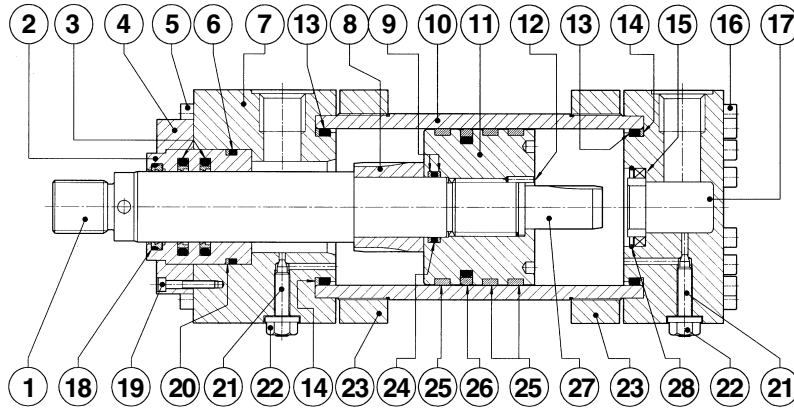

POS.	DESCRIPTION	MATERIAL	POS.	DESCRIPTION	MATERIAL	POS.	DESCRIPTION	MATERIAL
1	Rod	Chrome-plated steel	11	Piston	Steel	21	Cushion adjustment screw	Steel
2	Rod guide ring	Cast iron	12	Screw stop pin	Steel	22	Nut	Steel
3	Rod seal	Nitrile rubber + PTFE	13	"O" ring seal	Nitrile rubber	23	Counterflange	Steel
4	Flange	Steel	14	Anti-extrusion ring	PTFE	24	"O" ring seal	Nitrile rubber
5	Screw	Steel	15	Rear cushioning sleeve	Bronze	25	Low-friction seal	PTFE
6	"O" ring seal	Nitrile rubber	16	Screw TCEI	Steel (class 12.9)	26	Piston seal	Nitrile rubber + PTFE
7	Forward cylinder head	Steel	17	Rear cylinder head	Steel	27	Rear cushioning piston	Hardened steel
8	Forward cushioning piston	Hardened steel	18	Wiper	Nitrile rubber + PTFE	28	Stop ring	Steel
9	Anti-extrusion ring	PTFE	19	Screw	Steel			
10	Cylinder housing	Steel	20	Anti-extrusion ring	PTFE			

7 MODEL CODE FOR SPARE KIT OF SEALS

SP - G 8 - CH - 250 / 140/140 10

Spare kit of seals			Drawing number Always indicate the drawing number of the label
Type of seals			Rod (rods) diameter [mm] Indicate the second dimension for double rod cylinders only
Cylinder series			Piston diameter [mm]

Note: usually including the low-friction seal pos. 25.