

Pressure relief valves type ARE

direct operated, in line mounting - G 1/4" and G 1/2" threaded ports

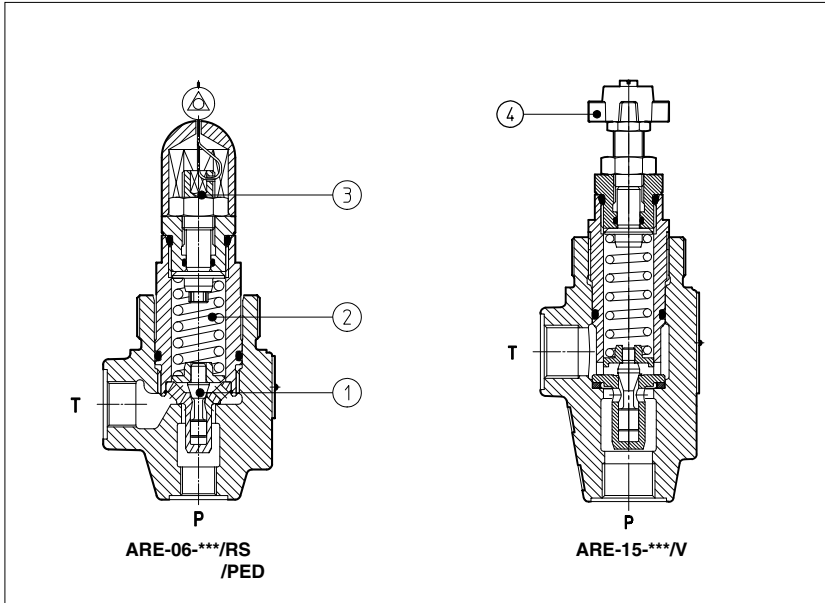

ARE are poppet type pressure relief valves, direct operated, designed to operate in oil hydraulic circuits.

The flow P→T is permitted when pressure force acting on the poppet (1) overcomes the force of the spring (2).

Regulation is operated by means of a nut (3) or optionally by means of a handwheel (4) acting on the spring. Clockwise rotation increases the pressure.

These valves are available in two sizes, with port P G 1/4" or G 1/2".

Also available in safety options with sealed regulation:

/RS conforming to Machine Directive (98/37/CE). The set pressure corresponds to the cracking pressure.

/PED conforming to PED Directive (97/23/CE). Set pressure at: ARE-06: 30 l/min; ARE-15: 50 l/min. For this version, the P, Q limits are shown in section 5.

Max flow: 100 l/min;
 Max pressure: 500 bar.

1 MODEL CODE

ARE - **06** / **350** * / * ** / *

ARE= pressure relief valve with thread connections
 Available also in cartridge execution, see table C010

Size:

06 = port P G 1/4" **15** = port P G 1/2"

Setting:

for size 06:	for size 15:
50 = 2 → 50 bar	15 = 2 → 15 bar
100 = 3 → 100 bar	50 = 3 → 50 bar
210 = 10 → 210 bar	75 = 4 → 75 bar
350 = 15 → 350 bar	150 = 8 → 150 bar
500 = 30 → 500 bar	250 = 8 → 250 bar

Synthetic fluids:
WG = water-glycol
PE = phosphate ester

Design number

Only for RS, PED options:
p = required set pressure

Options (1):

/R = reduced leakage for special applications
/RS = as /R, plus conforming to 98/37/CE
/PED = as /R, plus conforming to 97/23/CE
 not for /RS, /PED options:
/V = regulating handwheel
/VF = regulating knob
/VS = regulating knob with safety locking

(1) For handwheel and knob features and availability, see section 6 and technical table K150.

2 HYDRAULIC CHARACTERISTICS

Hydraulic symbol		
Valve model	ARE-06	ARE-15
Setting	/50 /100 /210 /350 /500 /RS /220 /270 /320 /350 /PED /100 /210 /350	/15 /50 /75 /150 /250 /RS /150 /190 /230 /PED /75 /150 /250
Pressure range [bar]	2÷50 3÷100 10÷210 15÷350 30÷500 /RS 200÷250 250÷290 290÷350 310÷370 /PED 25÷100 100÷210 210÷350	2÷15 3÷50 4÷75 8÷150 8÷250 /RS 130÷170 170÷210 210÷250 /PED 25÷75 75÷150 150÷250
Max flow [l/min]	40 /RS, /PED 60	75 /RS, /PED 100

3 MAIN CHARACTERISTICS OF PRESSURE RELIEF VALVES TYPE ARE

Assembly position	Any position
Subplate surface finishing	Roughness index $\sqrt{0.4}$, flatness ratio 0,01/100 (ISO 1101)
Ambient temperature	-20°C + 70°C
Fluid	Hydraulic oil as per DIN 51524...535; for other fluids see section 11
Recommended viscosity	15÷100 mm ² /s at 40°C (ISO VG 15÷100)
Fluid contamination class	ISO 19/16, achieved with in line filters at 25 μm value and β ₂₅ ≥ 75 (recommended)
Fluid temperature	-20°C +60°C (standard and /WG seals) -20°C +80°C (/PE seals)

4 REGULATED PRESSURE VERSUS FLOW DIAGRAMS based on mineral oil ISO VG 46 at 50°C

ARE-06

■ Min. regulated pressure

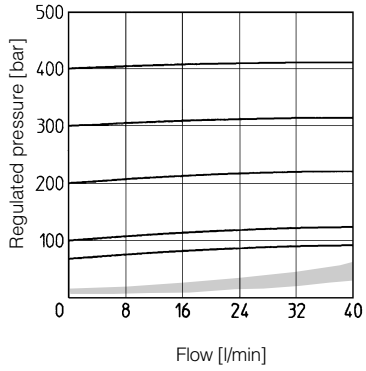

ARE-15

■ Min. regulated pressure

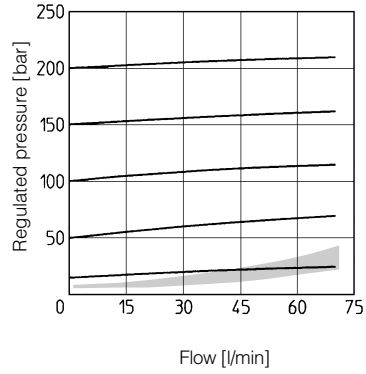

ARE-06 **/RS

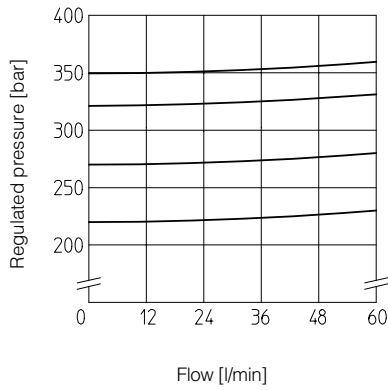

ARE-15 **/RS

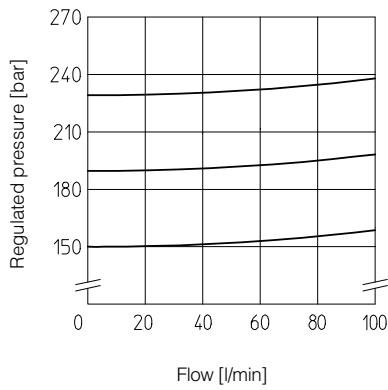

ARE-6 **/PED

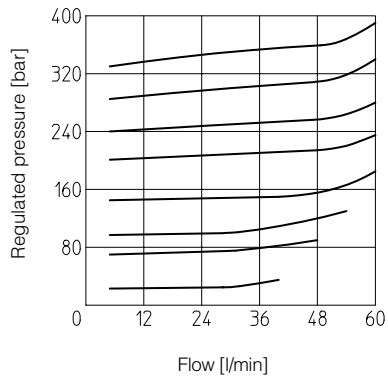

ARE-15 **/PED

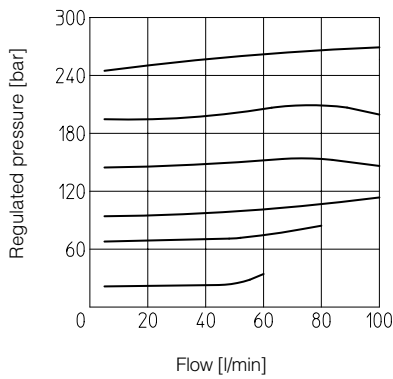

5 PERMISSIBLE RANGES (shaded area) based on mineral oil ISO VG 46 at 50°C

ARE-6 **/PED

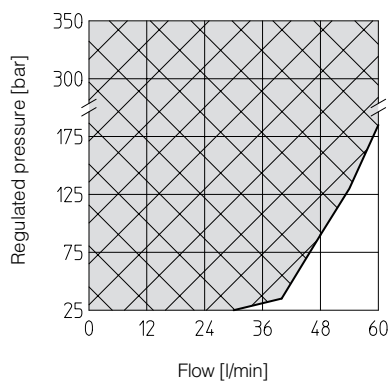

ARE-15 **/PED

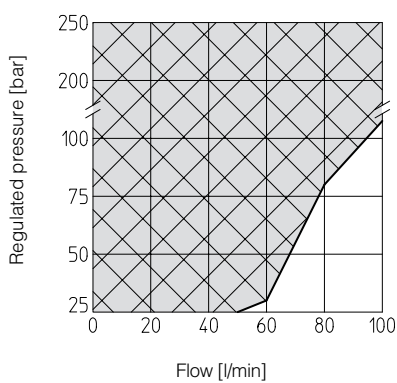

6 DIMENSIONS [mm]

ARE-06

P = INLET PORT G 1/4"
T = OUTLET PORT G 3/8"
 Locking ring for fastening the valve.
 Model code: SP-6-RE-310030

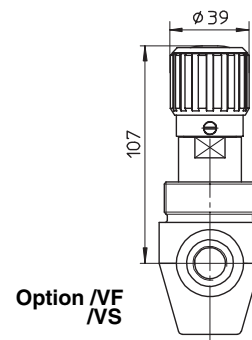
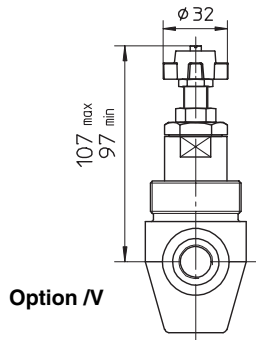
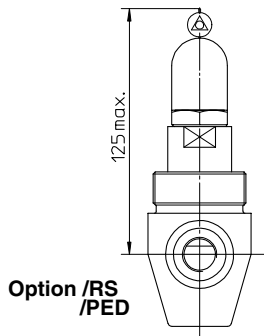
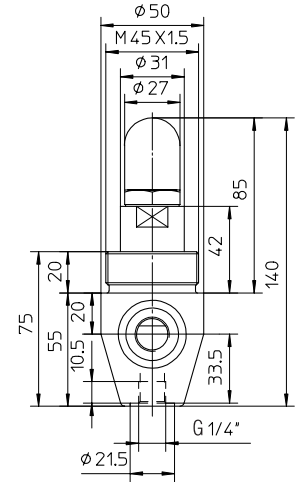
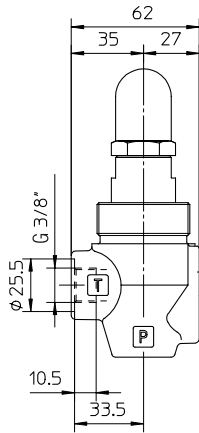
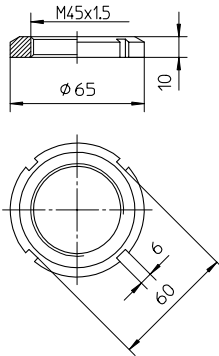

Mass: 1 Kg

ARE-15

P = INLET PORT G 1/2"
T = OUTLET PORT G 1/2"
 Locking ring for fastening the valve.
 Model code: SP-6-RE-310030

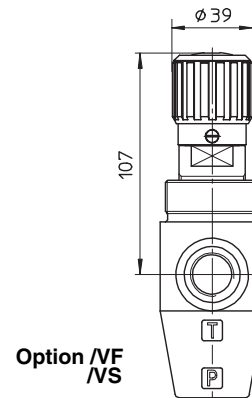
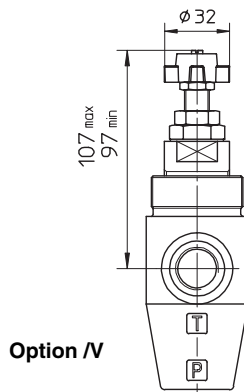
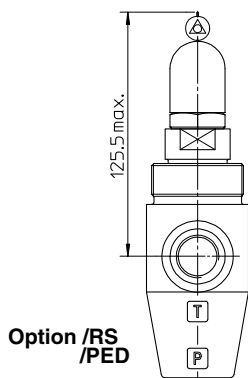
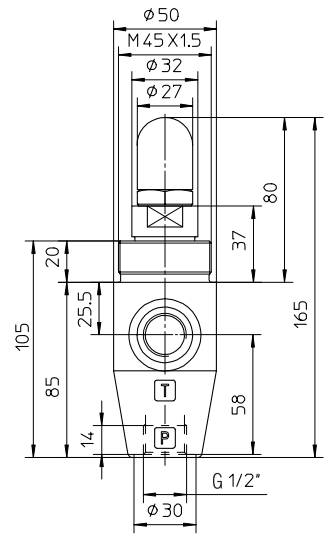
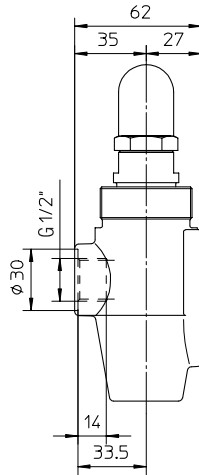
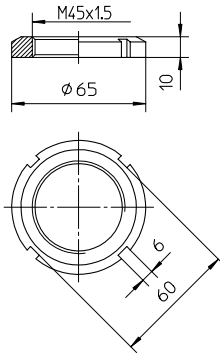

Mass: 1,3 Kg

Note
 For handwheel features, see technical table K150.