

Pressure relief valves type **AGAM**

two stage, subplate mounting - ISO 6264 size 10, 20 and 32

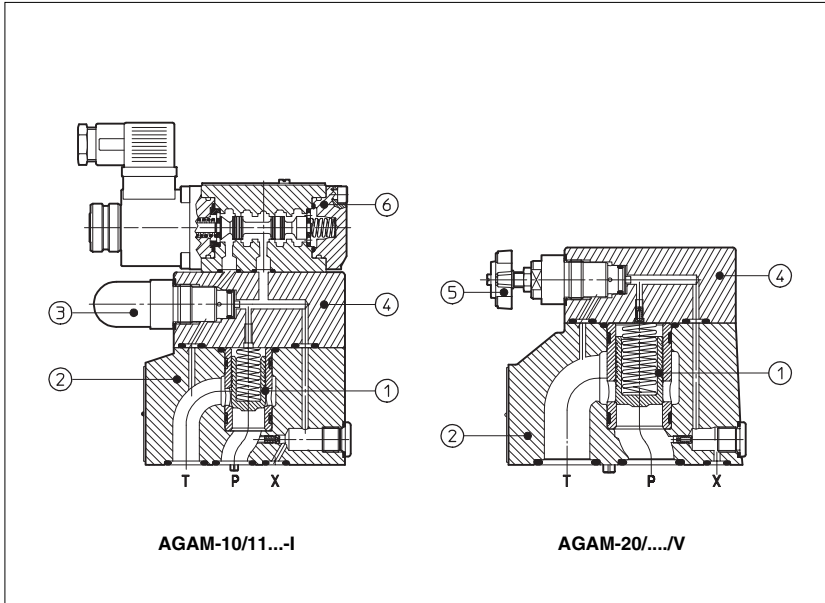

AGAM are double stage pressure relief valves with balanced poppet, designed to operate in oil hydraulic systems.

In standard versions the piloting pressure of the poppet ① of the main stage ② is regulated by means of a grub screw protected by cap ③ in the cover ④. Optional versions with setting adjustment by handwheel ⑤ instead of the grub screw are available on request. Clockwise rotation increases the pressure.

AGAM can be equipped with a venting solenoid valve ⑥ (for normally open or normally closed valves).

Mounting surface: ISO 6264 size 10, 20 and 32.
 Max flow: 200, 400 and 600 l/min respectively.
 Pressure up to 350 bar.

1 MODEL CODE

AGAM	-	20	/	2	0	/210	/100	/100	/V	-I	X	24DC	**	/*
AGAM = pressure relief valve subplate mounting				(1)	(1)			(1)		(1)	(1)	(1)		Synthetic fluids: WG = water-glycol PE = phosphate ester
Size: 10 20 32														Design number
Number of the different setting pressure values: 1 = one setting pressure 2 = two setting pressure 3 = three setting pressure														Supply voltage, see section 7: 00 = solenoid valve without coils (only for OI solenoid)
0 = venting with de-energized solenoid 1 = venting with energized solenoid 2 = without venting														X = without connector See section 6 for available connectors, to be ordered separately
Pressure range: 50 = 4÷50 bar; 100 = 6÷100 bar; 210 = 7÷210 bar; 350 = 8÷350 bar														Solenoid of pilot valve: -I = solenoid OI (DHI) for AC and DC supply
														Options (2): /V = regulating handwheel instead of a grub screw protected by cap
														Pressure range of second/third setting: 50 = 4÷50 bar; 100 = 6÷100 bar; 210 = 7÷210 bar; 350 = 8÷350 bar

(1) Only for AGAM with solenoid valve for venting and/or for the selection of the setting pressure
 (2) For handwheel features, see technical table K150

2 HYDRAULIC CHARACTERISTICS

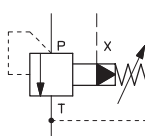
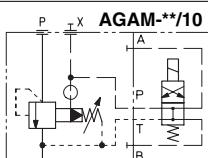
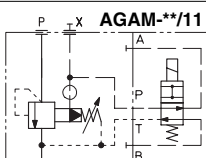
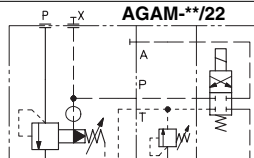
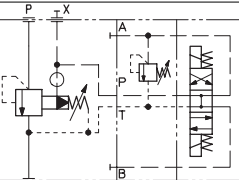
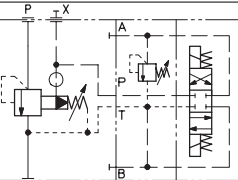
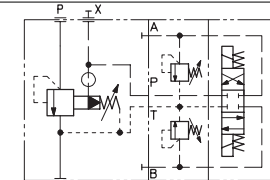
AGAM	AGAM-*/10	AGAM-*/11	AGAM-*/22
			
			
Size	10	20	32
Max flow [l/min]	200	400	600
Pressure range [bar]	4÷50; 6÷100; 7÷210; 8÷350		

3 MAIN CHARACTERISTICS OF PRESSURE CONTROL VALVES TYPE AGAM

Assembly position / location	Any position
Subplate surface finishing	Roughness index $\sqrt{0.4}$, flatness ratio 0,01/100 (ISO 1101)
Ambient temperature	-20°C to + 70°C
Fluid	Hydraulic oil as per DIN 51524 . . . 535; for other fluids see section 11
Recommended viscosity	15 ÷ 100 mm ² /s at 40°C (ISO VG 15 ÷100)
Fluid contamination class	ISO 19/16, achieved with in line filters at 25 µm value and β _{0.5} ≥ 75 (recommended)
Fluid temperature	-20°C +60°C (standard and /WG seals) -20°C +80°C (/PE seals)

3.1 Coils characteristics

Insulation class	H
Connector protection degree	IP 65
Relative duty factor	100%
Supply voltage and frequency	See electric feature 7
Supply voltage tolerance	± 10%

4 REGULATED PRESSURE VERSUS FLOW DIAGRAMS based on mineral oil ISO VG 46 at 50°C

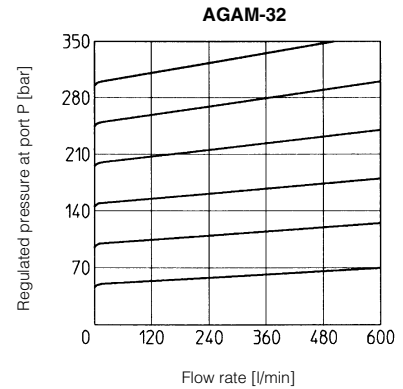
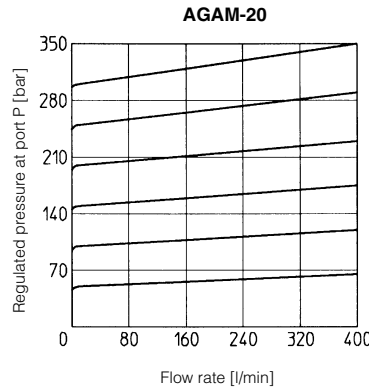
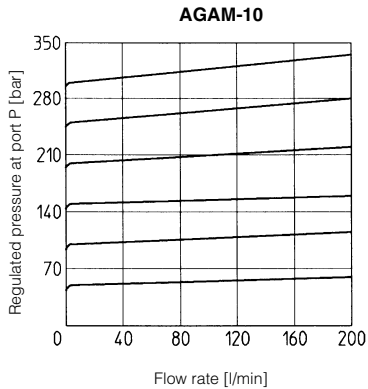

5 MINIMUM PRESSURE VERSUS FLOW DIAGRAMS based on mineral oil ISO VG 46 at 50°C

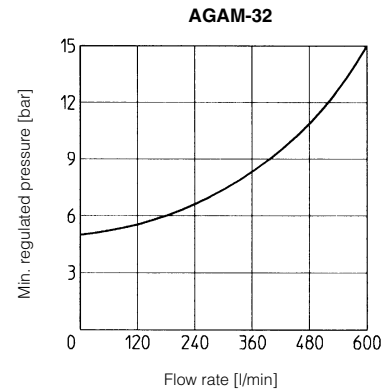
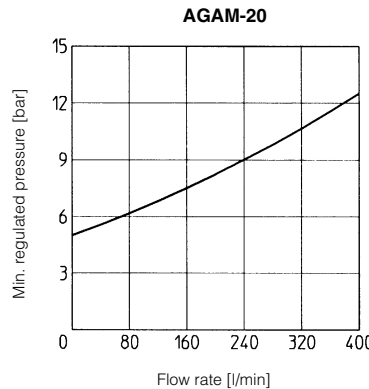
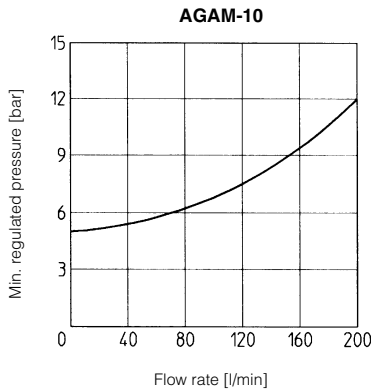

6 ELECTRIC CONNECTORS ACCORDING TO DIN 43650 FOR AGAM WITH SOLENOID VALVE

The connectors must be ordered separately

Code of connector	Function
SP-666	Connector IP-65, suitable for direct connection to electric supply source
SP-667	As SP-666 connector IP-65 but with built-in signal led, suitable for direct connection to electric supply source

For other available connectors, see tab. E010 and K500.

7 ELECTRIC FEATURES FOR AGAM WITH SOLENOID VALVE

Type of solenoid	External supply nominal voltage ± 10 % (1)		Type of connector	Power consumption (3)	Code of spare coil	Colour of coil label
OI	DIRECT CURRENT	6 DC	SP-666 or SP-667	33 W	SP-COU-6DC /80 SP-COU-12DC /80 SP-COU-24DC /80 SP-COU-48DC /80	brown green red silver
		12 DC				
24 DC						
48 DC						
ALTERNATE CURRENT	110/50 AC (2)	SP-666 or SP-667	60 VA (4)	SP-COI-110/50/60AC /80 SP-COI-120/60AC /80 SP-COI-230/50/60AC /80 SP-COI-230/60AC /80	yellow white light blue silver	
	120/60 AC					
	230/50 AC (2)					
	230/60 AC					

- (1) For other supply voltages available on request see technical table E010.
- (2) Coil can be supplied also with 60 Hz of voltage frequency: in this case the performances are reduced by 10 ÷ 15% and the power consumption is 55 VA.
- (3) Average values based on tests performed at nominal hydraulic condition and ambient/coil temperature of 20°C.
- (4) When solenoid is energized, the inrush current is approx 3 times the holding current. Inrush current values correspond to a power consumption of about 150 VA.

8 DIMENSIONS [mm]

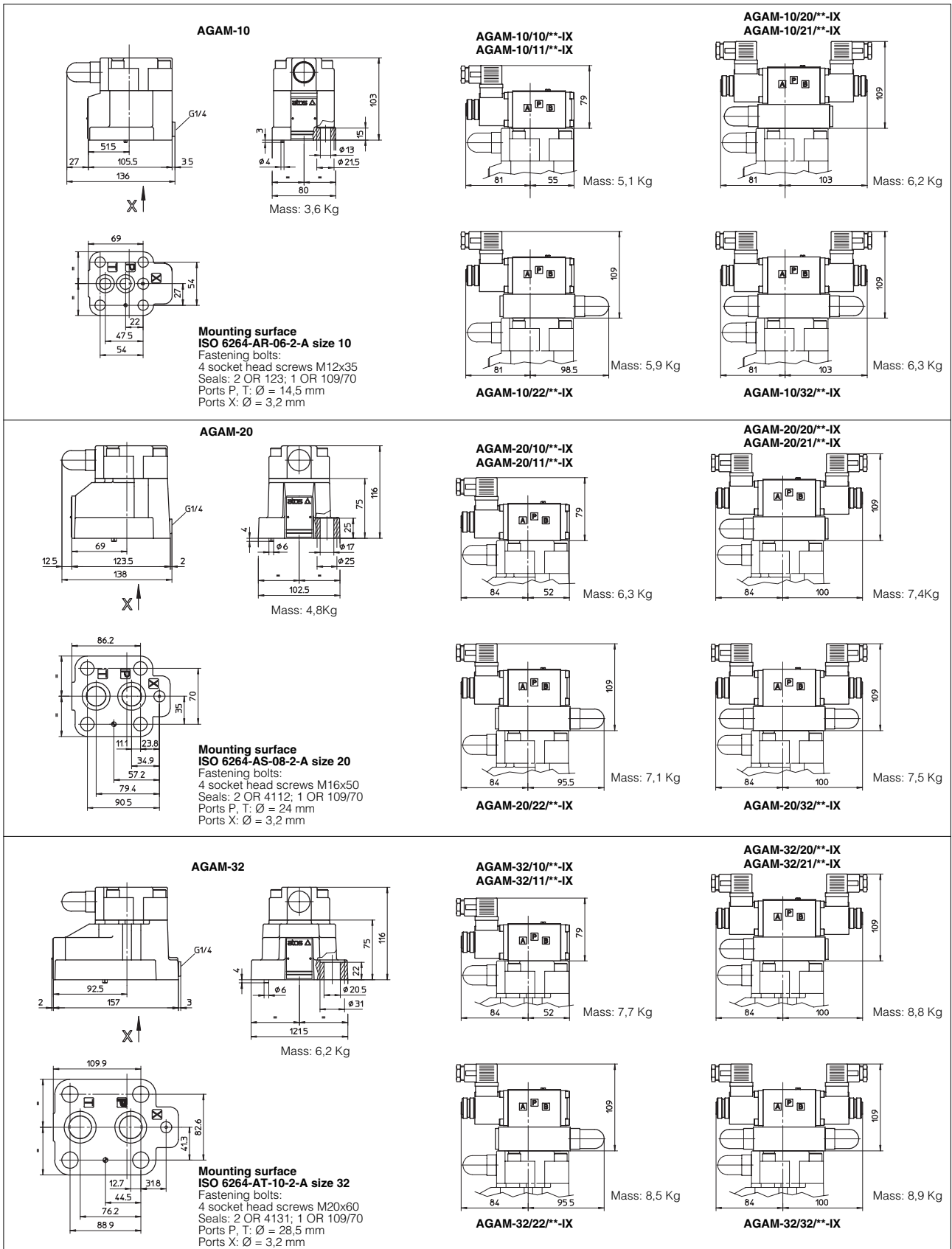

Overall dimensions refer to valves with connectors type SP-666

9 MOUNTING SUBPLATES

Valve	Subplate model	Port location	Ports			Ø Counterbore [mm]			Mass [Kg]
			P	T	X	P	T	X	
AGAM-10	BA-306	Ports P, T, X underneath;	G 1/2"	G 3/4"	G 1/4"	30	36,5	21,5	1,5
AGAM-20	BA-406		G 3/4"	G 3/4"	G 1/4"	36,5	36,5	21,5	3,5
	BA-506		G 1"	G 1"	G 1/4"	46	46	21,5	3,5
AGAM-32	BA-706		G 1 1/2"	G 1 1/2"	G 1/4"	63,5	63,5	21,5	6