

Flow restrictor valves type AQFR

in-line mounting - from G 3/8" to G 1 1/4" threaded ports

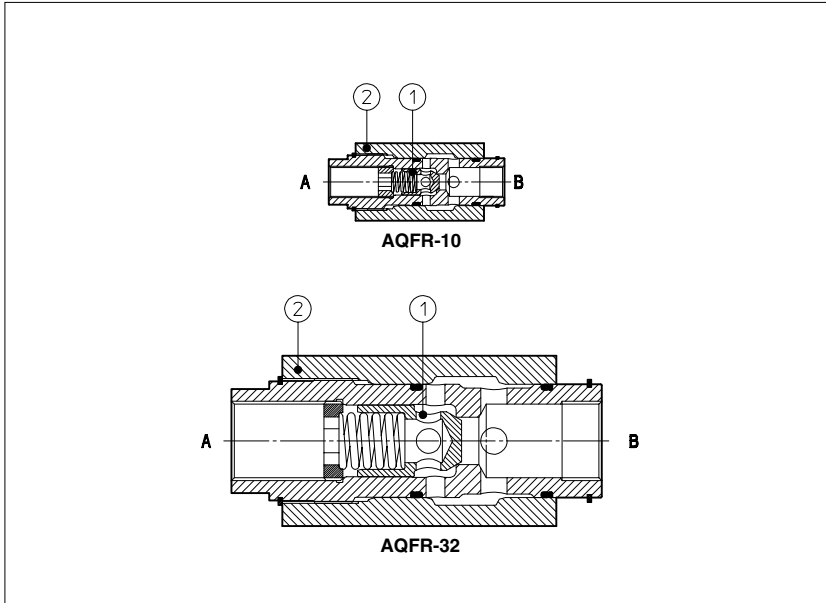

AQFR are not compensated flow throttling valves with a built-in check valve ① to allow the free flow in the opposite direction.

The flow adjustment is done by turning the external exagon ②. Clockwise rotation increases the throttling (reduced passage). The regulated flow is a function of the pressure drop existing between the inlet and outlet ports.

They are available in five sizes: from 3/8" to 1 1/4" GAS with flow up 30, 50, 80, 160, 250 l/min respectively and pressure up to 400/350 bar (depending on size).

Valves designed to operate in hydraulic systems with hydraulic mineral oil or synthetic fluid having similar lubricating characteristics.

1 MODEL CODE

AQF

R - 10

/*

Throttling valve
in-line mounting

R = with check valve for free reverse flow

Size and ports dimensions:

- 10** = G 3/8"
- 15** = G 1/2"
- 20** = G 3/4"
- 25** = G 1"
- 32** = G 1 1/4"

Synthetic fluids:
WG = water-glycol
PE = phosphate ester

Design number

2 HYDRAULIC CHARACTERISTICS

Hydraulic symbol

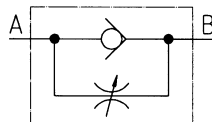

Valve model	AQFR-10	AQFR-15	AQFR-20	AQFR-25	AQFR-32
Max recommended flow [l/min]	30	50	80	160	250
Max pressure [bar]	400			350	

3 MAIN CHARACTERISTICS OF FLOW RESTRICTOR VALVES TYPE AQFR

Assembly position / location	Any position
Ambient temperature	-20°C to +70°C
Fluid	Hydraulic oil as per DIN 51525...535; for other fluids see section I
Recommended viscosity	15 ÷ 100 mm ² /sec at 40°C (ISO VG 15 ÷ 100)
Fluid contamination class	ISO 19/16, achieved with in line filters at 25 µm value and β ₂₅ ≥ 75 (recommended)
Fluid temperature	-20°C +60°C (standard and /WG seals) -20°C +80°C (/PE seals)

4 DIAGRAMS based on mineral oil ISO VG 46 at 50°C

4.1 Q/Δp diagram through the chec valve for free flow B→A with the throttle valve fully open and fully closed

- 1 = AQFR-10 fully closed
- 2 = AQFR-10 fully open
- 3 = AQFR-15 fully closed
- 4 = AQFR-15 fully open
- 5 = AQFR-20 fully closed
- 6 = AQFR-20 fully open
- 7 = AQFR-25 fully closed
- 8 = AQFR-25 fully open
- 9 = AQFR-32 fully closed
- 10 = AQFR-32 fully open

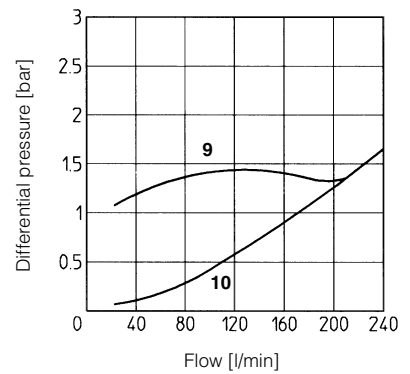
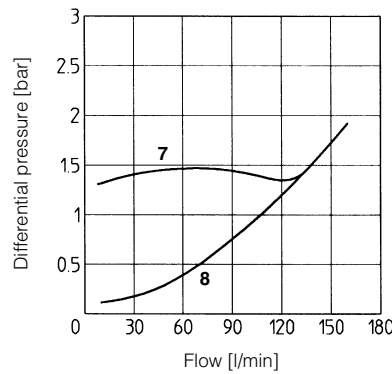
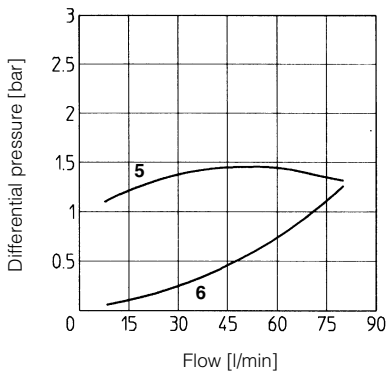
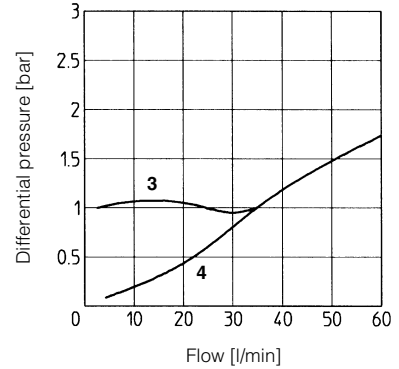
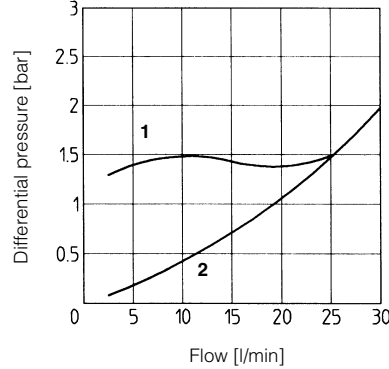

5 DIMENSIONS [mm]

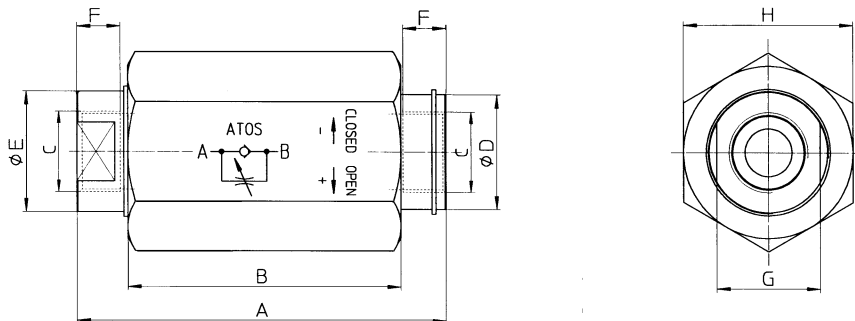

Valve model	A	B	C	ØD	ØE	F	G	H	Mass [Kg]
AQFR-10	93	68	G 3/8"	28	25	13	24	41	0,7
AQFR-15	105	78	G 1/2"	32	30	15	27	46	1
AQFR-20	127	95,5	G 3/4"	36	34	17	32	55	1,6
AQFR-25	153	112	G 1"	48	45	19	42	75	3,5
AQFR-32	196	145	G 1 1/4"	63	60	21	55	90	6,5