

Check valves type ADR

in-line mounting - from G 1/4" to G 1 1/4" threaded ports

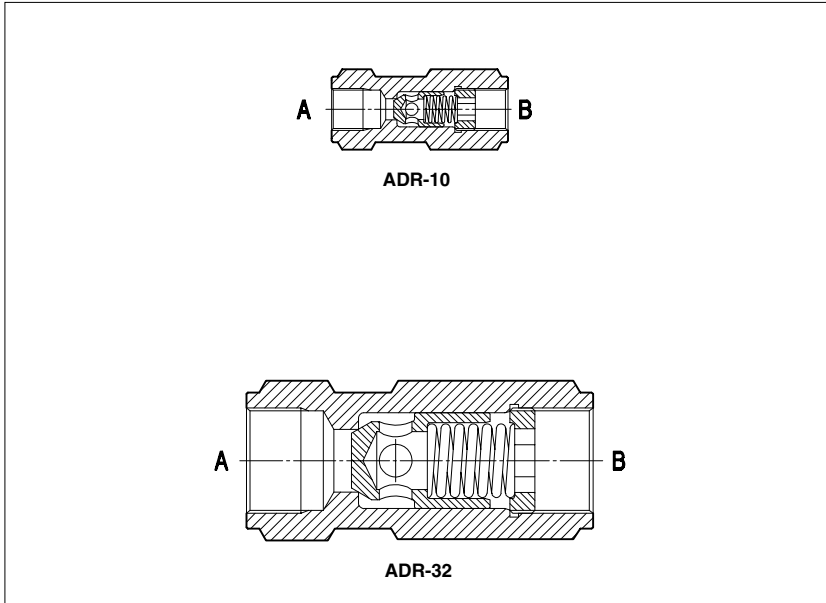

ADR are direct operated check valves for in-line mounting available with port size from 1/4" to 1 1/4" GAS.

Cartridge designed to operate in hydraulic systems with hydraulic mineral oil or synthetic fluid having similar lubricating characteristics.

Flow up to 500 l/min.
 Pressure up to 400 bar.

1 MODEL CODE	ADR	-	10	/	4	**
Check valve in-line mounting						Design number
Size/threaded connections:	06 = G 1/4" 10 = G 3/8" 15 = G 1/2" 20 = G 3/4" 25 = G 1" 32 = G 1 1/4"					Cracking pressure:
						- = 0,5 bar
						/2 = 2 bar
						/4 = 4 bar
						/8 = 8 bar

2 HYDRAULIC CHARACTERISTICS

Hydraulic symbol						
Valve model	ADR-06	ADR-10	ADR-15	ADR-20	ADR-25	ADR-32
Max recommended flow [l/min]	40	80	150	300	360	500
Max pressure [bar]	400			350		

3 MAIN CHARACTERISTICS OF CHECK VALVES TYPE ADR

Assembly position / location	Any position
Fluid	Hydraulic oil as per DIN 51524 ... 535;
Recommended viscosity	15 ÷ 100 mm ² /s at 40°C (ISO VG 15 ÷ 100)
Fluid contamination class	ISO 19/16, achieved with in line filters at 25 µm value and β ₂₅ ≥ 75 (recommended)
Fluid temperature	T ≤ 80°C
Flow direction	As shown in the symbol at section 2
Rated flow	See diagrams Q/Δp at section 4

4 FLOW VERSUS PRESSURE DROP DIAGRAMS Based on based on mineral oil ISO VG 46 at 50°C

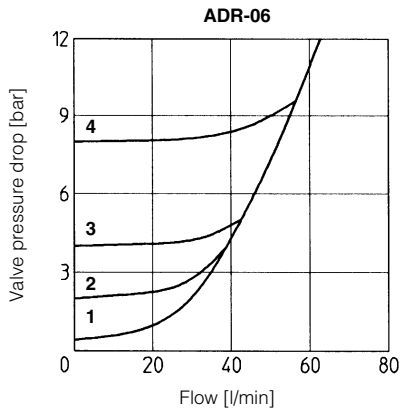

- 1 = ADR-06
- 2 = ADR-06/2
- 3 = ADR-06/4
- 4 = ADR-06/8

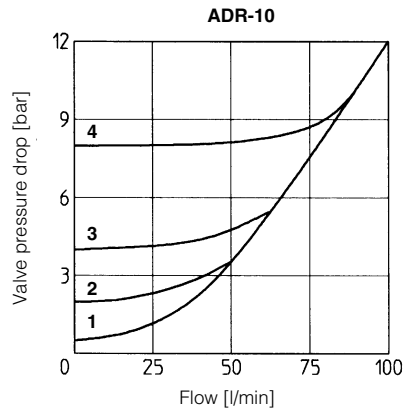

- 1 = ADR-10
- 2 = ADR-10/2
- 3 = ADR-10/4
- 4 = ADR-10/8

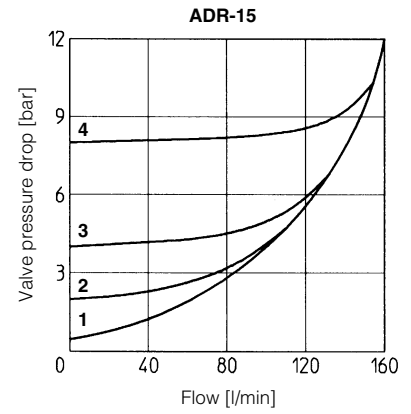

- 1 = ADR-15
- 2 = ADR-15/2
- 3 = ADR-15/4
- 4 = ADR-15/8

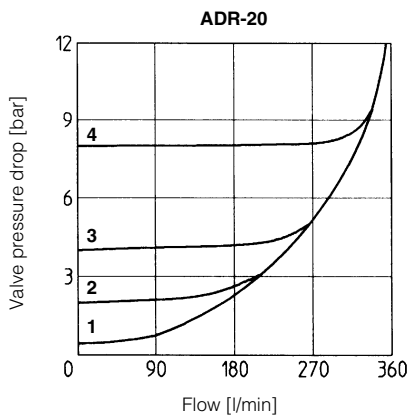

- 1 = ADR-20
- 2 = ADR-20/2
- 3 = ADR-20/4
- 4 = ADR-20/8

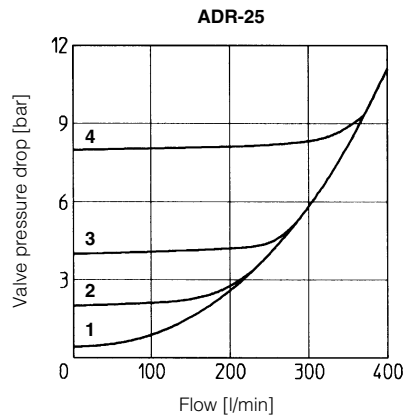

- 1 = ADR-25
- 2 = ADR-25/2
- 3 = ADR-25/4
- 4 = ADR-25/8

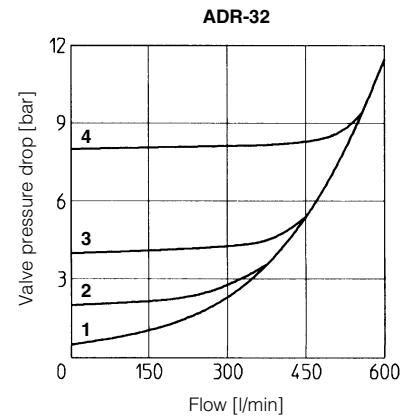

- 1 = ADR-32
- 2 = ADR-32/2
- 3 = ADR-32/4
- 4 = ADR-32/8

5 DIMENSIONS [mm]

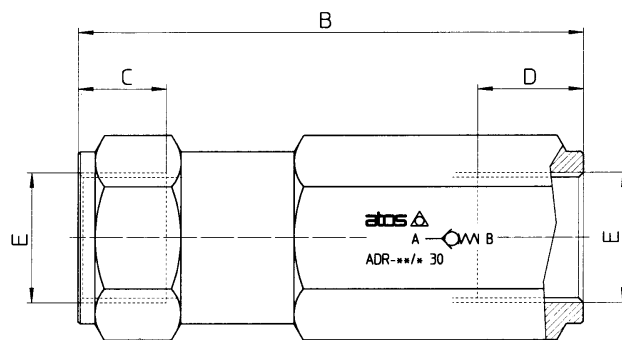
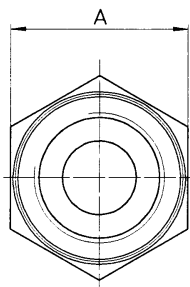

Model	A	B	C	D	E	Mass [kg]
ADR - 06	22	67	12	13	G 1/4"	0,2
ADR - 10	27	70	12	13	G 3/8"	0,4
ADR - 15	32	82,5	14	17	G 1/2"	0,6
ADR - 20	36	102,5	16	21,5	G 3/4"	0,9
ADR - 25	46	120	18	24,5	G 1"	2,1
ADR - 32	55	137,5	20	23	G 1 1/4"	2,5