

# Modular relief valves type HMP, HM, KM

ISO 4401 sizes 06 and 10

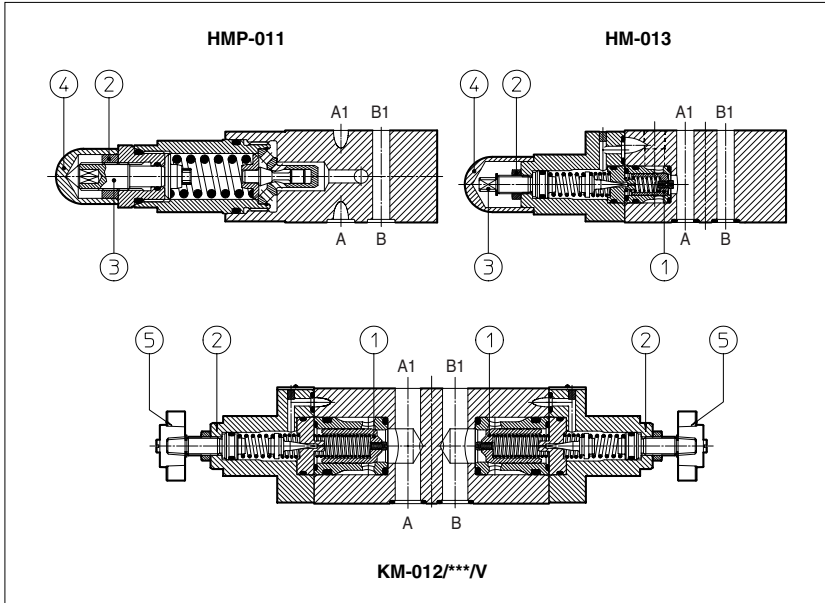

HMP are direct operated pressure relief valves.  
 HM and KM are double stage pressure relief valves with balanced poppet ①.

The pressure adjustment is operated by loosening the locking nut ② and turning the screw ③ protected by cap ④. Optional versions with setting adjustment by handwheel ⑤ instead of the screw are available on request. Clockwise rotation increases the pressure.

HMP = ISO 4401 size 06 interface; max flow: 35 l/min; max pressure up to 350 bar.

HM = ISO 4401 size 06 interface; max flow: 60 l/min; max pressure up to 350 bar.

KM = ISO 4401 size 10 interface; max flow: 120 l/min; max pressure up to 350 bar.

Valves designed to operate in hydraulic systems with hydraulic mineral oil or synthetic fluid having similar lubricating characteristics.

<b>1</b>	<b>MODEL CODE</b>	<b>HM</b>	-	<b>011</b>	/	<b>210</b>	<b>IV</b>	<b>**</b>	<b>/*</b>	
	Modular pressure relief valve size: <b>HMP</b> = 06 <b>HM</b> = 06 <b>KM</b> = 10								Synthetic fluids: <b>WG</b> = water glycol <b>PE</b> = phosphate ester	
	Configuration, see section 2							Design number		
	<b>011</b> = single, acting on port P, discharge to port T <b>012</b> = double, acting on ports A and B, discharge to port T <b>013</b> = single, acting on port A, discharge to port T <b>014</b> = single, acting on port B, discharge to port T <b>015</b> = double, acting on ports A and B, with the relieved pressure cross-discharged					Options: <b>IV</b> = setting adjustment by handwheel instead of a grub screw protected by cap Only for HMP: <b>IR</b> = reduced leakage for special applications <b>IVS</b> = with safety handwheel				
				Pressure range						
				for HMP: <b>50</b> = 2÷ 50 bar <b>100</b> = 3÷100 bar <b>210</b> = 10÷210 bar <b>350</b> = 15÷350 bar				for HM and KM: <b>50</b> = 4÷ 50 bar <b>100</b> = 5÷100 bar <b>210</b> = 5÷210 bar <b>350</b> = 5÷350 bar		

## 2 HYDRAULIC CHARACTERISTICS

Hydraulic configuration				
<b>HMP-011</b> <b>HM-011</b>	<b>HMP-012</b> <b>HM-012</b>	<b>HMP-013</b> <b>HM-013</b>	<b>HMP-014</b> <b>HM-014</b>	<b>HMP-015</b> <b>HM-015</b>
<b>KM-011</b>	<b>KM-012</b>	<b>KM-013</b>	<b>KM-014</b>	<b>KM-015</b>
Valve model		<b>HMP</b>	<b>HM</b>	<b>KM</b>
Max flow	[l/min]	35	60	120
Pressure range	[bar]	2÷50; 3÷100; 10÷210; 15÷350		4÷50; 5÷100; 5÷210; 5÷350

**3 MAIN CHARACTERISTICS OF MODULAR PRESSURE RELIEF VALVE TYPE HMP, HM, KM**

Assembly position / location	Any position
Subplate surface finishing	Roughness index $\sqrt{0.4}$ , flatness ratio 0,01/100 (ISO 1101)
Ambient temperature	-20°C to +70°
Fluid	Hydraulic oil as per DIN 51524 ... 535; for other fluids see section <b>I</b>
Recommended viscosity	15 ÷ 100 mm <sup>2</sup> /s at 40°C (ISO VG 15 ÷ 100)
Fluid contamination class	ISO 19/16, achieved with in line filters at 25 µm value and $\beta_{25} \geq 75$ (recommended)
Fluid temperature	-20°C +60°C (standard and /WG seals)    -20°C +80°C (/PE seals)

**4 REGULATED PRESSURE VERSUS FLOW DIAGRAMS** (Based on mineral oil ISO VG 46 at 50°C)

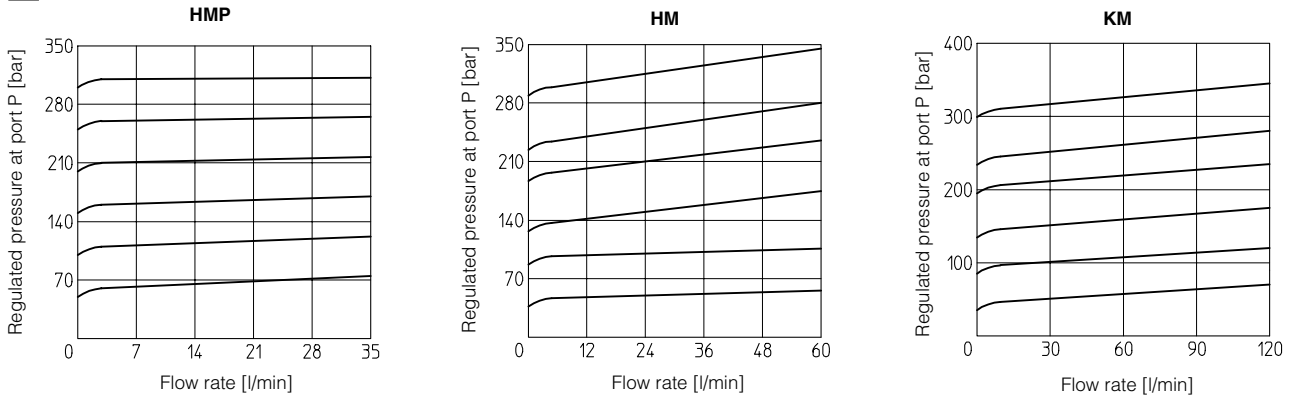

**5 MINIMUM PRESSURE VERSUS FLOW DIAGRAMS** (Based on fluid viscosity of 25 mm<sup>2</sup>/s at 40°C)

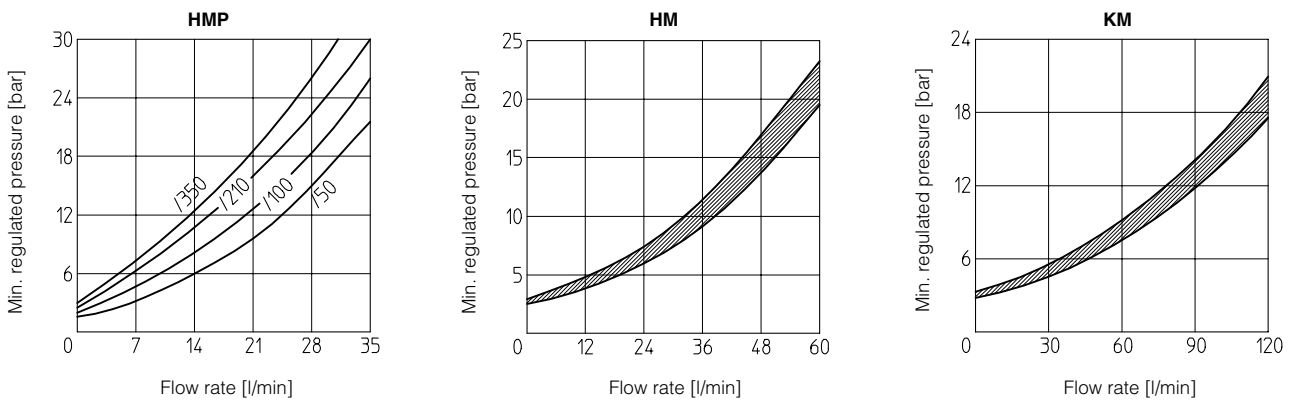

**6 INSTALLATION DIMENSIONS OF HMP VALVES [mm]**

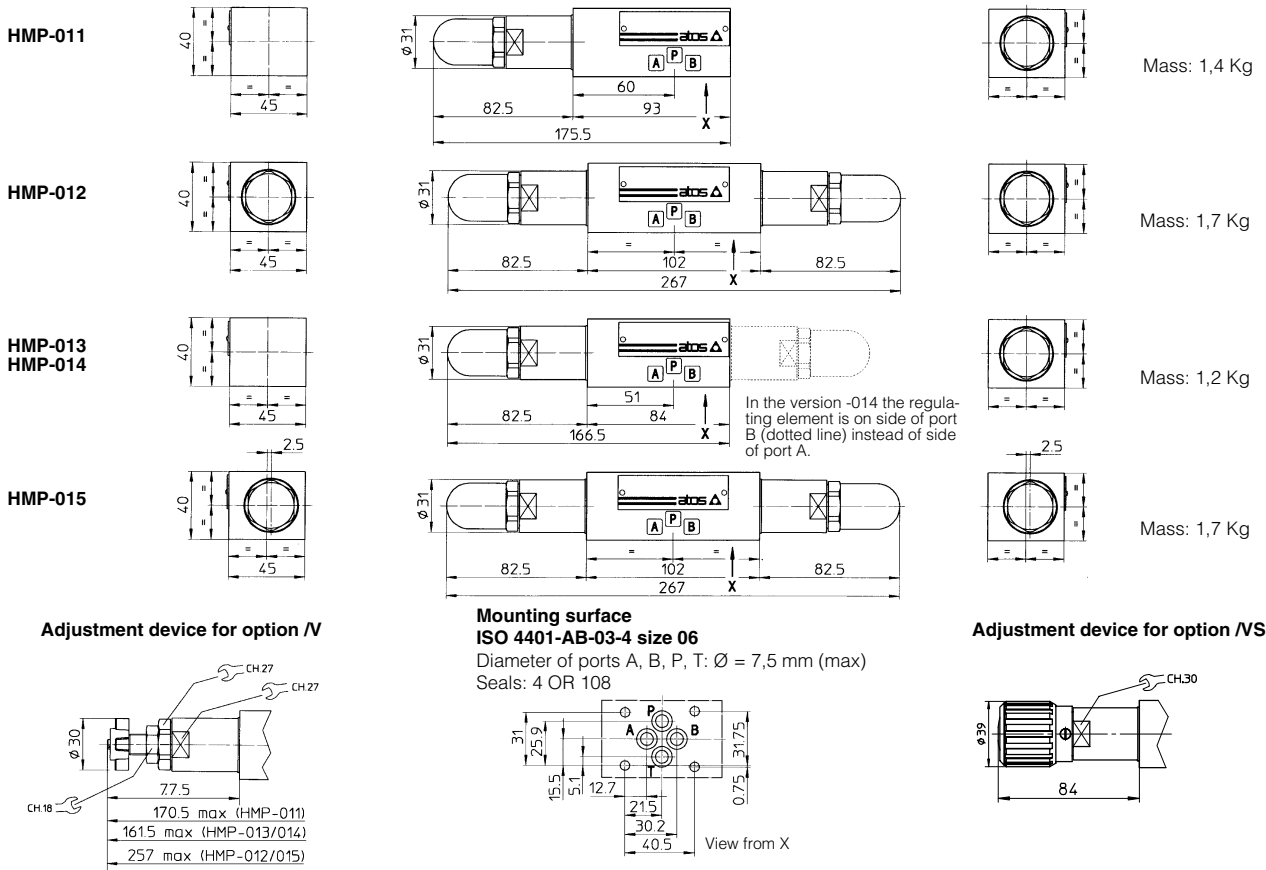

Fastening bolts: n° 4 socket head screws M5. The length depends on number and type of modular elements associated.

**7 INSTALLATION DIMENSIONS OF HM VALVES [mm]**

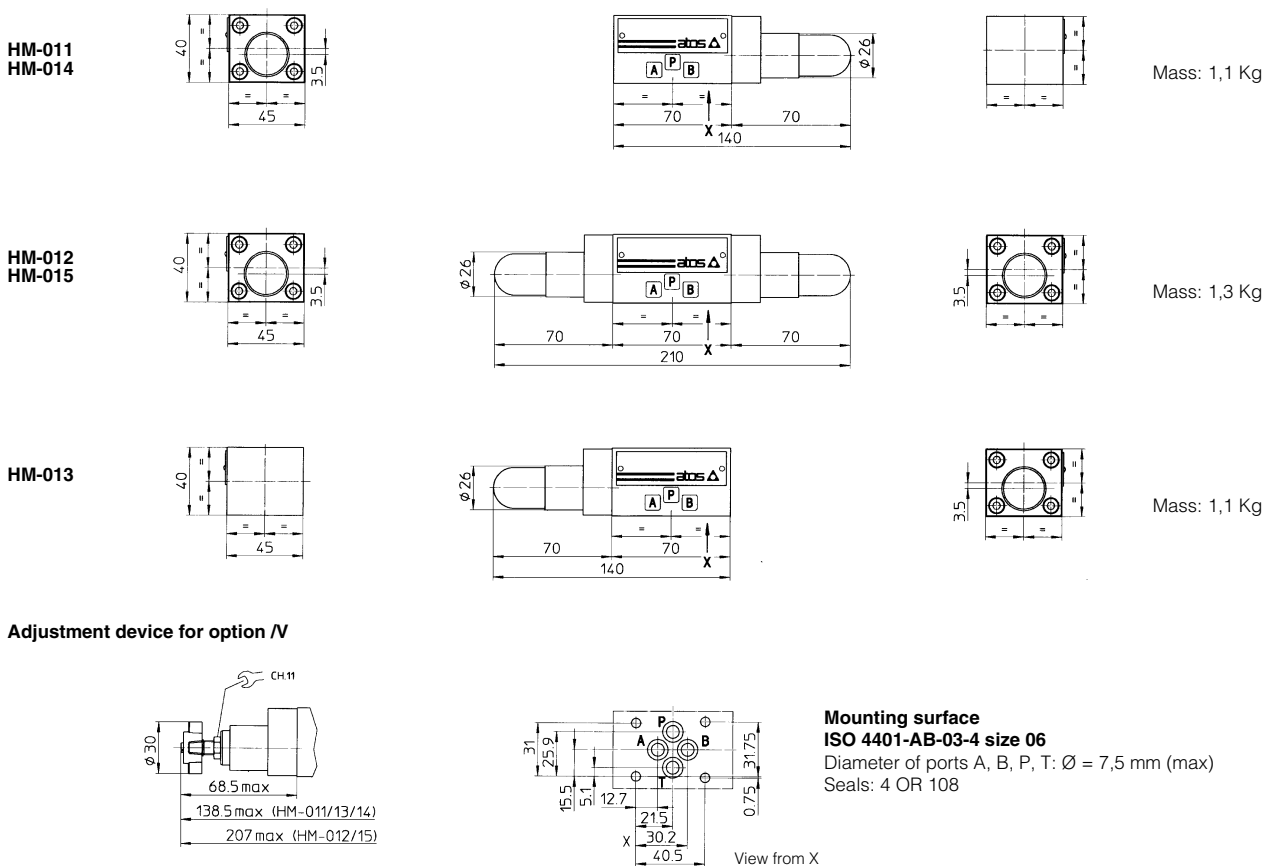

Fastening bolts: n° 4 socket head screws M5. The length depends on number and type of modular elements associated.

8 INSTALLATION DIMENSIONS OF KM VALVES [mm]

KM-011

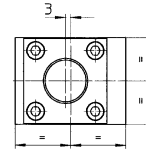
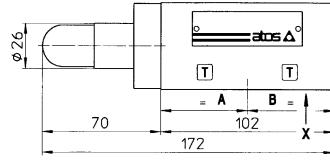
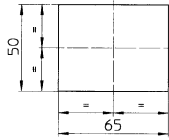

Mass: 2,5 Kg

KM-012

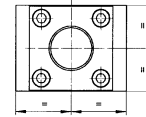
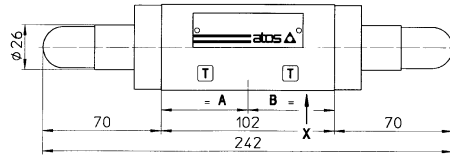
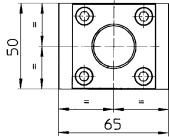

Mass: 2,8 Kg

KM-013

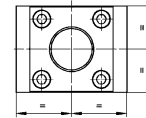
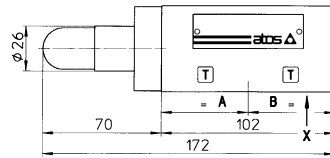
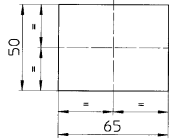

Mass: 2,5 Kg

KM-014

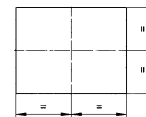
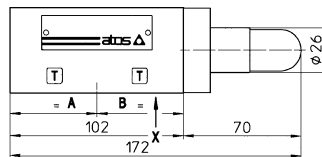
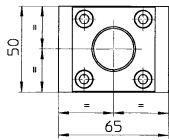

Mass: 2,5 Kg

KM-015

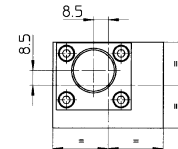
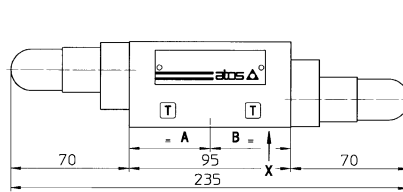
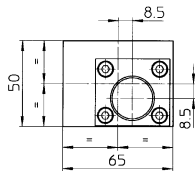

Mass: 2,5 Kg

Adjustement device for option /V

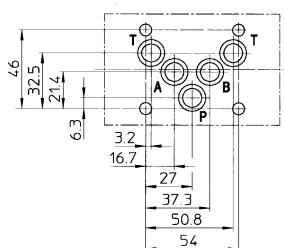
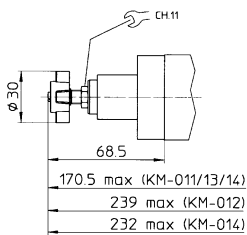

Mounting surface

ISO 4401-AC-05-4 size 10

Diameter of ports A, B, P, T:  $\varnothing = 11,2$  mm (max)  
Seals: 5 OR 2050