

# Modular sequence valves type HS-011 and KS-011

spool type, ISO 4401 size 06 and 10

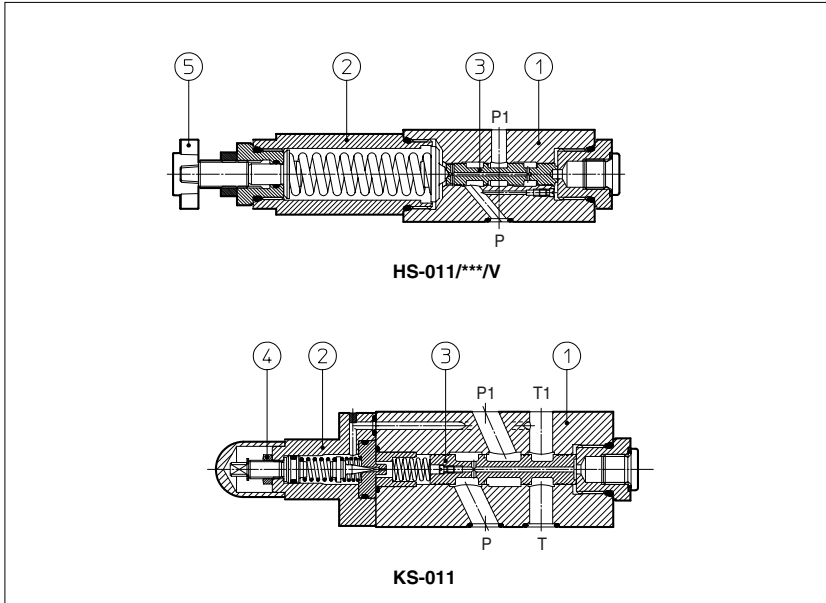

HS are direct sequence valves, spool type ③.  
 KS are double stage ① ② sequence valves, spool type ③.

Pressure adjustment is operated by loosening the locking nut ④ and turning the setting screw in the normal model.

Optional versions with a handwheel ⑤ are available on request.  
 Clockwise rotation increases the pressure.

HS = ISO 4401 size 06 interface: flow up to 40 l/min, pressure up to 210 bar.

KS = ISO 4401 size 10 interface: flow up to 80 l/min, pressure up to 210 bar.

Valves designed to operate in hydraulic systems with hydraulic mineral oil or synthetic fluid having similar lubricating characteristics.

## 1 MODEL CODE

<b>HS</b>	-	<b>011</b>	/	<b>210</b>	<b>/V</b>	<b>**</b>	<b>/*</b>
Modular sequence valve, size: <b>HS</b> = 06 <b>KS</b> = 10							Synthetic fluids: <b>WG</b> = water-glycol <b>PE</b> = phosphate ester
Configuration, see section ② <b>011</b> = single, acting on port P, drain to port T							Design number
Pressure range: for HS: <b>32</b> = 3 - 32 bar <b>100</b> = 20 - 100 bar <b>210</b> = 50 - 210 bar		for KS: <b>100</b> = 7 - 100 bar <b>210</b> = 8 - 210 bar					Options: <b>/V</b> = setting adjustment by handwheel instead of a grub screw protected by cap

## 2 HYDRAULIC CHARACTERISTICS

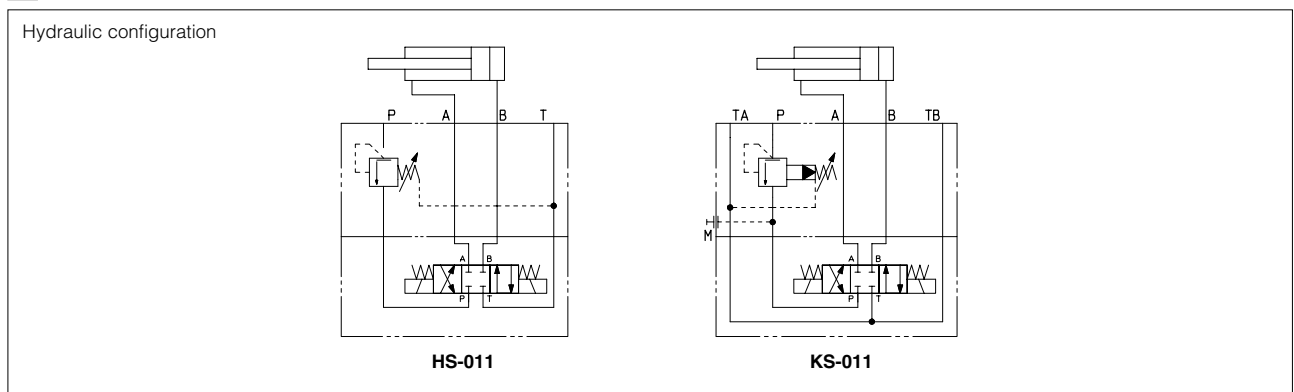

Valve model	HS-011/32	HS-011/100	HS-011/210	KS-011/100	KS-011/210
Max flow [l/min]		40		80	
Max drain [cm <sup>3</sup> /min]		50		50	
Pressure range [bar]	3 - 32	20 - 100	50 - 210	7 - 100	8 - 210
Max inlet pressure [bar]		350		315	
Max pressure on port T [bar]		160		160	

### 3 MAIN CHARACTERISTICS OF MODULAR SEQUENCE VALVES TYPE HS, KS

Assembly position	Any position
Subplate surface finishing	Roughness index $\sqrt{0.4}$ ; flatness ratio 0,01/100 (ISO 1101)
Ambient temperature	-20°C to + 70°
Fluid	Hydraulic oil as per DIN 51524...535, for other fluids see section <b>I</b>
Recommended viscosity	15 ÷ 100 mm <sup>2</sup> /s at 40°C (ISO VG 15 ÷ 100)
Fluid contamination class	ISO 19/16, achieved with in line filters at 25 µm value and $\beta_{25} \geq 75$ (recommended)
Fluid temperature	-20°C +60°C (standard and /WG seals) -20°C +80°C (/PE seals)

### 4 REGULATED PRESSURE VERSUS FLOW DIAGRAMS based on mineral oil ISO VG 46 at 50°C

1 = HS  
2 = KS

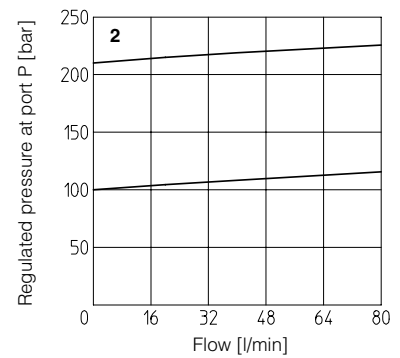
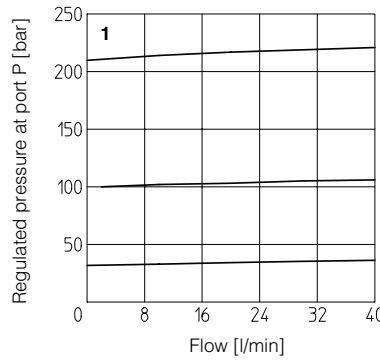

### 5 INSTALLATION DIMENSIONS [mm]

#### HS-011

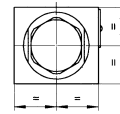
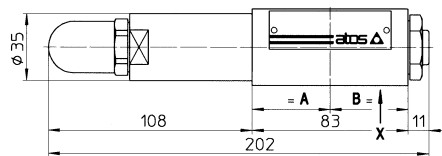
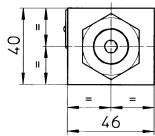

#### Adjustment device for option/V

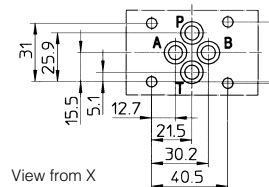
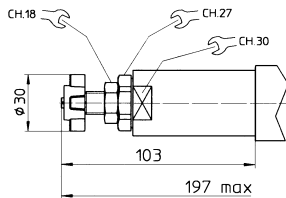

#### Mounting surface

##### ISO 4401-AB-03-4 size 06

Diameter of ports A, B, P, T:  $\varnothing = 7,5$  mm (max)  
Seals: 4 OR 108

Fastening bolts: n°4 socket head screws M5. The length depends on number and type of modular elements associated.

Mass: 2 Kg

#### KS-011

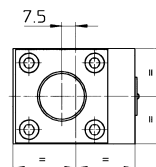
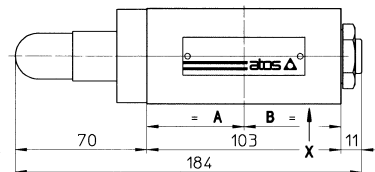
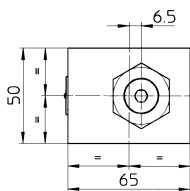

#### Adjustment device for option/V

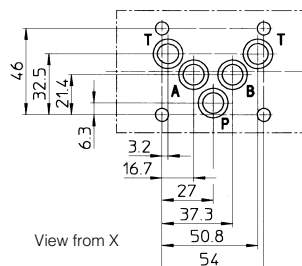
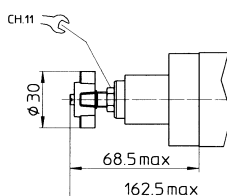

#### Mounting surface

##### ISO 4401-AC-05-4 size 10

Diameter of ports A, B, P, T:  $\varnothing = 11,2$  mm (max)  
Seals: 5 OR 2050

Fastening bolts: n°4 socket head screws M6. The length depends on number and type of modular elements associated.

Mass: 3 Kg