

Solenoid directional valves type DHI, DHU, DHO

direct operated, ISO 4401 size 06

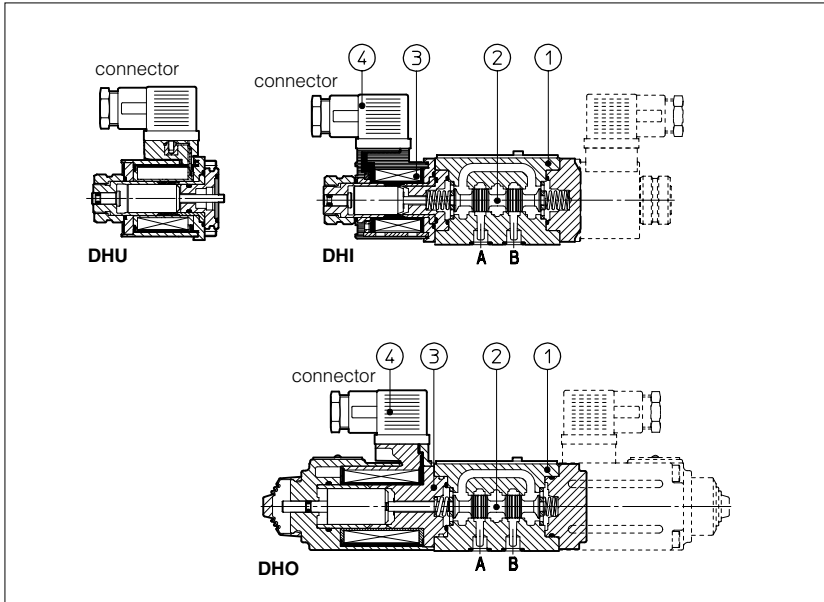

DHI, DHU and DHO are spool type, three or four way, two or three position direct operated solenoid valves designed to operate in oil hydraulic systems.

They are operated by wet and pressure sealed solenoid ③ with manual override:

- OI solenoid suitable for AC and DC supply;
- OU solenoid for DC supply with improved performance;
- OO solenoid for DC supply with high performance.

Moving parts are protected, lubricated and cushioned in oil.

Shell-moulding casting ① machined by transfer lines and then cleaned by thermal deburring.

Optimized flow paths largely cored with extrawide channels to tank for low pressure drops.

Interchangeable spools ② available in a wide variety of configurations.

DHU and DHO valves can be supplied with optional devices for control of switching times.

Standard electric/electronic connectors ④ able to satisfy the requirements of modern machines for electric interfaces characteristics.

Coils are fully encapsulated (class H). In DHI and DHU, coils are easily replaceable without aid of tools.

Rugged execution suitable for outdoor use.

Surface mounting ISO 4401 size 06.
Max flow up to 60 l/min for DHI/DHU
and up to 80 l/min for DHO.
Max pressure: 350 bar.

1 MODEL CODE

DHI - 0 63 1/2 /A - X 24 DC ** /*

Directional control valves size 06
DHI-0 = solenoid OI for AC and DC supply
DHU-0 = solenoid OU for DC supply
DHO-0 = solenoid OO for DC supply

Valve configuration, see table 2

- 61** = single solenoid, center plus external position, spring centered
 - 63** = single solenoid, 2 external positions, spring offset
 - 67** = single solenoid, center plus external position, spring offset
 - 70** = double solenoid, 2 external positions, without springs
 - 71** = double solenoid, 3 positions, spring centered
 - 75** = double solenoid, 2 external positions, with detent
 - 77** = double solenoid, center plus external position, without springs
- Other configurations are available on request.

Spool type, see table 3.

Synthetic fluids
WG = water glycol
PE = phosphate ester

Design number

External supply voltage see section 5
00 = valve without coils (only for DHI and DHU).

X = without connector
 See note 2 at section 5 for available connectors, to be ordered separately

Options, see note 1 at section 5.

2 CONFIGURATION

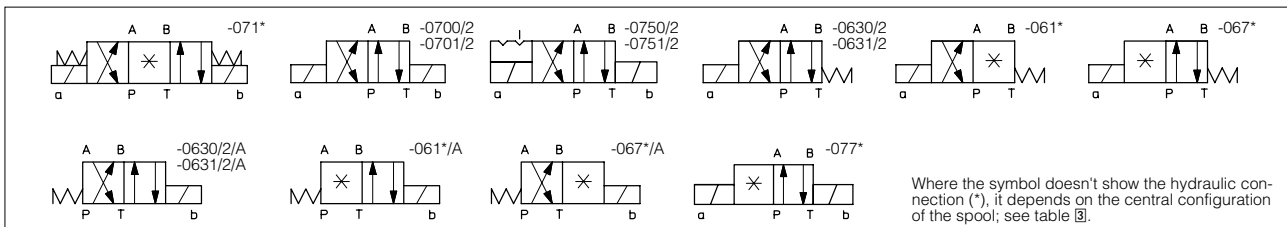

3 SPOOLS - for intermediate passages, see tab. E001.

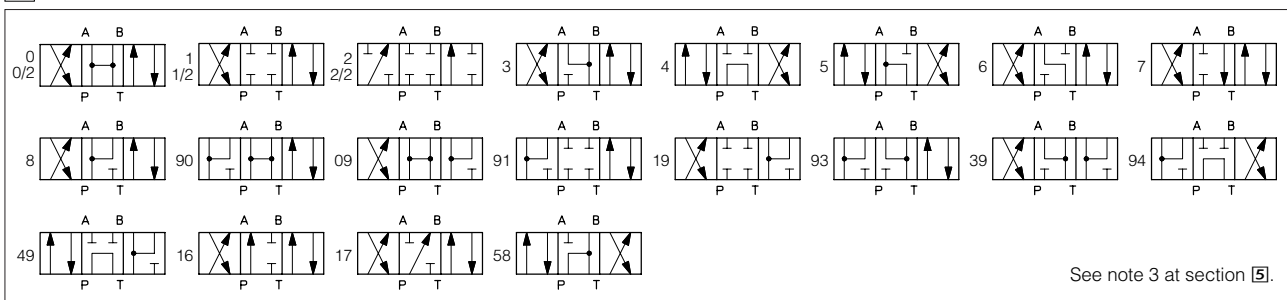

4 MAIN CHARACTERISTICS OF DHI, DHU AND DHO DIRECTIONAL VALVES

Assembly position / location	Any position for all valves except for type - 070* (without springs) that must be installed with horizontal axis if operated by impulses
Subplate surface finishing	Roughness index $\sqrt{0.4}$ flatness ratio 0,01/100 (ISO 1101)
Ambient temperature	from -20°C to +70°C
Fluid	Hydraulic oil as per DIN 51524 535; for other fluids see section 11
Recommended viscosity	15 ÷ 100 mm ² /s at 40°C (ISO VG 15 ÷ 100)
Fluid contamination class	ISO 19/16, achieved with in line filters at 25 µm value to $\beta_{25} \geq 75$ (recommended)
Fluid temperature	-20°C +60°C (standard and /WG seals) -20°C +80°C (/PE seals)
Flow direction	As shown in the symbols of tables 2 and 3
Operating pressure	Ports P,A,B: 350 bar; Port T: 120 bar for DHI; 210 bar for DHU and DHO; For versions with proximity switches (/FI/NC and /FI/NO versions) maximum counter pressure allowed on T port is 5 bar
Rated flow	See diagrams Q/Δp at section 7
Maximum flow	60 l/min for DHI and DHU; 80 l/min for DHO, see operating limits at section 8

4.1 Coils characteristics

Insulation class	H (180°C) Due to the occurring surface temperatures of the solenoid coils, the European standards EN563 and EN982 must be taken into account
Connector protection degree	IP 65
Relative duty factor	100%
Supply voltage and frequency	See electric feature 6
Supply voltage tolerance	± 10%

5 NOTES

1 Options

- A** = Solenoid mounted at side of port B (only for single solenoid valves). In standard versions, solenoid is mounted at side of port A.
WP = prolonged manual override protected by rubber cap (standard for DHO models).
L1, L2, L3, = device for switching time control, installed in the valve solenoid (only for DHU and DHO models).
 Not available for valves with connectors E-SA or E-SE. For spools 4 and 4/8 only device L3 is available.
F* = with proximity switch for monitoring spool position: see tab. E110.

2 Type of electric/electronic connector DIN 43650, to be ordered separately

- SP-666** = standard connector IP-65, suitable for direct connection to electric supply source.
SP-667 = as SP-666, but with built-in signal led.
SP-669 = with built-in rectifier bridge for supplying DC coils by alternate current (AC 110V and 230V - I_{max} 1A).
E-SA = electronic connector (only for DHI and DHU valves) which improves performances and give faster shifting times for DC solenoid supplied by AC power.
E-SE = electronic connector (only for DHI and DHU valves) which improves performances and reduces power consumption for DC solenoid supplied by DC power.
E-SR = electronic connector which permits switching of solenoid valves by a low power signal (max 20mA).
E-SD = electronic connector which eliminates electric disturbances when solenoid valves are de-energized.
 Note: disturbance suppressor devices, similar to E-SD are, standard, built in all E-SA, E-SE, E-SR.

3 Spools

- spools type 0/2, 1/2, 2/2 are only used for two position valves: single solenoid valves, type DH*-063*/2 and double solenoid valves type DH*-070*/2 and DH*-075*/2.
- spools type 0 and 3 are also available as 0/1 and 3/1 that, when in centre position, oil passage from ports to tank are restricted.
- spools type 1,4 and 5 are also available as 1/1, 4/8 and 5/1. They are properly shaped to reduce water-hammer shocks during the switching.
- spools type 1,3, 8 and 1/2 are available as 1P, 3P, 8P and 1/2P to limit valve leakage.
- Other types of spools can be supplied on request.

6 ELECTRIC FEATURES

Valve	External supply nominal voltage ± 10%	Type of connector	Power consumption (2)	Code of spare coil		Colour of coil label	
				DHI	DHU		
DHI DHU	6 DC	SP-666 or SP-667	33 W	SP-COU-6DC/80	SP-COU-6DC/80	brown	
	9 DC			SP-COU-9DC/80	SP-COU-9DC/80	light blue	
	12 DC			SP-COU-12DC/80	SP-COUR-12DC/10	green	
	14 DC			SP-COU-14DC/80	SP-COUR-14DC/10	brown	
	18 DC			SP-COU-18DC/80	SP-COU-18DC/80	blue	
	24 DC			SP-COU-24DC/80	SP-COUR-24DC/10	red	
	28 DC			SP-COU-28DC/80	SP-COUR-28DC/10	silver	
	48 DC			SP-COU-48DC/80	SP-COU-48DC/80	silver	
	110 DC			SP-COU-110DC/80	SP-COUR-110DC/10	black	
	125 DC			SP-COU-125DC/80	SP-COU-125DC/80	silver	
	220 DC			SP-COU-220DC/80	SP-COUR-220DC/10	black	
	24/50 AC			60 VA (5)	SP-COI-24/50/60AC/80 (1)	-	pink
	24/60 AC					-	white
	48/50 AC					SP-COI-110/50/60AC/80 (1)	-
	48/60 AC	SP-COI-120/60AC/80	-			white	
	110/50 AC	SP-COI-230/50/60AC/80 (1)	-			light blue	
	120/60 AC	SP-COI-230/60AC/80	-			silver	
	230/50 AC	E-SE	7 W (3)	SP-COU-6DC/80	SP-COU-6DC/80	brown	
	230/60 AC			SP-COU-12DC/80	SP-COUR-12DC/10	green	
	12 DC	E-SA (4)	67 VA 60 VA	SP-COU-24DC/80	SP-COUR-24DC/80	red	
24 DC	SP-COU-48DC/80			SP-COU-48DC/80	silver		
110/50 AC	SP-669			40 VA 35 VA	SP-COU-110RC/80	SP-COUR-110RC/10	gold
120/60 AC					SP-COU-230RC/80	SP-COUR-230RC/10	blue
230/50 AC	SP-669	40 VA 35 VA	-	-	-		
230/60 AC			-	-	-		

- (1) Coil can be supplied also with 60 Hz of voltage frequency: in this case the performances are reduced by 10 ÷ 15% and the power consumption is 55 VA.
- (2) Average values based on tests preformed at nominal hydraulic condition and ambient/coil temperature of 20°C.
- (3) In a cycle, where solenoid is energized/de-energized in 1 second (1 Hz), the average power consumption is 7 W; for longer cycles, the power consumption is lower.
When solenoid is energized the inrush current is 6 A at 12 VDC and 3 A at 24 VDC corresponding to power consumption peak of 72 W. These current peaks persist for a period shorter than 100 msec and they must be considered when electric circuit is designed.
- (4) When solenoid is energized the inrush current is 4,6A at 110 VAC and 2,3A at 230 VAC; the power consumption peak is 500 VA; these current peaks persist for a period shorter than 40 msec and they must be considered when electric circuit is designed.
- (5) When solenoid is energized, the inrush current is approx 3 times the holding current. Inrush current values correspond to a power consumption of about 150 VA.

Valve	External supply nominal voltage ± 10%	Type of connector	Power consumption (2)
DHO	12 DC	SP-666 or SP-667	32 W
	24 DC		
	110 DC	40W	
	220 DC		

Valve	External supply nominal voltage ± 10%	Type of connector	Power consumption (2)
DHO	110/50 AC	SP-669	40 W
	120/60 AC		35 W
	230/50 AC		40 W
	230/60 AC		35 W

7 Q/ΔP DIAGRAMS based on mineral oil ISO VG 46 at 50°C

Flow direction Spool type	P→A	P→B	A→T	B→T	P→T
	0	C	C	C	C
0/2, 1, 1/2	A	A	A	A	
2, 3	A	A	C	C	
2/2, 4, 5, 9*	D	D	D	D	A
6	A	A	C	A	
7	A	A	A	C	
8	C	C	B	B	

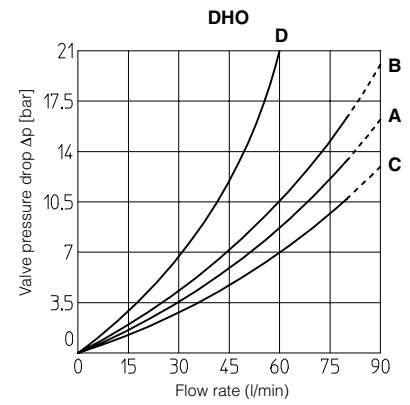
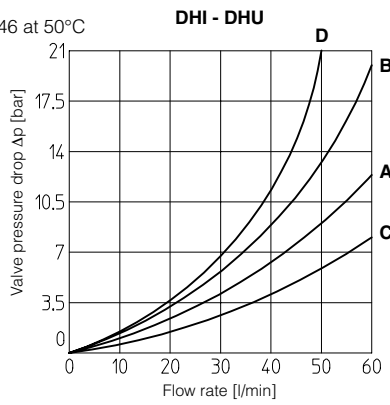

8 OPERATING LIMITS based on mineral oil ISO VG 46 at 50°C

The diagrams have been obtained with warm solenoids and power supply at lowest value ($V_{nom} - 10\%$). The curves refer to application with symmetrical flow through the valve (i.e. P→A and B→T). In case of asymmetric flow and if the valves have the devices for controlling the switching times the operating limits must be reduced.

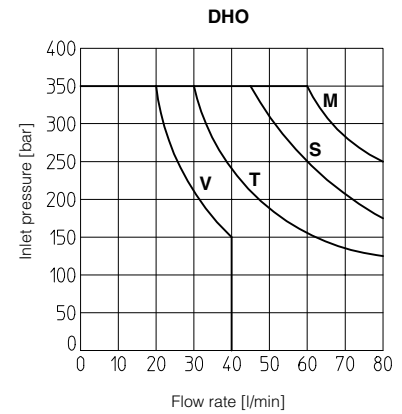
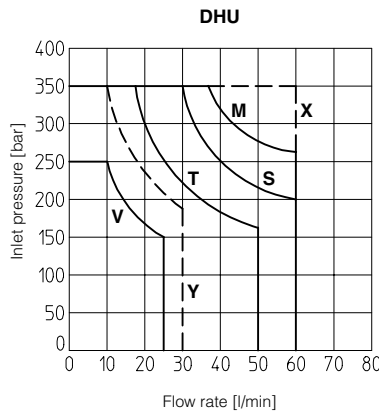
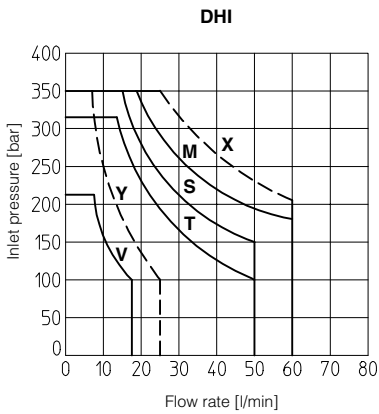

- X = Spools 0, 0/2, 1, 1/2, 3, 6, 7, 8, with E-SA or E-SE connectors.
- M = Spools 0, 1, 1/2, 8
- S = Spools 0/2, 3, 6, 7
- Y = Spools 2, 2/2, *9, 9* with E-SA or E-SE connectors
- V = Spools 2, 2/2, *9, 9*
- T = Spools 4, 5

- X = Spools 0, 0/2, 1, 1/2, 3, 6, 7, 8 with E-SA or E-SE connector.
- M = Spools 0, 1, 1/2, 8
- S = Spools 0/2, 3, 6, 7
- Y = Spools 2, 2/2, *9, 9* with E-SA or E-SE connectors.
- V = Spools 2, 2/2, *9, 9*
- T = Spools 4, 5

- M = Spools 0, 1, 1/2, 8.
- S = Spools 0/2, 3, 6, 7.
- V = Spools 2, 2/2, *9, 9*
- T = Spools 4, 5.

9 SWITCHING TIMES (average values in msec)

Valve	DHI		
	Switch-on AC	Switch-on DC	Switch-off
DHI + SP-666 SP-667	30	45	20
DHI + SP-669	45	—	80
DHI + E-SA	20	—	40
DHI + E-SD E-SR	30	45	50
DHI + E-SE	—	30	40

Valve	DHU		
	Switch-on AC	Switch-on DC	Switch-off
DHU + SP-666 SP-667	—	45	20
DHU + SP-669	45	—	80
DHU + E-SA	20	—	40
DHU + E-SD E-SR	—	45	50
DHU + E-SE	—	30	40
DHU-*L1	—	60	60
DHU-*L2	—	80	80
DHU-*L3	—	110	150

Valve	DHO		
	Switch-on AC	Switch-on DC	Switch-off
DHO + SP-666 SP-667	—	50	20
DHO + SP-669	50	—	80
DHO + E-SD E-SR	—	50	50
DHO-*L1	—	60	60
DHO-*L2	—	80	80
DHO-*L3	—	150	150

Test conditions:

- 36 l/min; 150 bar
- nominal voltage
- 2 bar of counter pressure on port T
- mineral oil: ISO VG 46 at 50°C.

The elasticity of the hydraulic circuit and the variations of the hydraulic characteristics and temperature affect the response time.

10 DIMENSIONS [mm]

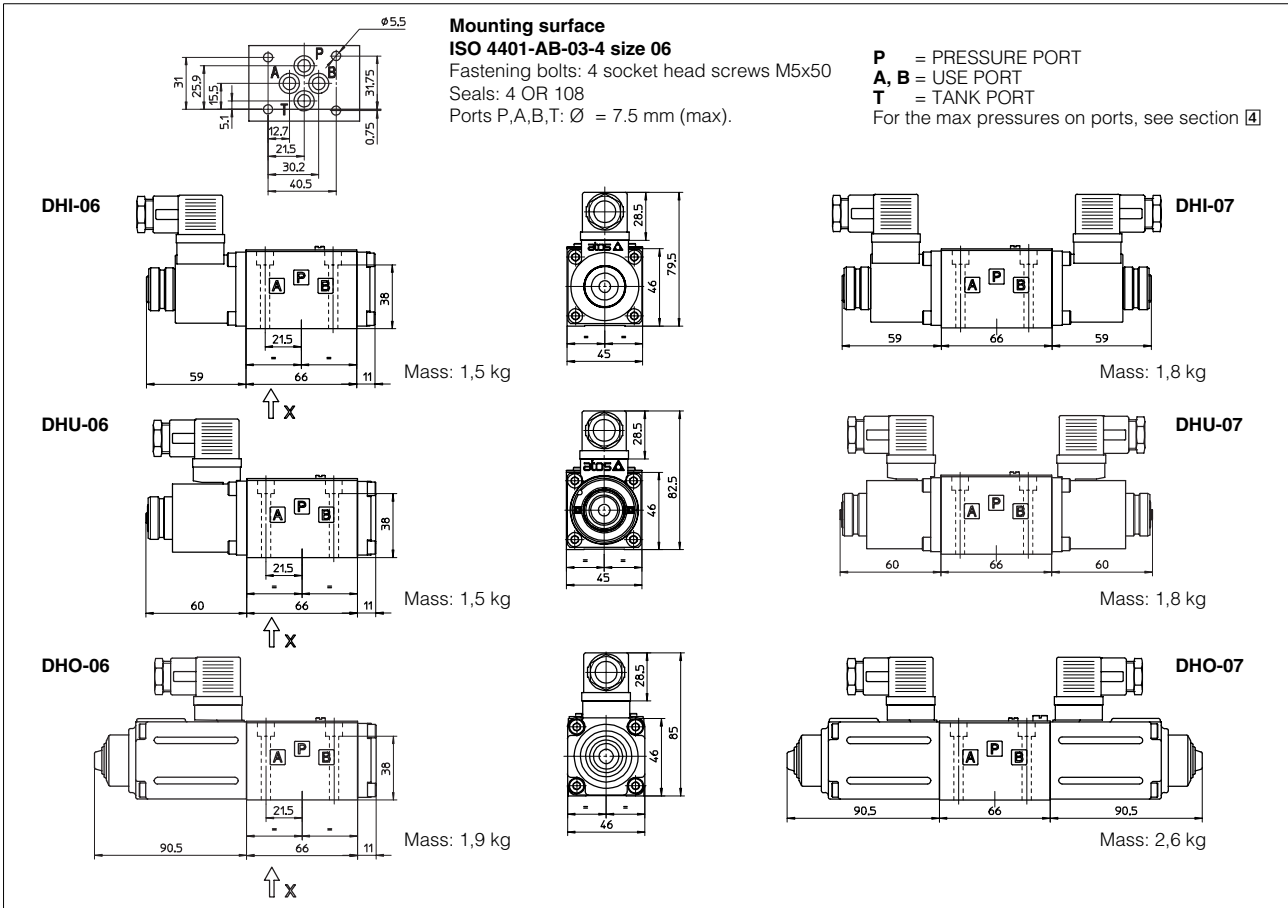

Overall dimensions refer to valves with connectors type SP-666

11 ELECTRIC/ELECTRONIC CONNECTORS ACCORDING TO DIN 43650 - The connectors must be ordered separately

<p>SP-666, SP-667 (for AC or DC supply) E-SD/DC (for DC supply)</p>	<p>SP-669 (for AC supply)</p>	<p>E-SA (for AC supply) E-SE (for DC supply) E-SR/AC (for AC supply)</p>	<p>E-SR/DC (for DC supply)</p>	<p>E-SD/AC (for AC supply)</p>			
CONNECTOR WIRING							
<p>SP-666, SP-667 1 = Positive ⊕ 2 = Negative ⊖ ⊕ = Coil ground</p>	<p>SP-669 1,2 = Supply voltage V_{ac} 3 = Coil ground</p>	<p>E-SA 1,2 = Supply voltage V_{ac} 3 = Coil ground E-SE 1 = Positive ⊕ 2 = Negative ⊖ E-SR/AC 1,2 = Supply voltage V_{ac} 3 = Coil ground 4 = Negative pilot signal V_{dc} 5 = Positive pilot signal +24V_{dc}</p>	<p>Power supply V_{dc}: RED = Positive ⊕ BLUE = Ground ⊖</p> <p>Pilot signal V_{dc}: YELLOW = Positive +24V_{dc} WHITE = Negative ⊖</p> <p>Supplied with 5 m long cable.</p>	<p>1,2 = Supply voltage V_{AC}</p>			
SUPPLY VOLTAGES							
<p>SP-666 All voltages</p>	<p>SP-667 AC or DC 24 110 230 (220)</p>	<p>E-SD-DC All DC voltages</p>	<p>E-SA 110/50 AC 120/60 AC 230/50 AC 230/60 AC</p>	<p>E-SE 12 DC 24 DC</p>	<p>E-SR-AC All voltages</p>	<p>12 DC 24 DC</p>	<p>All AC voltages</p>

12 MOUNTING SUBPLATES

Model	Ports location	GAS Ports A-B-P-T	Ø Counterbore [mm] A-B-P-T	Mass [kg]
BA-202	Ports A, B, P, T underneath;	3/8"	-	1,2
BA-204	Ports P, T underneath; ports A, B on lateral side	3/8"	25,5	1,8
BA-302	Ports A, B, P, T underneath	1/2"	30	1,8

The subplates are supplied with 4 fastening bolts M5x50. Also available are multi-station subplates and modular subplates. For further details see table K280.