

# Solenoid directional valves type DPHI, DPHU, DPHO

two stage, pilot operated, ISO 4401 size 10, 16, 25 and 32

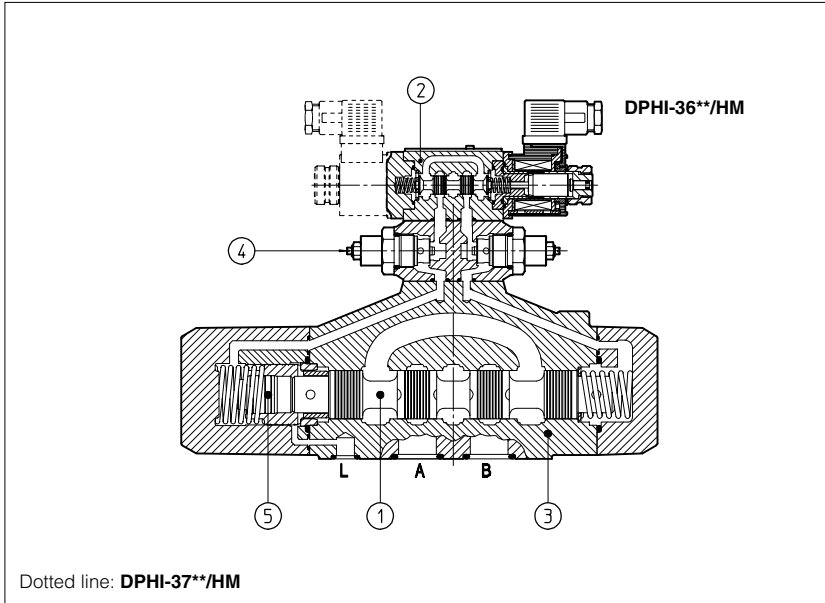

DPHI, DPHU and DPHO are spool ① type, two or three position directional piloted solenoid valves designed to operate in oil hydraulic systems.

They are actuated by a direct solenoid valve ②:

- DHI suitable for AC and DC supply;
- DHU suitable for DC supply with improved performances;
- DHO for DC supply, high performances.

Shell-moulding castings ③ machined by transfer lines and then cleaned by thermal deburring. Optimized flow paths largely cored with extrawide channels to tank for low pressure drops.

Valves can be supplied with optional devices for control of switching times ④ and with optional hydraulic centering device of main spool ⑤.

In DPHI and DPHU, coils are easily replaceable without aid of tools.

Rugged execution suitable for outdoor use.

Mounting interface: ISO 4401, size 10, 16, 25 and 32.

Max flow up to 140, 300, 650, 1000 l/min.

Pressure up to 350 bar.

## 1 MODEL CODE

<b>DPH</b>	<b>I</b>	<b>-</b>	<b>2</b>	<b>71</b>	<b>1</b>	<b>/A</b>	<b>-</b>	<b>X</b>	<b>24DC</b>	<b>**</b>	<b>/*</b>
<p>Piloted directional control valve</p> <p>Solenoid of pilot valve:  <b>I</b> = solenoid OI for AC and DC supply  <b>U</b> = solenoid OU for DC supply  <b>O</b> = solenoid OO for DC supply</p> <p>Valve size:  <b>1</b> = 10  <b>2</b> = 16  <b>3</b> = 25  <b>6</b> = 32</p> <p>Valve configuration, see section 2:  <b>61</b> = 1 single solenoid, center plus external position, spring centered  <b>63</b> = 1 single solenoid, 2 external positions, spring offset  <b>67</b> = 1 single solenoid, center plus external position, spring offset  <b>70</b> = 2 double solenoid, 2 external positions, without springs  <b>71</b> = 2 double solenoid, 3 positions, spring centered  <b>75</b> = 2 double solenoid, 2 external positions, with detent                  Other configurations are available on request</p>											
<p>Synthetic fluids:  <b>WG</b> = water-glycol  <b>PE</b> = phosphate ester</p> <p>Design number</p> <p>Supply voltage, see section 7:  <b>00</b> = solenoid valve without coils (only for DPHI and DPHU solenoids)</p> <p><b>X</b> = without connector                  See section 6 for available connectors, to be ordered separately</p> <p>Options, see note 1 at section 5</p> <p>Spool type, see section 3</p>											

## 2 CONFIGURATION

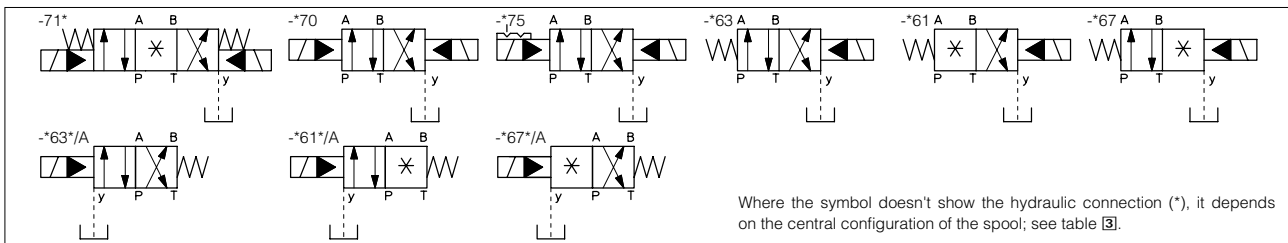

## 3 SPOOLS - for intermediate passages, see tab. E001.

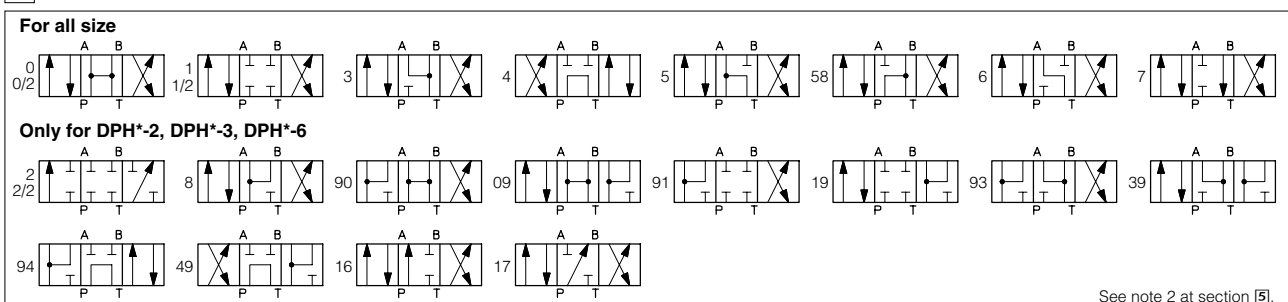

**4 MAIN CHARACTERISTICS OF SOLENOID DIRECTIONAL VALVES TYPE DPHI, DPHU, DPHO**

Installation position	Any position for all valves except for type -*70 (without springs) that must be installed with horizontal axis if operated by impulses.
Subplate surface finishing	Roughness index $\sqrt{0.4}$ flatness ratio 0,01/100 (ISO 1101)
Ambient temperature	from -20°C to +70°C
Fluid	Hydraulic oil as per DIN 51524 .... 535; for other fluids see section 11
Recommended viscosity	15 ÷ 100 mm <sup>2</sup> /s at 40°C (ISO VG 15 ÷ 100)
Fluid contamination class	ISO 19/16, achieved with in line filters at 25 µm value to $\beta_{25} \geq 75$ (recommended)
Fluid temperature	-20°C +60°C (standard and /WG seals) -20°C +80°C (/PE seals)
Flow direction	As shown in the symbols of tables 2 and 3
Operating pressure	Ports P, A, B, X: 350 bar; Port T: 250 bar (0 bar for option /D); Ports Y and L (if required): 0 bar Minimum pilot pressure for correct operation is 8 bar (10 bar with hydraulic centering device - option /M)
Rated flow	See diagrams Q/ $\Delta p$ at section 8
Maximum flow	DPH*-1: 140 l/min; DPH*-2: 300 l/min; DPH*-3: 650 l/min; DPH*-6: 1000 l/min (see rated flow at section 8 and operating limits at section 9)

**4.1 Coils characteristics**

Insulation class	H (180°C) Due to the occurring surface temperatures of the solenoid coils, the European standards EN563 and EN982 must be taken into account
Connector protection degree	IP 65
Relative duty factor	100%
Supply voltage and frequency	See electric feature 7
Supply voltage tolerance	± 10%

**5 NOTES**

**1 Options**

- /A = Solenoid mounted at side of port A of main body (only for single solenoid valves). In standard version, solenoid is mounted at side of port B.
- /D = Internal drain.
- /E = External pilot pressure.
- /FC = Microswitch for monitoring spool position (only for DPH\*-2, -3, -6).
- /F/NC = Proximity switch (two for double solenoid valves) for monitoring spool position: electric contact is closed when spool is in resting position (only for DPH\*-2, -3).
- /F/NO = Proximity switch (two for double solenoid valves) for monitoring spool position: electric contact is open when spool is in resting position (only for DPH\*-2, -3).
- /H = Adjustable chokes (meter-out to the pilot chambers of the main valve).
- /H9 = Adjustable chokes (meter-in to the pilot chambers of the main valve).
- /M = (only for three position valves and DPH\*-2, -3, -6) = Hydraulic pressure centering: For operation with pressure higher than 250 bar and high rates of flow, the use of hydraulic centering device may be recommended.
- /R = Pilot pressure generator (4 bar on port P - only for DPH\*-2, -3, -6), see section 11.
- /S = Main spool stroke adjustment (only for DPH\*-2, -3, -6).
- /WP = prolonged manual override protected by rubber cap (standard for DPHO models).
- /L1, /L2, /L3 = device for switching time control (dimension L1, L2, L3) on A and B ports of the pilot valve.

**2 Spools**

- spools type 0 and 3 are also available as 0/1 and 3/1. With them, when in centre position, oil passage from ports to tank are restricted.
- spools type 1, 4, 5, 6 and 7 are also available as 1/1, 4/8, 5/1, 6/1 and 7/1 (6/1 and 7/1 only for DPH\*-2, -3, -6) that are properly shaped to reduce water-hammer shocks during the switching (to use with option /L).
- spools type 9, 9\*, \*9, 16 and 17 are not available for DPH\*-6.
- other types of spools can be supplied on request.

**6 ELECTRONIC CONNECTORS ACCORDING TO DIN 43650** - the connectors must be ordered separately

Code of connector	Function
<b>SP-666</b>	Connector IP-65, suitable for direct connection to electric supply source
<b>SP-667</b>	As SP-666 connector IP-65 but with built-in signal led, suitable for direct connection to electric supply source..
<b>SP-669</b>	With built-in rectifier bridge for supplying DC coils by alternating current (AC 110V and 230V - I <sub>max</sub> 1A). Only for DPHO

For other available connectors, see tab. E010 and K500

**7 ELECTRIC FEATURES**

Valve	External supply nominal voltage ± 10%	Type of connector	Power consumption (2)	Code of spare coil		Colour of coil label		
				DPHI	DPHU			
DPHI DPHU	6 DC	SP-666 or SP-667	33 W	SP-COU-6DC / 80	SP-COU-6DC / 80	brown		
	9 DC			-	-	light blue		
	12 DC			SP-COU-12DC / 80	SP-COUR-12DC / 10	green		
	14 DC			SP-COU-14DC / 80	SP-COUR-14DC / 10	brown		
	18 DC			-	-	blue		
	24 DC			SP-COU-24DC / 80	SP-COUR-24DC / 10	red		
	28 DC			SP-COU-28DC / 80	SP-COUR-28DC / 10	silver		
	48 DC			SP-COU-48DC / 80	-	silver		
	110 DC			SP-COU-110DC / 80	SP-COUR-110DC / 10	gold		
	125 DC			SP-COU-125DC / 80	-	blue		
	220 DC			SP-COU-220DC / 80	SP-COUR-220DC / 10	black		
	24/50 AC			SP-669	60 VA (3)	SP-COI-24/50/60AC / 80 (1)	-	pink
	24/60 AC					SP-COI-48/50/60AC / 80 (1)	-	white
	48/50 AC					SP-COI-110/50/60AC / 80 (1)	-	yellow
48/60 AC	SP-COI-120/60AC / 80	-	white					
110/50 AC	SP-COI-230/50/60AC / 80 (1)	-	light blue					
120/60 AC	SP-COI-230/60AC / 80	-	silver					
230/50 AC	SP-669	40 VA 35 VA	SP-COU-110RC / 80	SP-COUR-110RC / 10	gold			
230/60 AC			SP-COU-230RC / 80	SP-COUR-230RC / 10	blue			
230/50 AC								
230/60 AC		35 VA						

- (1) Coil can be supplied also with 60 Hz of voltage frequency: in this case the performances are reduced by 10 ÷ 15% and the power consumption is 55 VA.
- (2) Average values based on tests performed at nominal hydraulic condition and ambient/coil temperature of 20°C.
- (3) When solenoid is energized, the inrush current is approx 3 times the holding current. Inrush current values correspond to a power consumption of about 150 VA.

Valve	External supply nominal voltage ± 10%	Type of connector	Power consumption (2)
DPHO	12 DC	SP-666 or SP-667	32 W
	24 DC		
	110 DC		40W
	220 DC		

Valve	External supply nominal voltage ± 10%	Type of connector	Power consumption (2)
DPHO	110/50 AC	SP-669	40 W
	120/60 AC		35 W
	230/50 AC		40 W
	230/60 AC		35 W

## 8 FLOW VERSUS PRESSURE DIAGRAMS

Based on mineral oil ISO VG 46 at 50°C

Flow direction Spool type	P→A	P→B	A→T	B→T	P→T
	0, 0/2	C	C	B	B
1, 1/2, 3	B	B	A	A	-
4	E	E	D	D	C
6	C	C	A	C	-
7	C	C	C	A	-
5	D	D	C	C	-

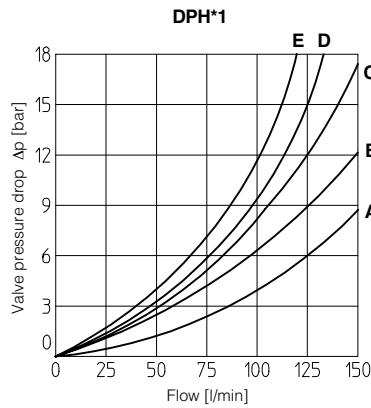

## 9 OPERATING LIMITS

The max recommended flow rates - l/min - for a correct operation are shown in the tables below for some typical spools and inlet pressure. For higher values the use of the hydraulic centering device is recommended.

Spool	Inlet pressure			
	70	140	210	350
0, 1, 3, 6, 7	140	140	140	130
4, 4/8	140	140	120	90
5, 5/8	140	140	130	110
0/1, 0/2	140	140	130	120

Flow direction Spool type	P→A	P→B	A→T	B→T	P→T
	4, 4/8	-	-	-	-
Other	2	2	2	2	-

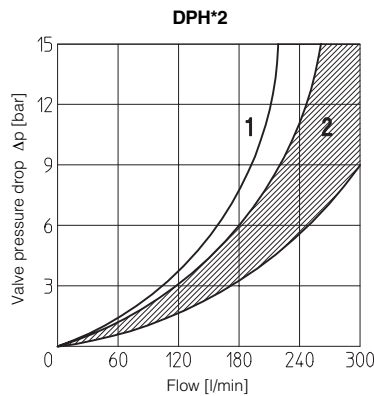

Spool	Inlet pressure			
	70	140	210	350
0, 1, 3, 6, 7, 8	300	300	300	250
2, 4, 4/8	300	300	240	140
5	260	220	180	100
0/1	300	250	210	180
*9, 9*	300	300	270	200

Flow direction Spool type	P→A	P→B	A→T	B→T	P→T
	4, 4/8	-	-	-	-
Other	2	2	2	2	-

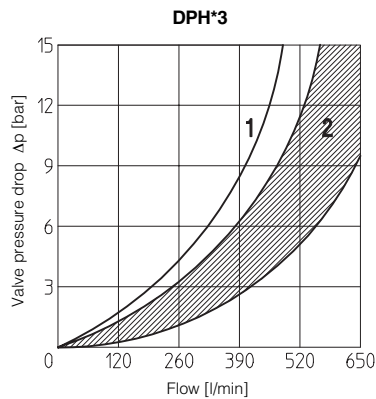

Spool	Inlet pressure			
	70	140	210	350
1, 6, 7, 8	650	650	650	600
2, 4, 4/8	500	500	450	400
5, 0/1	600	520	400	300
0, 3	650	650	600	540
*9, 9*	500	500	500	450

Flow direction Spool type	P→A	P→B	A→T	B→T	P→T
	4, 4/8	-	-	-	-
Other	2	2	2	2	-

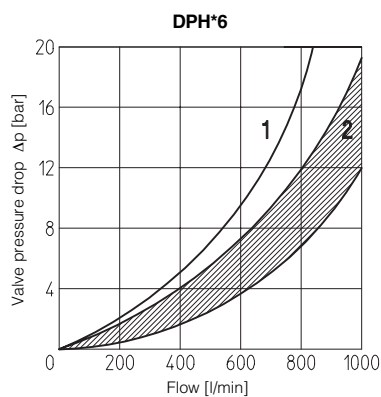

Spool	Inlet pressure			
	70	140	210	350
1, 6, 7, 8	1000	950	850	700
0	950	900	800	650
4, 4/8, 5	850	800	700	450
0/1	950	850	650	450

**10 SWITCHING TIMES** (average values in m sec)

**DPH\*-1**

Configuration		Piloting pressure							
		70 bar		140 bar		210 bar		250 bar	
		DPHI	DPHI DPHU DPHO	DPHI	DPHI DPHU DPHO	DPHI	DPHI DPHU DPHO	DPHI	DPHI DPHU DPHO
		Alternating current	Direct current	Alternating current	Direct current	Alternating current	Direct current	Alternating current	Direct current
71, 61, 67, 61*/A, 67*/A	Switch ON	35	50	30	45	25	40	20	35
	Switch OFF	50							
63, 63*/A	Switch ON	50	75	40	65	35	55	30	50
	Switch OFF	80							

**DPH\*-2**

Configuration		Piloting pressure							
		70 bar		140 bar		210 bar		250 bar	
		DPHI	DPHI DPHU DPHO	DPHI	DPHI DPHU DPHO	DPHI	DPHI DPHU DPHO	DPHI	DPHI DPHU DPHO
		Alternating current	Direct current	Alternating current	Direct current	Alternating current	Direct current	Alternating current	Direct current
71, 61, 67, 61*/A, 67*/A	Switch ON	40	55	30	50	25	45	20	40
	Switch OFF	60							
63, 63*/A	Switch ON	55	80	45	70	40	60	35	55
	Switch OFF	95							

**DPH\*-3**

Configuration		Piloting pressure							
		70 bar		140 bar		210 bar		250 bar	
		DPHI	DPHI DPHU DPHO	DPHI	DPHI DPHU DPHO	DPHI	DPHI DPHU DPHO	DPHI	DPHI DPHU DPHO
		Alternating current	Direct current	Alternating current	Direct current	Alternating current	Direct current	Alternating current	Direct current
71, 61, 67, 61*/A, 67*/A	Switch ON	60	80	45	60	35	50	30	45
	Switch OFF	80							
63, 63*/A	Switch ON	95	115	75	95	65	75	50	65
	Switch OFF	130							

**DPH\*-6**

Configuration		Piloting pressure							
		70 bar		140 bar		210 bar		250 bar	
		DPHI	DPHI DPHU DPHO	DPHI	DPHI DPHU DPHO	DPHI	DPHI DPHU DPHO	DPHI	DPHI DPHU DPHO
		Alternating current	Direct current	Alternating current	Direct current	Alternating current	Direct current	Alternating current	Direct current
71, 61, 67, 61*/A, 67*/A	Switch ON	70	95	55	70	45	60	40	55
	Switch OFF	150							
63, 63*/A	Switch ON	115	145	95	110	80	100	70	90
	Switch OFF	280							

**Notes:**

- For configuration 70 and 75, times of switching ON and switching OFF are the same: this value is equal to time of switch ON of configuration 63.
- TEST CONDITIONS
  - Nominal voltage supply DC (direct) and AC (alternating) with connector type SP-666. The use of other connectors can affect the switching time;
  - 2 bar of counter pressure on port T;
  - mineral oil: ISO VG 46 at 50°C
- The response time is affected by elasticity of the hydraulic circuit, by variation of hydraulic characteristics and temperature.

**11 PILOT PRESSURE GENERATOR (OPTION /R)**

The device /R generates an additional pressure drop, in order to ensure the minimum pilot pressure, for correct operation of the valves with internal pilot and fitted with spools type 0, 0/1, 4, 4/8, and 5. The device /R has to be fitted when the pressure drop in the valve, verified on flow versus pressure diagrams, is lower than the minimum pilot pressure value.

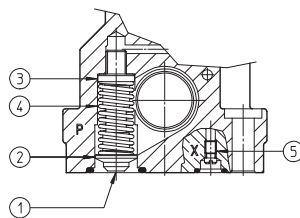

- ① Flapper-guide
- ② Flapper
- ③ Spring stop-washer

- ④ Spring  
for DPH\*-2: MO-447  
for DPH\*-3: MO-472  
for DPH\*-6: MO-448

- ⑤ Plug  
for DPH\*-2: SP-X500  
for DPH\*-3: SP-X300  
for DPH\*-6: SP-X300

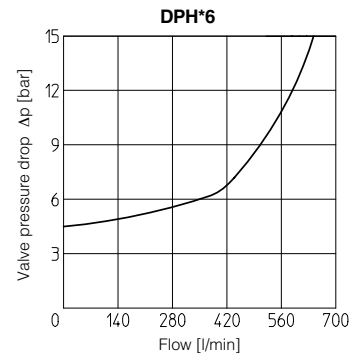
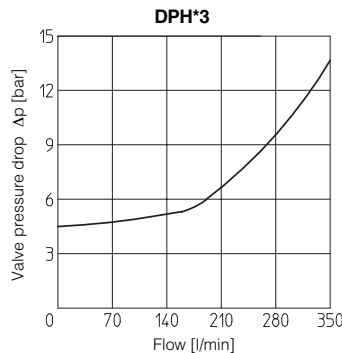
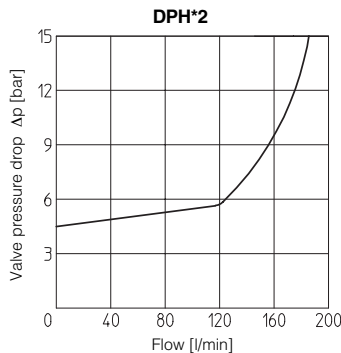

**12 ORIFICE LOCATION FOR PILOT/DRAIN CHANNELS**

Depending on the position of internal plugs, different pilot/drain configurations can be obtained as shown below. To modify the pilot/drain configuration proper plugs must only be interchanged. Standard valves have internal pilot and external drain

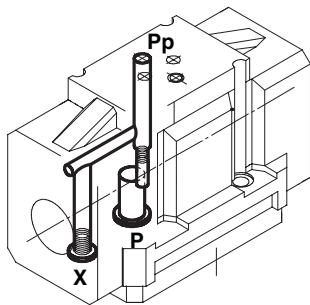
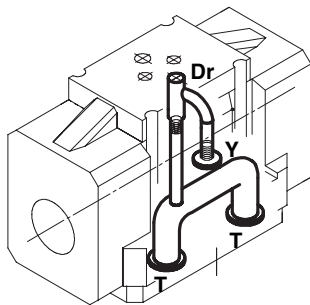
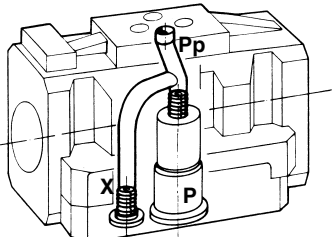
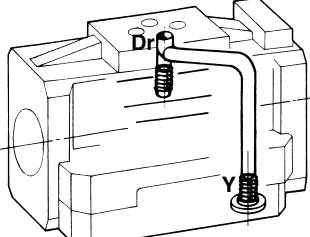
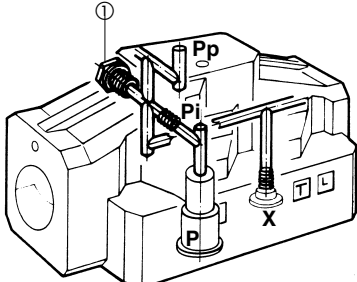
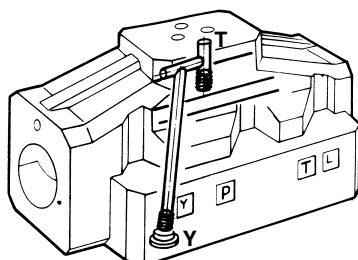
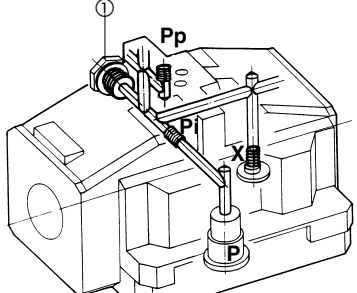
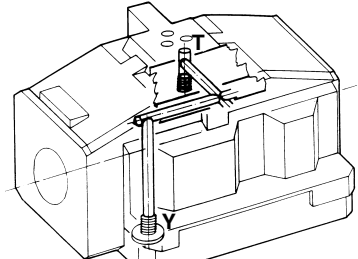
<p><b>DPH*-1</b></p> <p><b>Pilot channels</b></p> 	<p><b>Drain channels</b></p> 	<p><b>Internal piloting:</b> blinded plug SP-X300 in X; plug SP-X310A in Pp;</p> <p><b>External piloting:</b> blinded plug SP-X300 in Pp; plug SP-X310A in X;</p> <p><b>Internal drain:</b> blinded plug SP-X300 in Y;</p> <p><b>External drain:</b> blinded plug SP-X300 in Dr.</p>
<p><b>DPH*-2</b></p> <p><b>Pilot channels</b></p> 	<p><b>Drain channels</b></p> 	<p><b>Internal piloting:</b> blinded plug SP-X500 in X; plug SP-X512A in Pp;</p> <p><b>External piloting:</b> blinded plug SP-X500 in Pp; plug SP-X512A in X;</p> <p><b>Internal drain:</b> blinded plug SP-X300 in Y;</p> <p><b>External drain:</b> blinded plug SP-X300 in Dr.</p>
<p><b>DPH*-3</b></p> <p><b>Pilot channels</b></p> 	<p><b>Drain channels</b></p> 	<p><b>Internal piloting:</b> blinded plug SP-X300 in X; plug SP-X315A in Pp;</p> <p><b>External piloting:</b> blinded plug SP-X300 in Pi; plug SP-X315A in X;</p> <p><b>Internal drain:</b> blinded plug SP-X300 in Y;</p> <p><b>External drain:</b> blinded plug SP-X300 in T.</p>
<p>To reach the Pi orifice, remove plug ①</p>		
<p><b>DPH*-6</b></p> <p><b>Pilot channels</b></p> 	<p><b>Drain channels</b></p> 	<p><b>Internal piloting:</b> blinded plug SP-X300 in X; plug SP-X325A in Pp;</p> <p><b>External piloting:</b> blinded plug SP-X300 in Pi; plug SP-X325A in X;</p> <p><b>Internal drain:</b> blinded plug SP-X300 in Y;</p> <p><b>External drain:</b> blinded plug SP-X300 in T.</p>
<p>To reach the Pi orifice, remove plug ①</p>		

**13 DIMENSIONS FOR DPH\*-1 AND DPH\*-2 [mm]**

**DPH\*-1\***

**Mounting surface**  
**ISO 4401-AC-05-4 size 10**

Fastening bolts:  
 4 socket head screws CHC M6x40  
 Diameter of ports A,B, P, T:  $\varnothing = 11$  mm;  
 Diameter of ports X, Y:  $\varnothing = 5$  mm;  
 Seals: 5 OR 2050  
 2 OR 108

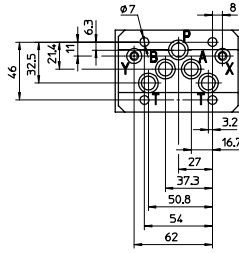

- P** = PRESSURE PORT
- A, B** = USE PORT
- T** = TANK PORT
- X** = EXTERNAL OIL PILOT PORT
- Y** = DRAIN PORT

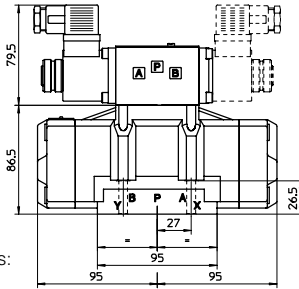

**DPHI-1\***

Mass of basic versions:  
 kg 6,5 (one solenoid)  
 kg 6,8 (two solenoids)

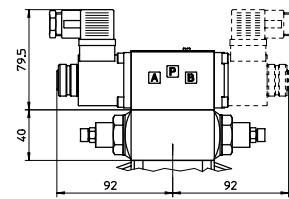
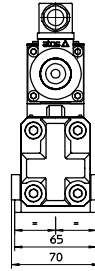

**DPHI-1\*/H**  
/H9

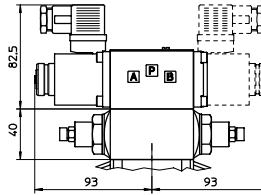

**DPHU-1\*/H**  
/H9

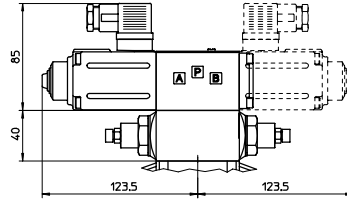

**DPHO-1\*/H**  
/H9

Mass of basic versions:  
 kg 6,9 (one solenoid)  
 kg 7,6 (two solenoids)

**DPH\*-2\***

**Mounting surface**  
**ISO 4401-AD-07-4 size 16**

Fastening bolts:  
 4 socket head screws M10x50  
 2 socket head screws M6x40  
 Diameter of ports A, B, P, T:  $\varnothing = 20$  mm;  
 Diameter of ports X, Y:  $\varnothing = 7$  mm;  
 Diameter of ports L:  $\varnothing = 5$  mm;  
 Seals: 4 OR 130, 3 OR 109

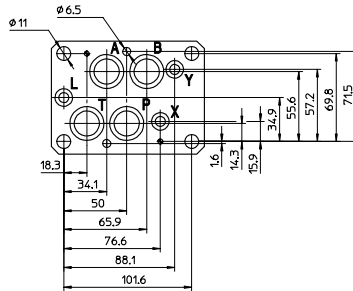

- P** = PRESSURE PORT
- A, B** = USE PORT
- T** = TANK PORT
- X** = EXTERNAL OIL PILOT PORT
- Y** = DRAIN PORT
- L** = DRAIN PORT FOR HYDRAULIC CENTERING DEVICE used only for /M versions

**Stroke adjustment device for option/S**

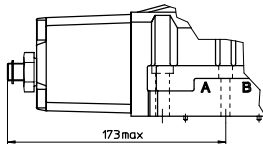

Only version  
 DPH\*-27\*/M

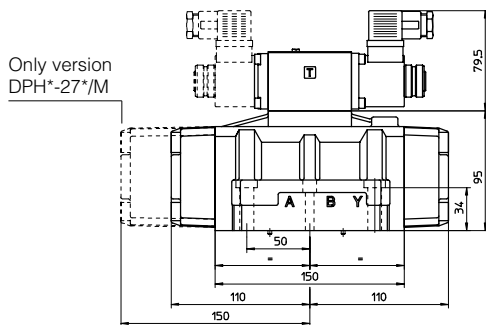

**DPHI-2\***

Mass of basic versions:  
 kg 9 (one solenoid)  
 kg 9,3 (two solenoids)

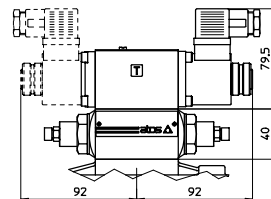

**DPHI-2\*/H**  
/H9

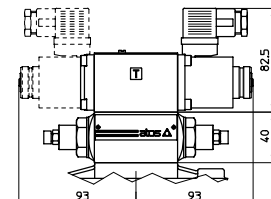

**DPHU-2\*/H**  
/H9

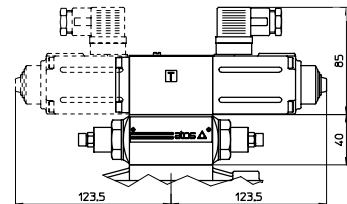

**DPHO-2\*/H**  
/H9

Mass of basic versions:  
 kg 9,4 (one solenoid)  
 kg 10,1 (two solenoids)

Overall dimensions refer to valves with connectors type SP-666

**14 MOUNTING SUBPLATES FOR DPH\*-1 AND DPH\*-2**

Valve	Subplate model	Ports location	Ports		Ø Counterbore [mm]		Mass [Kg]
			A, B, P, T	X, Y, (L)	A, B, P, T	X, Y, (L)	
DPH*-1	BA-428	Ports A, B, P, T, X, Y underneath;	G 3/4"	G 1/4"	36,5	21,5	5,6
DPH*-1	BA-434	Ports P, T, X, Y underneath; ports A, B on lateral side	G 3/4"	G 1/4"	36,5	21,5	5,5
DPH*-2	BA-418 (/DR)	Ports A, B, P, T, X, Y (L) underneath;	G 3/4"	G 1/4"	36,5	21,5	3,5
DPH*-2	BA-518 (/DR)	Ports A, B, P, T, X, Y (L) underneath;	G 1"	G 1/4"	46	21,5	8
DPH*-2	BA-519 (/DR)	Ports P, T, X, Y (L) underneath; ports A, B on lateral side	G 1"	G 1/4"	46	21,5	8

The drain port L (subplates /DR) is required only for valves with hydraulic pressure centering device (option /M)  
 The subplates are supplied with fastening bolts. For further details see table K280

15 DIMENSIONS FOR DPH\*-3 AND DPH\*-6 [mm]

**DPH\*-3\***  
**Mounting surface**  
 ISO 4401-AE-08-4 size 25  
 Fastening bolts:  
 6 socket head screws M12x50  
 Diameter of ports A, B, P, T:  $\varnothing = 24$  mm;  
 Diameter of ports X, Y:  $\varnothing = 7$  mm;  
 Diameter of port L:  $\varnothing = 5$  mm;  
 Seals: 4 OR 4112, 3 OR 3056

**Stroke adjustment device for option/S**

**DPHI-3\***

Mass of basic versions:  
 kg 14 (one solenoid)  
 kg 14,3 (two solenoids)

**DPHI-3\*/H /H9**

**DPHU-3\*/H /H9**

**DPHO-3\*/H /H9**

Mass of basic versions:  
 kg 14,4 (one solenoid)  
 kg 15,1 (two solenoids)

Legend:  
 P = PRESSURE PORT  
 A, B = USE PORT  
 T = TANK PORT  
 X = EXTERNAL OIL PILOT PORT  
 Y = DRAIN PORT  
 L = DRAIN PORT FOR HYDRAULIC CENTERING DEVICE used only for /M versions

**DPH\*-6\***  
**Mounting surface**  
 ISO 4401-AF-10-4 size 32  
 Fastening bolts:  
 6 socket head screws M20x80  
 Diameter of ports A, B, P, T:  $\varnothing = 34$  mm;  
 Diameter of ports X, Y:  $\varnothing = 7$  mm;  
 Diameter of ports L:  $\varnothing = 5$  mm;  
 Seals: 4 OR 4137, 3 OR 3081

**Stroke adjustment device for option/S**

**DPHI-6\***

Mass of basic versions:  
 kg 42 (one solenoid)  
 kg 42,3 (two solenoids)

**DPHI-6\*/H /H9**

**DPHU-6\*/H /H9**

**DPHO-6\*/H /H9**

Mass of basic versions:  
 kg 42,4 (one solenoid)  
 kg 43,1 (two solenoids)

Legend:  
 P = PRESSURE PORT  
 A, B = USE PORT  
 T = TANK PORT  
 X = EXTERNAL OIL PILOT PORT  
 Y = DRAIN PORT  
 L = DRAIN PORT FOR HYDRAULIC CENTERING DEVICE used only for /M versions

Overall dimensions refer to valves with connectors type SP-666

16 MOUNTING SUBPLATES FOR DPH\*-3 AND DPH\*-6

Valve	Subplate model	Ports location	Ports		Ø Counterbore [mm]		Mass [Kg]
			A, B, P, T	X, Y, (L)	A, B, P, T	X, Y, (L)	
DPH*-3	BA-508 (/DR)	Ports A, B, P, T, X, Y (L) underneath;	G 1"	G 1/4"	46	21,5	7
DPH*-3	BA-509 (/DR)	Ports P, T, X, Y (L) underneath; ports A, B on lateral	G 1"	G 1/4"	46	21,5	12,5
DPH*-6	BA-708 (/DR)	Ports A, B, P, T, X, Y (L) underneath;	G 1 1/2"	G 1/4"	63,5	21,5	17

The drain port L (subplates /DR) is required only for valves with hydraulic pressure centering device (option /M)  
 The subplates are supplied with fastening bolts. For further details see table K280