

Proportional reducing valves type RZGO

direct operated, ISO 4401 size 06

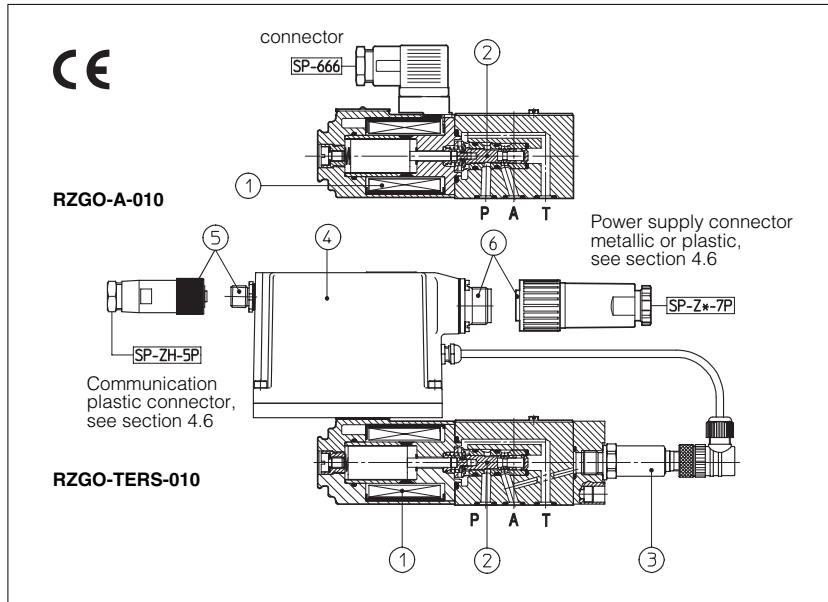

RZGO are 3-way proportional pressure reducing valves, direct operated with pressure regulation proportional to electronic reference signal.

They operate in association with electronic drivers, see table 8 which supply the proportional valve with proper current to align valve regulation to the reference signal supplied to the electronic driver.

They are available in different executions:

- -A, without integral pressure transducer.
- -AE, -AES, as -A plus analogue (AE) or digital (AES) integral electronics ④.
- -TERS with integral pressure transducer ③ plus digital electronics ④ preset in closed loop, featuring improved static and dynamic performances.
- -AERS as -TERS but without integral pressure transducer (predisposed for connection of remote pressure transducer).

The reduced pressure is controlled by the spool ②, directly operated by the solenoid ①.

The integral electronics ensures factory presetting, fine functionality plus valve-to-valve interchangeability and simplified wiring and installation.

Following communication interfaces ⑤ are available for the digital -AES, -TERS and -AERS executions:

- -PS, RS232 serial communication interface. The valve reference signal is provided with analogue commands via the 7 (or 12) pins connector ⑥
 - -BC, CANbus interface
 - -BP, PROFIBUS-DP interface
- In the -BC and -BP interfaces the valve reference signal is provided via fieldbus; during start up or maintenance, the valves can be operated with analogue signals via the 7 (or 12) pins connector ⑥.

The coils are fully plastic encapsulated (insulation class H), and the valves have antivibration, antishock and weather-proof features.

Surface mounting: ISO 4401 size 06.

Max flow: 12 l/min.

Max pressure: 210 bar.

1 MODEL CODE

RZGO - TERS - PS - 010 / 32 / * ** / *

Proportional pressure reducing valve size 06

A = without integral transducer
AE = as A plus integral electronics
AES = as A plus integral digital electronics
TERS = with integral digital electronics and pressure transducer
AERS = as TERS but with remote pressure transducer (to be ordered separately, see tab. G460)

Communication interfaces (only for AES, TERS and AERS)

PS = RS232 serial
BC = CANbus
BP = PROFIBUS-DP

Configuration:

0 = size 06 **10** = P, A and T ports

Pressure range

32 = 32 bar **100** = 100 bar **210** = 210 bar

Synthetic fluids

WG = water-glycol

PE = phosphate ester

Design number

Options, see section 4:

for -A execution:

6 = with 6 V_{DC} coil instead of standard 12V_{DC} coil

18 = with 18 V_{DC} coil instead of standard 12V_{DC} coil

for -AE executions:

I = current reference (4±20 mA)

Q = enable signal

for -AES, -TERS and -AERS executions:

Z = double power supply, enable and fault (12 pin connector)

C = remote pressure transducer with current feedback 4±20 mA (only for AERS execution)

2 HYDRAULIC CHARACTERISTICS (based on mineral oil ISO VG 46 at 50 °C)

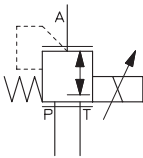
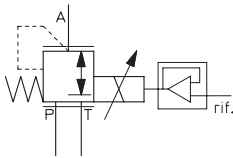
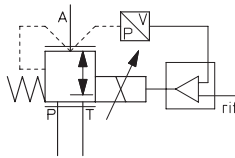
| Hydraulic symbols |  | | |  | | |  | | | |
|--|---|---------------------------------|-----|--|----|-----|---|-------|--|--|
| | RZGO-A | | | RZGO-AE RZGO-AES | | | RZGO-TERS RZGO-AERS | | | |
| Valve model | | | | | | | | | | |
| Max regulated pressure (Q = 1 l/min) | [bar] | 32 | 100 | 210 | 32 | 100 | 210 | | | |
| Min regulated pressure | [bar] | 0,8 (or actual value in T port) | | | | | | | | |
| Max pressure at port P | [bar] | 315 | | | | | | | | |
| Max pressures at port T | [bar] | 210 | | | | | | | | |
| Max flow | [l/min] | 12 | | | | | | | | |
| Response time 0 - 100% step signal (depending on installation) see section 6.4 | [ms] | ≤ 45 | | | | | | ≤ 40 | | |
| Hysteresis | [% of the max pressure] | ≤ 1,5 | | | | | | ≤ 0,3 | | |
| Linearity | [% of the max pressure] | ≤ 3 | | | | | | ≤ 1,0 | | |
| Repeatability | [% of the max pressure] | ≤ 2 | | | | | | ≤ 0,2 | | |

Above performance data refer to valves coupled with Atos electronic drivers, see section 8.

3 MAIN CHARACTERISTICS OF PROPORTIONAL PRESSURE REDUCING VALVES TYPE RZGO

| | |
|----------------------------|---|
| Assembly position | Any position |
| Subplate surface finishing | Roughness index, \sqrt{Ra} flatness ratio 0,01/100 (ISO 1101) |
| Ambient temperature | -20°C ÷ +70°C for -A execution; -20°C ÷ +60°C for -AE and -AES; -20°C ÷ +50°C for -TERS and -AERS |
| Fluid | Hydraulic oil as per DIN 51524 ... 535 for other fluids see section I |
| Recommended viscosity | 15 ÷ 100 mm ² /s at 40°C (ISO VG 15÷100) |
| Fluid contamination class | ISO 18/15 achieved with in line filters of 10 µm and β ₁₀ ≥ 75 (recommended) |
| Fluid temperature | -20°C +60°C (standard and /WG seals) -20°C +80°C (/PE seals) |

3.1 Electrical characteristics

| | |
|----------------------------------|--|
| Coil resistance R at 20°C | 3 ÷ 3,3 Ω for standard 12 V _{DC} coil; 2 ÷ 2,2 Ω for 6 V _{DC} coil; 13 ÷ 13,4 Ω for 18 V _{DC} coil |
| Max solenoid current | 2,4 A (1,8 A for version /32) for standard 12 V _{DC} coil; 3 A (2,25 A for version /32) for 6 V _{DC} coil; 1 A (0,8 A for version /32) for 18 V _{DC} coil |
| Max power | 40 Watt |
| Protection degree (CEI EN-60529) | IP65 for -A execution; IP65÷67 for -AE, -TERS and AERS executions, depending to the connector type (see sect. 4.6) |
| Duty factor | Continuous rating (ED=100%) |

4 INTEGRAL ELECTRONICS OPTIONS AND WIRING

4.1 Option /I

It provides the 4÷20 mA current reference signal and the current feedback signals instead of the standard 0÷10 V. It is normally used in case of long distance between the machine control unit and the valve or where the reference signal can be affected by electrical noise. In case of breakage of the reference signal cable, the valve functioning is disabled. For the digital executions -TERS and AERS the option **I** is available on request.

4.2 Option /Q

Safety option providing the possibility to enable or disable the valve functioning without cutting the power supply.

4.3 Option /Z

Safety option, specifically introduced for -BC and -BP communication interfaces, provides two separated electric power supplies for the digital electronic circuits and for the solenoid power supply stage. The Enable and Fault signals are also available. The option **Z** allows to interrupt the valve functioning by cutting the solenoid power supply (e.g. for emergency, as provided by the European Norms EN954-1 for components with safety class 2), but keeping energized the digital electronic circuits, thus avoiding fault conditions of the machine fieldbus controller.

For the electrical wiring, see tab. G115 and G205.

4.4 Option /C

The valve electronics is set to receive the 4÷20 mA feedback signal from the remote pressure transducer, instead of the standard 0÷10 V.

4.5 Integral electronics wiring

For the electric wiring shielded cables must be provided: the shield must be connected to the power supply zero **on the generator side**, see tab. **F003**

| POWER SUPPLY CONNECTOR | | | | |
|------------------------|---|---|--|---|
| PIN | SIGNAL DESCRIPTION | -AE, -AES, -TERS, -AERS | -AE/I (-TERS/I, -AERS/I) | -AE/Q |
| A | Power supply 24 V _{DC} | Stabilized: +24V _{DC} | | |
| B | Power supply zero | Filtered and rectified: V _{rms} = 21 ÷ 33 (ripple max 2V _{pp}) | | |
| C | Signal zero | Reference 0 V _{DC} | Reference 0 V _{DC} | Enabling input normal working 9 ÷ 24 V _{DC} |
| D | Input signal + | 0 ÷ 10 V _{DC} | 4 ÷ 20 mA | 0 ÷ 10 V |
| E | Input signal - | | | |
| F | Monitor driving current (for -AE, -AES) regulated pressure (for -TERS, -AERS) | 0 ÷ 10 V referred to pin C (signal 0 V _{DC}) 1V = 1A 1V = 10% of regulated pressure | 0 ÷ 5 V (-AE/I) 4 ÷ 20 mA (-TERS/I) 1V = 1A 4 ÷ 20 mA = 0÷100% of regulated pressure | 0 ÷ 5 V referred to pin B (signal 0 V _{DC}) 1V = 1A - |
| G | Earth | Connect only when the power supply is not conform to VDE 0551 (CEI 14/6) | | |

| COMMUNICATION INTERFACE CONNECTORS (-AES, -TERS, -AERS) | | | | | |
|---|-------------------------------|------------------------------|--|---------------------|---|
| Communication options | -PS (RS232) male connector | -BC (CAN Bus) male connector | -BP (PROFIBUS-DP) female connector (reverse key) | | |
| Pin number Signal description | 1 | NC | CAN_SHLD | +5V | |
| | | Not Connected | Shield | Termination voltage | |
| | 2 | NC | NC | LINE -A | |
| | | Not Connected | Not Connected | Bus line (high) | |
| | 3 | RS_GND | CAN_GND | DGND | Signal zero data line / termination voltage |
| 4 | RS_RX | CAN_H | LINE-B | Bus line (low) | |
| | Valves receiving data line | Bus line (high) | SHIELD | Shield | |
| 5 | RS_TX | CAN_L | | | |
| | Valves transmitting data line | Bus line (low) | | | |

| PRESSURE TRANSDUCER CONNECTOR (-AERS) see section Z | | |
|---|------------------|-----------------|
| PIN | standard version | option /C |
| 1 | Pressure signal | Pressure signal |
| 2 | Not connected | Not connected |
| 3 | Power supply | Power supply |
| 4 | GND | Not connected |

Note:

- electrical signals (e.g. feedback signals) processed by valve electronics must not be used to switch off the machine safety functions. This is in accordance with the European standards (Safety requirements of fluid technology systems and components - hydraulics, EN 982).
- installation notes with basic information for commissioning and start-up are always supplied with the relevant components, together with the specific technical tables.

4.6 Model codes of power supply and communication connectors

| VALVE VERSION | -A | -AE, -AES, -TERS, -AERS | -AES/Z, -TERS/Z, -AERS/Z | -RS232 (-PS) OR CANBUS (-BC) | PROFIBUS (-BP) | PRESSURE TRANSDUCER only for AERS |
|-------------------|--------|-------------------------|--------------------------|------------------------------|-----------------|-----------------------------------|
| CONNECTOR CODE | SP-666 | SP-ZH-7P (1) | SP-ZM-7P (1) | SP-ZH-12P (1) | SP-ZH-5P/BP (1) | SP-ZH-4P-M8/5 (1)(2) |
| PROTECTION DEGREE | IP65 | IP67 | IP66 | IP65 | IP67 | IP67 |

(1) to be ordered separately (2) M8 connector moulded on cable 5 mt length

5 PROGRAMMING DEVICES

The functional parameters of the digital valves, as the bias, scale, ramp and linearization of the regulation characteristic, can be easily set and optimized with graphic interface by using the following software programming devices suitable for standard PC:

KIT-E-SW-PS for electronics with RS232 interface (option **-PS**);

KIT-E-SW-PS-TERS only for -TERS-PS electronics - simplified version of KIT-E-SW-PS with only bias and scale settings

KIT-E-SW-BC for electronics with CANbus interface (option **-BC**)

KIT-E-SW-BP for electronics with PROFIBUS-DP interface (option **-BP**)

see tab. G500 for complete information about the programming device kits and for the PC minimum requirements.

Only for the -BC and -BP communication options, the functional parameters can be alternatively set via fieldbus through the machine control unit, using the standard communication protocol implemented by Atos.

The protocol operating instructions to be implemented in the standard protocols (DS301V4.02, DSP408 for CANbus and DPVO for PROFIBUS-DP) are described in the user manuals MAN-S-BC (for -BC option) and MAN-S-BP (for -BP option) supplied with the relevant programming device kits.

The above programming devices have to be ordered separately.

6 DIAGRAMS (based on mineral oil ISO VG 46 at 50 °C)

6.1 Regulation diagrams

with flow rate $Q = 1 \text{ l/min}$

- 1** = RZGO-A, RZGO-AE, RZGO-AES
- 2** = RZGO-TERS, RZGO-AERS

Notes:

- 1) For the valves with digital electronics the regulation characteristic can be modified by setting the internal software parameters, see tab. G500.
- 2) For executions -A, -AE and -AES the presence of counter pressure at port T can alter the effective pressure regulation.

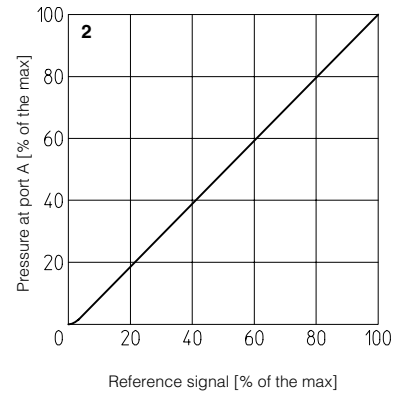
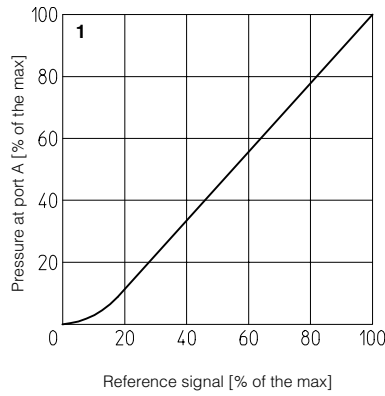

6.2 Pressure/flow diagrams

with reference pressure set with $Q = 1 \text{ l/min}$

- 3** = RZGO-A, RZGO-AE, RZGO-AES
- 4** = RZGO-TERS, RZGO-AERS

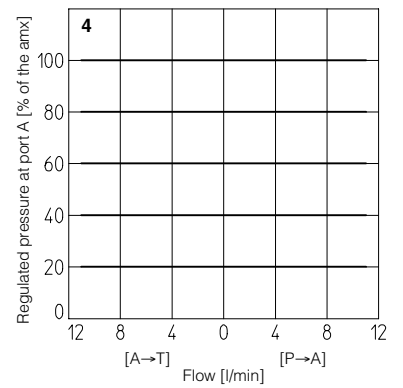
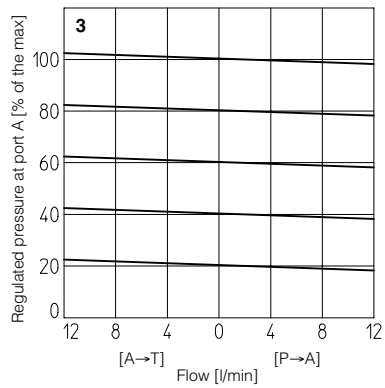

6.3 Pressure drop/flow diagram

with reference signal "null"

- 5** = Pressure drops vs. flow P-A (for all the executions)
- 6** = Pressure drops vs. flow A-T (for all the executions)

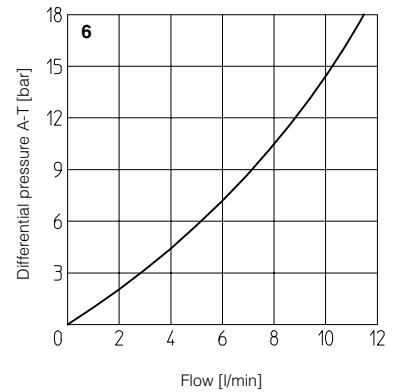
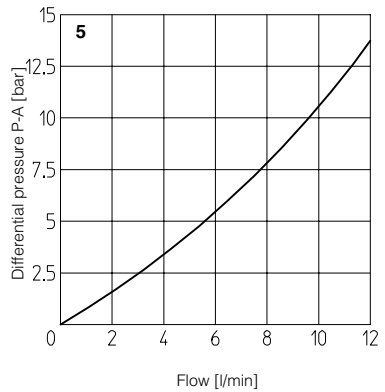

6.4 Dynamic response

The response times in section 2 have to be considered as average values.

The integral closed loop control of -TERS and -AERS valves is affected by the stiffness of the hydraulic circuit: greater is the stiffness of the circuit, the better are the performances. The valves dynamic performances can be optimized depending on the stiffness characteristics of the hydraulic circuit, by setting the internal software parameters. This regulation is particularly helpful in case of circuits with accumulators and/or with great fluid volumes and/or with long hoses.

7 INSTALLATION DIMENSIONS [mm]

RZGO-A

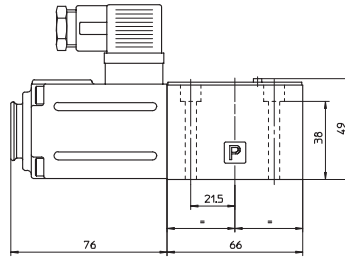
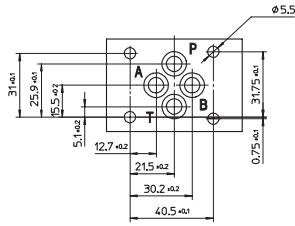

Mounting surface

ISO 4401-AB-03-4 size 06

Fastening bolts:
4 socket head screws M5 x 50
Seals: 4 OR 108
Ports P, A, T: $\varnothing = 5$ mm
Port B: not used

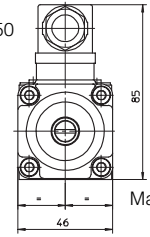

Mass: 1,8 Kg

**RZGO-AE
RZGO-AES-***
(dotted line)

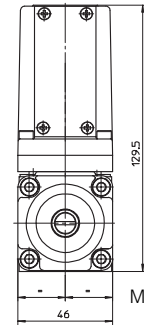
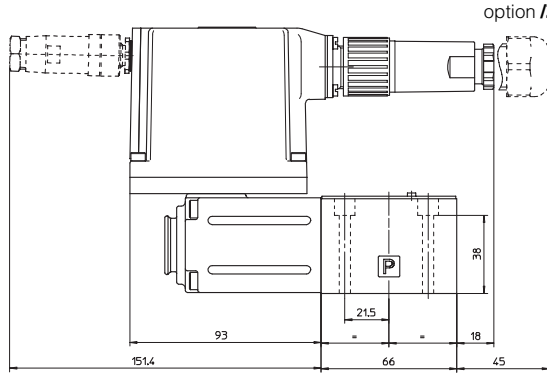

Mass: 2,5 Kg

RZGO-TERS-*

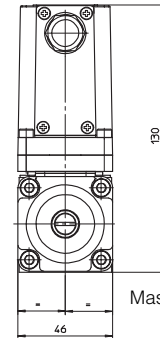
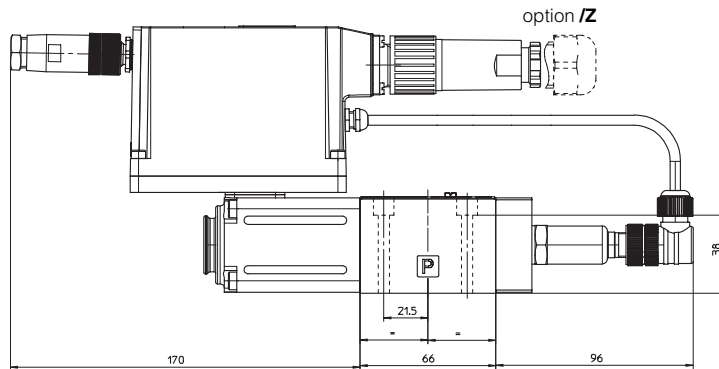

Mass: 2,7 Kg

RZGO-AERS-*

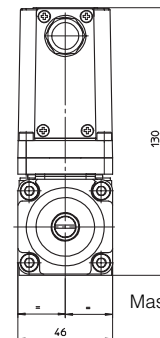
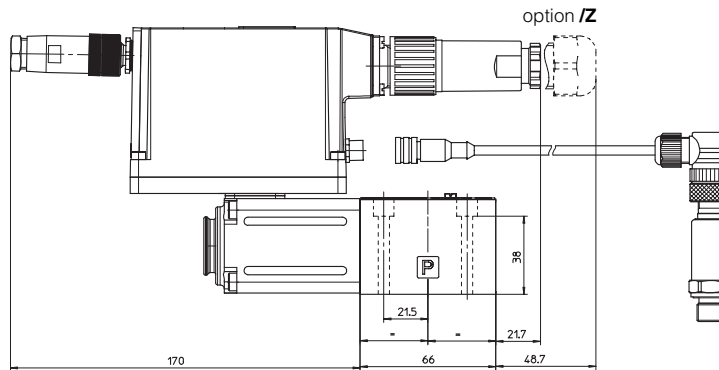

Mass: 2,6 Kg

8 ELECTRONIC DRIVERS FOR RZGO-A

| Valve model | -A | | | | -AE | -AES | -TERS | -AERS |
|---------------|-------------|-------------|-------------|-------------|------------|-------------|--------------|--------------|
| Drivers model | E-MI-AC-01F | E-BM-AC-01F | E-ME-AC-01F | E-PP-AC-01F | E-RI-AE | E-RI-AES | E-RI-TERS | E-RI-AERS |
| Data sheet | G010 | G025 | G035 | G100 | G110 | G115 | G205 | |

For complete information about the drivers characteristics and relevant options, see the technical data sheet specified in the table.

9 MOUNTING PLATES

| Model | Ports location | Gas Ports A-B-P-T | \varnothing Counterbore [mm] A-B-P-T | Mass [kg] |
|--------|---|----------------------|--|--------------|
| BA-202 | Ports A, B, P, T underneath; | 3/8" | - | 1,2 |
| BA-204 | Ports P, T underneath; Ports A, B on lateral side | 3/8" | 25,5 | 1,8 |
| BA-302 | Ports A, B, P, T underneath; | 1/2" | 30 | 1,8 |