

Proportional directional valves type DPZO-A*

two stage without position transducer, ISO 4401 sizes 10, 16 and 25

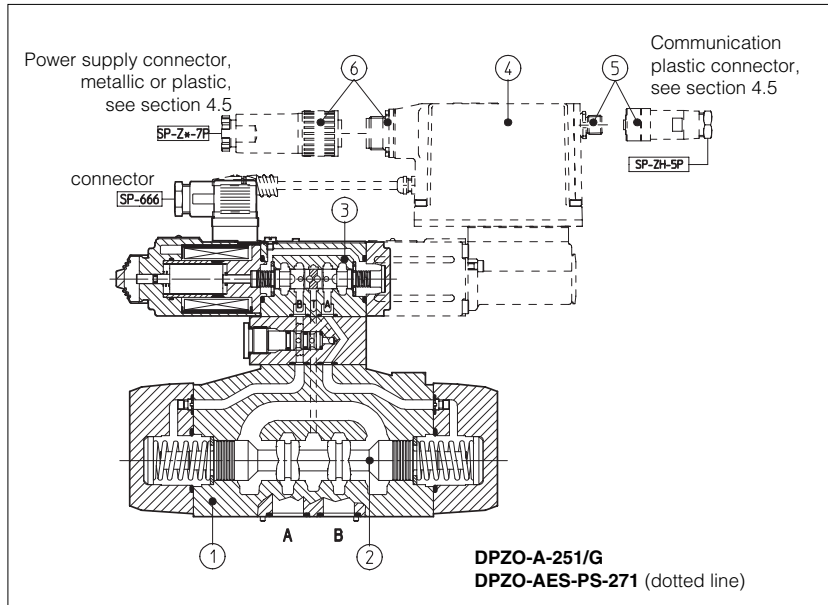

DPZO-A* are two stage proportional valves without position transducer, which provide both directional and non compensated flow control according to the electronic reference signal.

They operate in association with electronic drivers, see section 9, which supply the proportional valves with correct current signal to align valve regulation to the reference signal supplied to the electronic driver.

- They are available in different executions:
- -A, without position transducer;
 - -AE, -AES as -A plus analogue (AE) or digital (AES) integral electronics 4.

The 4-way spool 2, sliding into a 5-chambers body 1, is piloted in open loop by the proportional pressure reducing valve 3.

The integral electronics 4 ensures factory presetting, fine functionality plus valve-to-valve interchangeability and simplified wiring and installation.

Following communication interfaces 5 are available for the digital -AES execution:

- -PS, RS232 serial communication interface. The valve reference signal is provided with analogue commands via the 7 (or 12) pins connector 6.
- -BC, CANbus interface
- -BP, PROFIBUS-DP interface

In the -BC and -BP interfaces the valve reference signal is provided via fieldbus; during start up or maintenance, the valves can be operated with analogue signals via the 7 (or 12) pins connector 6.

The coils are fully plastic encapsulated (insulation class H) and valves have anti-vibration, antishock and weather-proof features.

Surface mounting: ISO 4401 size 10, 16 and 25.

Max flow respectively up to 135 l/min, 340 l/min and 680 l/min with valve differential pressure $\Delta p = 30$ bar, see section 2.
 Max pressure: 350 bar.

1 MODEL CODE

DPZO	-AES-PS	2	7	1 - D	5	*	**	/*
Piloted proportional directional valve		Valve size: 1 = 10 2 = 16 3 = 25		Configuration, see section 2: 5 = external plus central position, spring centered 7 = 3 positions; spring centered		Options: B = solenoid and integral electronics at side of port B of the main stage; D = internal drain E = external pilot G = pressure reducing valve for piloting		Synthetic fluids: WG = water-glycol PE = phosph. ester
A = without position transducer AE = as A plus integral electronics AES = as A plus integral digital electronics		Communication interfaces (only for AES) PS = RS232 serial BC = CANbus BP = PROFIBUS-DP		Spool overlapping in central position, see section 2: 1 = P, A, B, T positive overlapping 3 = P positive overlapping; A, B, T negative overlapping		for -A execution: 6 = with 6 V _{DC} coil instead of standard 12 V _{DC} coil 18 = with 18 V _{DC} coil instead of standard 12 V _{DC} coil		Design number
Spool type L = linear; S = progressive D = as S, but with P-A = Q, P-B = Q/2		for -AE execution: I = current reference (4±20 mA) Q = enable signal		for -AES execution: Z = double power supply, enable and fault (12 poles connector)		Spool size: 3, 5 see section 2		

2 HYDRAULIC CHARACTERISTICS (based on mineral oil ISO VG 46 at 50 °C)

Valve model	DPZO-1			DPZO-2			DPZO-3					
	L5	S5	D5	S3	D3	L5	S5	D5	L5	S5	D5	
Spool type and size	Ports P, A, B, X = 350; T = 250; Y = 0											
Pressure limits, see sect. 6.4 [bar]												
Max flow [l/min]												
at $\Delta p = 10$ bar (1)	80	80	80 : 50	130	130 : 80	200	180	180 : 130	390	360	360 : 220	
at $\Delta p = 30$ bar	135	135	135 : 85	225	225 : 135	340	310	310 : 225	680	620	620 : 380	
at Δp max = (...) bar	170 (315)	170 (315)	170 (315)	500 (150)	500 (150)	710 (130)	640 (130)	640 (130)	1350 (120)	1250 (120)	1250 (120)	
Response time (2) [ms]	< 80			< 100			< 120					
Hysteresis [%]	≤ 5%			≤ 5%			≤ 5%					
Repeatability	± 1%			± 1%			± 1%					

Above performance data refer to valves coupled with Atos electronic drivers, see section 9.

(1) For different Δp , the max flow is in accordance to the diagrams in section 6.2.

(2) Reponse times at step signal (0%→100%) are measured from 10% to 90% of step value and are strictly referred to the valve regulation.

3 MAIN CHARACTERISTICS OF PROPORTIONAL DIRECTIONAL VALVES TYPE DPZO-A*

Assembly position	Any position
Subplate surface finishing	Roughness index, $\sqrt{0.4}$ flatness ratio 0,01/100 (ISO 1101)
Ambient temperature	-20°C ÷ +70°C for -A execution; -20°C ÷ +60°C for -AE and -AES executions
Fluid	Hydraulic oil as per DIN 51524 ... 535 for other fluids see section I
Recommended viscosity	15 ÷ 100 mm ² /s at 40°C (ISO VG 15÷100)
Fluid contamination class	ISO 18/15 achieved with in line filters of 10 µm and $\beta_{10} \geq 75$ (recommended)
Fluid temperature	-20°C +60°C (standard and /WG seals) -20°C +80°C (/PE seals)

3.1 Coils characteristics

	with 12 V _{DC} coil	with 6 V _{DC} coil	with 18 V _{DC} coil
Coil resistance R at 20°C	3 ÷ 3,3 Ω	2 ÷ 2,2 Ω	13 ÷ 13,4 Ω
Max. solenoid current	2,2 A	2,75 A	1 A
Max. power		30 Watt	
Protection degree (CEI EN-60529)	IP65 for -A execution; IP65÷67 for -AE and -AES executions, depending to the connector type (see sect. 4.5)		
Relative duty factor	Continuous rating (ED=100%)		

4 INTEGRAL ELECTRONICS OPTION AND WIRING

4.1 Option /I

It provides the 4÷20 mA current reference signal instead of the standard 0÷10 V. It is normally used in case of long distance between the machine control unit and the valve or where the reference signal can be affected by electrical noise. In case of breakage of the reference signal cable, the valve functioning is disabled.

4.2 Option /Q

Safety option providing the possibility to enable or disable the valve functioning without cutting the power supply.

4.3 Option /Z

Safety option, specifically introduced for -BC and -BP communication interfaces, provides two separated electric power supplies for the digital electronic circuits and for the solenoid power supply stage. The Enable and Fault signals are also available. The option **Z** allows to interrupt the valve functioning by cutting the solenoid power supply (e.g. for emergency, as provided by the European Norms EN954-1 for components with safety class 2), but keeping energized the digital electronic circuits, thus avoiding fault conditions of the machine fieldbus controller.

For the electrical wiring of -AES, electronics with option **Z** (12 poles connector), see tab. G115.

4.4 Integral electronics wiring

For the electric wiring shielded cables must be provided: the shield must be connected to the power supply zero **on the generator side**, see tab. **F003**

POWER SUPPLY CONNECTOR				
PIN	SIGNAL DESCRIPTION	-AE, -AES	-AE/I	-AE/Q
A	Power supply 24 V _{DC}	Stabilized: +24V _{DC}		
B	Power supply zero	Filtered and rectified: V _{rms} = 21 ÷ 33 (ripple max 2V _{pp})		
C	Signal zero	Reference 0 V _{DC}	Reference 0 V _{DC}	Enabling input normal working 9 ÷ 24 V _{DC}
D	Input signal +	0 ÷ 10 V _{DC} (for single solenoid valve)	4 ÷ 20 mA	0 ÷ 10 V (for single solenoid valve)
E	Input signal -	± 10 V _{DC} (for double solenoid valve)		± 10 V (for double solenoid valve)
F	Monitor driving current	0 ÷ 5 V (for single solenoid valve) ± 5 V (for double solenoid valve) 1V = 1A (referred to pin C)		0 ÷ 5 V (for single solenoid valve) ± 5 V (for double solenoid valve) 1V = 1A (referred to pin B)
G	Earth	Connect only when the power supply is not conform to VDE 0551 (CEI 14/6)		

COMMUNICATION CONNECTORS (for -AES)				
Communication options	-PS (RS232) male connector	-BC (CAN Bus) male connector	-BP (PROFIBUS-DP) female connector (reverse key)	
Pin number Signal description	1	NC Not Connected	CAN_SHLD Shield	+5V Termination voltage
	2	NC Not Connected	NC Not Connected	LINE -A Bus line (high)
	3	RS_GND Signal zero data line	CAN_GND Signal zero data line	DGND Signal zero data line / termination voltage
	4	RS_RX Valves receiving data line	CAN_H Bus line (high)	LINE-B Bus line (low)
	5	RS_TX Valves transmitting data line	CAN_L Bus line (low)	SHIELD Shield

Note:

- electrical signals (e.g. actual - feedback signals) acquired via valve electronics must not be used to switch off the machine safety functions. This is in accordance with the European standards (Safety requirements of fluid technology systems and components - hydraulics, EN-892).
- installation notes with basic information for commissioning and start-up, are always supplied with relevant components, together with the specific technical tables.

4.5 Model codes of power supply and communication connectors

VALVE VERSION	-A	-AE, -AES		-AES/Z	-RS232 (-PS) OR CANBUS (-BC)	PROFIBUS (-BP)
CONNECTOR CODE	SP-666	SP-ZH-7P (1)	SP-ZM-7P (1)	SP-ZH-12P (1)	SP-ZH-5P (1)	SP-ZH-5P/BP (1)
CONNECTOR CODE	IP65	IP67	IP66	IP65	IP67	IP67

(1) to be ordered separately

5 PROGRAMMING DEVICES

The functional parameters of the digital valves, as the bias, scale, ramp and linearization of the regulation characteristic, can be easily set and optimized with graphic interface by using the following software programming devices suitable for standard PC:

KIT-E-SW-PS for electronics with RS232 interface (option **-PS**)

KIT-E-SW-BC for electronics with CANbus interface (option **-BC**)

KIT-E-SW-BP for electronics with PROFIBUS-DP interface (option **-BP**)

see tab. G500 for complete information about the programming device kits and for the PC minimum requirements.

Only for the -BC and -BP communication options, the functional parameters can be alternatively set via fieldbus through the machine control unit, using the standard communication protocol implemented by Atos.

The protocol operating instructions to be implemented in the standard protocols (DS301V4.02, DSP408 for CANbus and DPVO for PROFIBUS-DP) are described in the user manuals MAN-S-BC (for -BC option) and MAN-S-BP (for -BP option) supplied with the relevant programming device kits.

The above programming devices have to be ordered separately.

6 DIAGRAMS (based on mineral oil ISO VG 46 at 50 °C)

6.1 Regulation diagrams

DPZO-1:

- 1 = linear spool L5
2 = differential spool S5, D5

DPZO-2:

- 3 = progressive spool S3, D3
4 = progressive spool S5, D5
5 = linear spool L5

DPZO-3:

- 6 = linear spool L5
7 = progressive spool S5, D5

Note:

- For the valves with digital electronics, the regulation characteristic can be modified by setting the internal software parameters, see tab. G500.
- Hydraulic configuration:
Reference signal 0 ÷ +10 V P → A / B → T
12 ÷ 20 mA (also for option /B)

Reference signal 0 ÷ +10 V P → B / A → T
4 ÷ 12 mA (also for option /B)

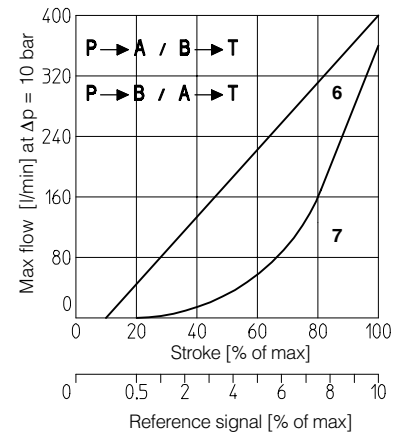
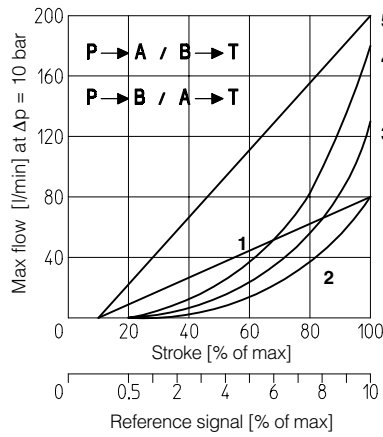

6.2 Flow /Δp diagram

Stated at 100% of valve stroke

DPZO-T-1:

- 1 = spool L5, S5, D5

DPZO-T-2:

- 2 = spool L5, S5, D5
3 = spool S3, D3

DPZO-T-3:

- 4 = spool L5, S5, D5

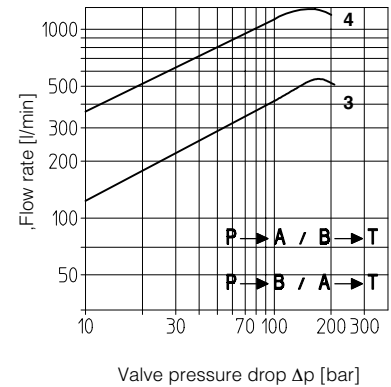
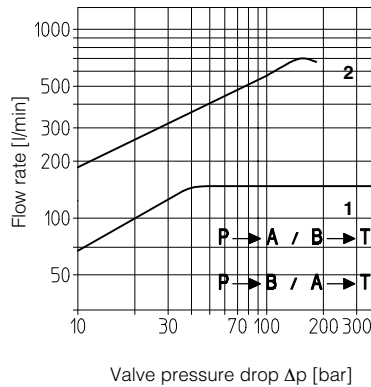

6.3 Operation as throttle valve

Single solenoid valves (*51) can be used as simple throttle valves:
Pmax = 250 bar
For this application, the use of valve -T, -TE or -TES (see tab. F172) is advisable (consult our technical office)

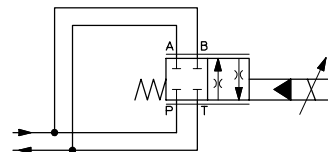

	VALVE TYPE		
	DPZO-*1	DPZO-*2	DPZO-*3
Max flow [l/min]	300	750	1200

6.4 Oil ports configuration

The standard configuration is internal pilot through port P and external drain through port Y. If the working pressure is over 100 bar, select option /G to reduce the piloting pressure or select the external pilot (option /E).
The minimum piloting pressure is 30 bar. In case the system pressure could drop at values lower than 30 bar, select the external pilot (option /E).
The internal drain, option /D, can be selected only if the backpressure on port T is < 1 bar.

DPZO-1

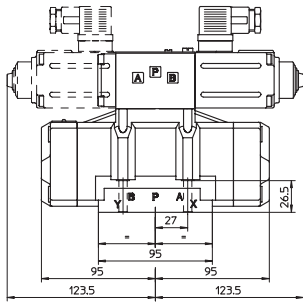

DPZO-A-1

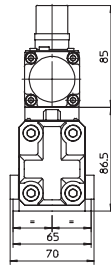

Mounting surface - ISO 4401-AC-05-4 size 10

Fastening bolts: 4 socket head screws M6x40

Seals: 5 OR 2050; 2 OR 108

Diameter of ports A, B, P, T: $\varnothing = 11$ mm;

Diameter of ports X, Y: $\varnothing = 5$ mm;

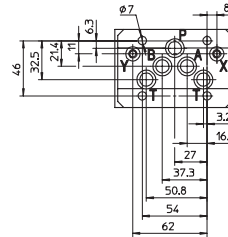

- P = PRESSURE PORT
- A, B = USE PORT
- T = TANK PORT
- X = EXTERNAL PILOT PORT
- Y = DRAIN PORT

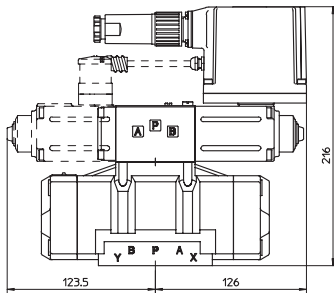

DPZO-AE-1

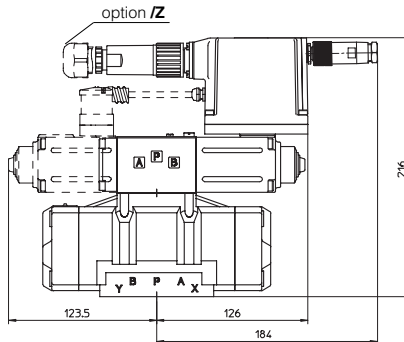

DPZO-AES*-1

NOTE: The overall height is increased by 30 mm for /G option (only for -A, -AE). For option /B the proportional solenoid (in case of single solenoid execution) or the integral electronics (in case of execution -AE and -AES) is at side of port B of the main stage. Dotted line for configuration type "7"

Mass [kg]

	A	AE, AES
DPZO-*15*	7,7	8,1
DPZO-*17*	8,6	9,1

DPZO-2

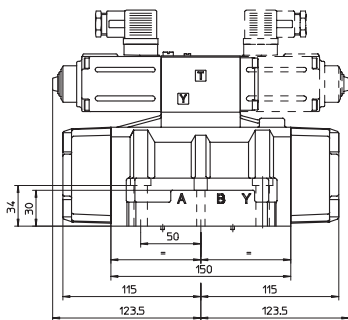

DPZO-A-2

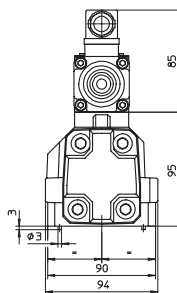

Mounting surface - ISO 4401-AD-07-4 size 16

Fastening bolts: 4 socket head screws M10x50

2 socket head screws M6x40

Seals: 4 OR 130; 3 OR 109

Diameter of ports A, B, P, T: $\varnothing = 20$ mm;

Diameter of ports X, Y: $\varnothing = 7$ mm;

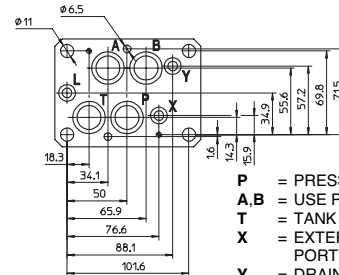

- P = PRESSURE PORT
- A, B = USE PORT
- T = TANK PORT
- X = EXTERNAL PILOT PORT
- Y = DRAIN PORT

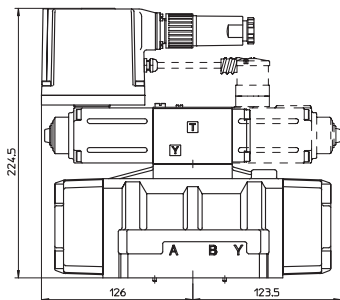

DPZO-AE-2

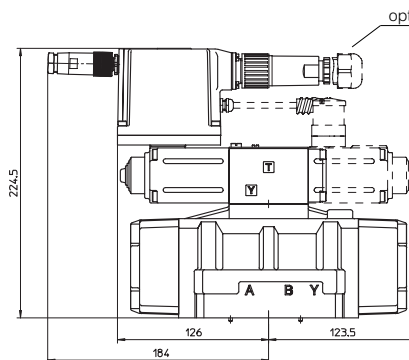

DPZO-AE*-2

NOTE: The overall height is increased by 30 mm for /G option (only for -A, -AE). For option /B the proportional solenoid (in case of single solenoid execution) or the integral electronics (in case of execution -AE and -AES) is at side of port B of the main stage. Dotted line for configuration type "7"

Mass [kg]

	A	AE, AES
DPZO-*25*	11,9	12,3
DPZO-*27*	12,8	13,3

8 INSTALLATION DIMENSIONS FOR DPZO-3 [mm]

DPZO-3

Mounting surface - ISO 4401-AE-08-4 size 25

Fastening bolts: 6 socket head screws M12x50

Seals: 4 OR 4112; 3 OR 3056

Diameter of ports A, B, P, T: $\varnothing = 24$ mm;

Diameter of ports X, Y: $\varnothing = 7$ mm;

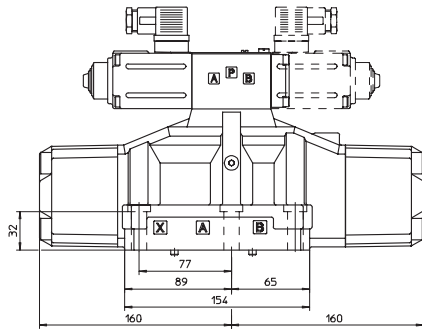

DPZO-A-3

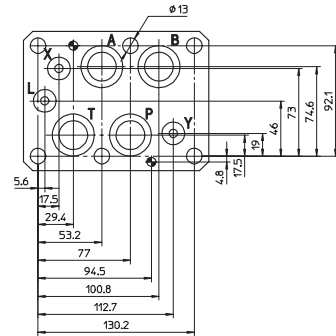
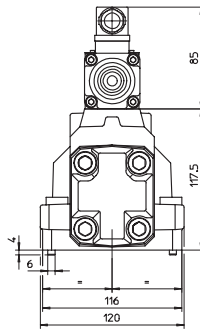

- P = PRESSURE PORT
- A, B = USE PORT
- T = TANK PORT
- X = EXTERNAL PILOT PORT
- Y = DRAIN PORT

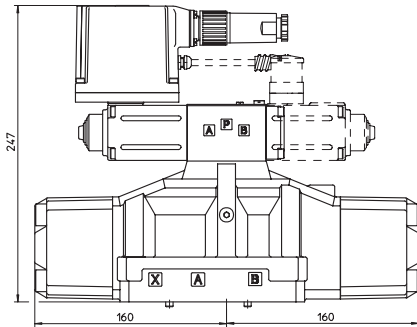

DPZO-AE-3

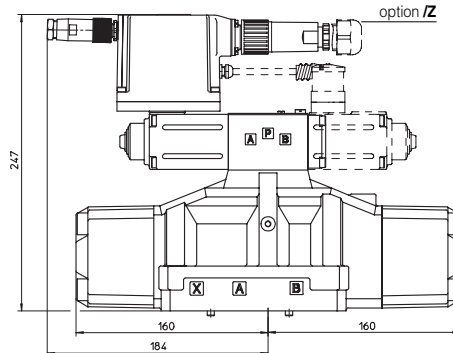

DPZO-AES-3

NOTE: The overall height is increased by 30 mm for /G option. For option /B the proportional solenoid (in case of single solenoid execution) or the integral electronics (in case of execution - AE and -AES) is at side of port B of the main stage. Dotted line for configuration type "7"

Mass [kg]

	A	AE, AES
DPZO-*35*	17,1	17,5
DPZO-*37*	18	18,4

9 ELECTRONIC DRIVERS FOR DPZO-A*

Valve model	-A				-AE	-AES
Drivers model	E-MI-AC-0*F	E-BM-AC-0*F	E-ME-AC-0*F	E-RP-AC-0*F	E-RI-AE	E-RI-AES
Data sheet	G010	G025	G035	G100	G110	G115

For complete information about the drivers characteristics and relevant options, see the technical data sheet specified in the table.

10 MOUNTING SUBPLATES FOR DPZO-1, DPZO-2, DPZO-3

Size	Model	Ports locations	Gas ports		Ø Counterbore [mm]		Mass [Kg]
			A, B, P, T	X, Y	A, B, P, T	X, Y	
10	BA-428	Ports A, B, P, T, X, Y underneath;	3/4"	1/4"	36,5	21,5	5,6
	BA-434	Ports P, T, X, Y underneath; ports A, B on lateral side	3/4"	1/4"	36,5	21,5	5,5
16	BA-418	Ports A, B, P, T, X, Y underneath;	3/4"	1/4"	36,5	21,5	3,5
	BA-519	Ports P, T, X, Y underneath; ports A, B on lateral side	1"	1/4"	46	21,5	8
25	BA-508	Ports A, B, P, T, X, Y underneath;	1"	1/4"	46	21,5	7
	BA-509	Ports P, T, X, Y underneath; ports A, B on lateral side	1"	1/4"	46	21,5	12,5

