

Proportional directional valves type DPZO-T*

two stage, with position transducer, ISO 4401 sizes 10, 16 and 25

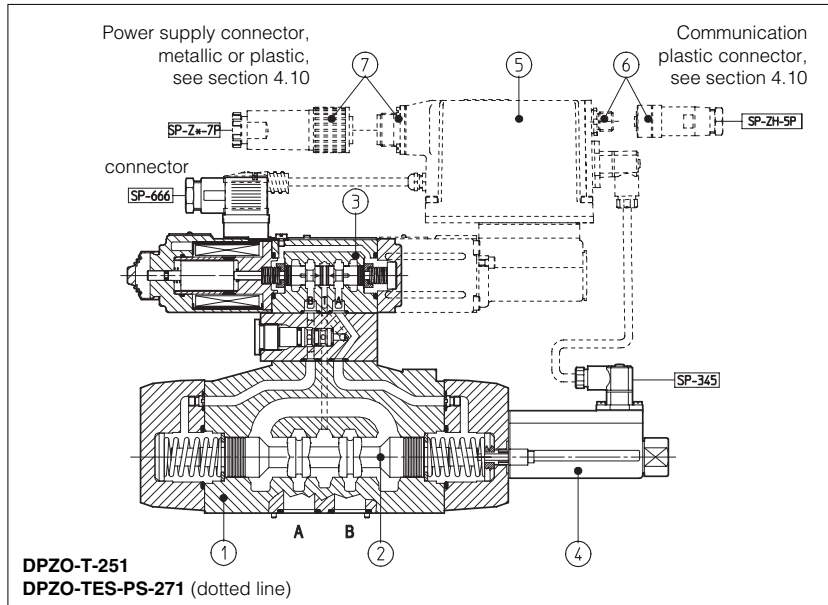

1 MODEL CODE

DPZO -TES- PS - 2 7 1 - D 5 * ** /*

Piloted proportional directional valve

T = with position transducer
TE = as T plus integral electronics
TES = as T plus integral digital electronics

Communication interfaces (only for TES)
PS = RS232 serial
BC = CANbus
BP = PROFIBUS-DP

Valve size:
1 = 10 **2** = 16 **3** = 25

Configuration, see section 2:
5 = external plus central position, spring centered
7 = 3 positions; spring centered

Spool overlapping in central position, see section 2:
1 = P, A, B, T positive overlapping
3 = P positive overlapping; A, B, T negative overlapping

Spool type
L = linear; **S** = progressive
D = as **S**, but with P-A = Q, P-B = Q/2

Synthetic fluids:
WG = water-glycol
PE = phosph. ester

Design number

Options:
B = solenoid and integral electronics at side of port B of the main stage;
D = internal drain
E = external pilot (through port X)
for -TE execution:
I = current reference (4÷20 mA)
F = fault signal
Q = enable signal
S = with logic state signals (12 poles connector)
Z = enable, fault and monitor signal (12 poles connector)
for -TES execution (12 poles connector):
Z = double power supply, enable and fault
SP = additional closed loop pressure control with multiple PID parameters set - **only for -PS**
ZP = as SP but with double power supply, enable and fault - **only for -BC and -BP**
C = remote pressure transducer with current feedback 4÷20 mA - **only for -TES/SP and -TES/ZP**

Spool size: **3, 5** see section 2

DPZO-T* are two stage proportional valves with position transducer on the main spool, which provide both directional and non compensated flow control according to the electronic reference signal.

They operate in association with electronic drivers, see section 9, which supply the proportional valves with correct current signal to align valve regulation to the reference signal supplied to the electronic driver.

They are available in different executions:

- -T, with position transducer ④;
- -TE, -TES as -T plus analogue (TE) or digital (TES) integral electronics.

The 4-way spool ② sliding into a 5-chambers body ①, is piloted by a proportional directional valve ③ and it is controlled in closed loop position by means of the LVDT transducer ④.

The integral electronics ⑤ ensures factory presetting, fine functionality plus valve-to-valve interchangeability and simplified wiring and installation.

Following communication interfaces ⑥ are available for the digital -TES execution:

- -PS, RS232 serial communication interface. The valve reference signal is provided with analogue commands via the 7 (or 12) pins connector ⑦.
- -BC, CANbus interface
- -BP, PROFIBUS-DP interface

In the -BC and -BP interfaces the valve reference signal is provided via fieldbus; during start up or maintenance, the valves can be operated with analogue signals via the 7 (or 12) pins connector ⑦.

To compensate flow variations due to modification of the load conditions, modular pressure compensators are available to keep a constant Δp across the valve (see tab. D150).

The coils are fully plastic encapsulated (insulation class H) and valves have anti-vibration, antishock and weather-proof features.

Surface mounting: ISO 4401 size 10, 16 and 25.

Max flow up to 135 l/min, 340 l/min and 680 l/min respectively with valve differential pressure $\Delta p = 30$ bar, see section 2. Max pressure: 350 bar.

2 HYDRAULIC CHARACTERISTICS (based on mineral oil ISO VG 46 at 50 °C)

Hydraulic symbols *71, *71/B *73 *51 *53 *51/B *53/B

Valve model	DPZO-1			DPZO-2			DPZO-3				
	L5	S5	D5	S3	D3	L5	S5	D5	L5	S5	D5
Spool type and size											
Pressure limits, see sect. 6.5 [bar]	Ports P, A, B, X = 350; T = 250; Y = 0										
Max flow [l/min]											
at $\Delta p = 10$ bar (1)	80	80	80 : 50	130	130 : 80	200	180	180 : 130	390	360	360 : 220
at $\Delta p = 30$ bar	135	135	135 : 85	225	225 : 135	340	310	310 : 225	680	620	620 : 380
at Δp max = (...) bar	170 (315)	170 (315)	170 (315)	550 (180)	550 (180)	760 (150)	690 (150)	690 (150)	1450 (140)	1350 (140)	1350 (140)
Response time (2) [ms]	< 80			< 100			< 120				
Hysteresis [%]	≤ 1%			≤ 1%			≤ 1%				
Repeatability	± 0,5%			± 0,5%			± 0,5%				

Above performance data refer to valves coupled with Atos electronic drivers, see section 9

(1) For different Δp , the max flow is in accordance to the diagrams in sections 6.2 and 7.2.

(2) Reponse times at step signal (0%→100%) are measured from 10% to 90% of step value and are strictly referred to valve regulation.

(3) In case of long interruption of the hydraulic supply to the pilot valve, the driver has to be switched off to avoid its overheating.

3 MAIN CHARACTERISTICS OF PROPORTIONAL DIRECTIONAL VALVES TYPE DPZO-T*

Assembly position	Any position
Subplate surface finishing	Roughness index, $\sqrt{0.4}$ flatness ratio 0,01/100 (ISO 1101)
Ambient temperature	-20°C ÷ +70°C for -T execution; -20°C ÷ +60°C for -TE and TES executions
Fluid	Hydraulic oil as per DIN 51524 ... 535 for other fluids see section I
Recommended viscosity	15 ÷ 100 mm ² /s at 40°C (ISO VG 15÷100)
Fluid contamination class	ISO 18/15 achieved with in line filters of 10 µm and $\beta_{10} \geq 75$ (recommended)
Fluid temperature	-20°C +60°C (standard and /WG seals) -20°C +80°C (/PE seals)

3.1 Coils characteristics

Coil resistance R at 20°C	3 ÷ 3,3 Ω
Max. solenoid current	2,6 A
Max. power	35 Watt
Protection degree (CEI EN-60529)	IP65 for -T execution; IP65÷67 for -TE and -TES executions, depending to the connector type (see sect. 4.10)
Duty factor	Continuous rating (ED=100%)

4 INTEGRAL ELECTRONICS OPTIONS AND WIRING

4.1 Option /I It provides the 4÷20 mA current reference signal and the current feedback signals instead of the standard 0÷10V (± 10V). It is normally used in case of long distance between the machine control unit and the valve or where the reference signal can be affected by electrical noise. In case of breakage of the reference signal cable, the valve functioning is disabled.

4.2 Option /F Safety option providing an output signal which switches to zero in case of interruption of the transducer feedback cable. In this condition the valve functioning is disabled.

4.3 Option /Q Safety option providing the possibility to enable or disable the valve functioning without cutting the power supply.

4.4 Option /S Option for diagnostic controls, providing three on-off output signals for the real time monitor of the valve's spool position (central, P→A or P→B). For the electrical wiring of -TE electronics with options /S (12 poles connector), see table G200.

4.5 Option /Z For -TE execution: option providing the same characteristics of /F and /Q plus the monitor signal of the spool position.

For -TES execution: safety option, specifically introduced for -BC and -BP fieldbus interfaces, provides two separated power supplies for the digital electronic circuits and for the solenoid power supply stage. The Enable and Fault signals are also available. The option /Z allows to interrupt the valve functioning by cutting the solenoid power supply (e.g. for emergency, as provided by the European Norms EN954-1 for components with safety class 2), but keeping energized the digital electronic circuits, thus avoiding fault conditions of the machine bus controller. For the electrical wiring of -TE and -TES electronics with option /Z (12 poles connector), see tab. G200 and G210.

4.6 Option /SP Option providing in addition to the standard valve functions, a closed loop control of the max pressure, thus realizing a P/Q regulation. A remote pressure transducer must be installed on the system and its feedback has to be interfaced to the valve. If the real value of the pressure in the system remains below the relevant reference signal, the driver regulates in closed loop the valve's spool position, according to the flow reference signal. When the real pressure become close to the relevant reference signal, the driver automatically performs the closed loop control of the pressure. This option permits to realize accurate dynamic pressure profiles. Up to 4 set of PID pressure parameters can be real time selected during the axis motion via on-off signals to the 12 poles connector to optimize the control performances in the different phases of the machine cycle. For additional information and for the electrical wiring, see tab. G210.

4.7 Option /ZP Integral digital P/Q controller providing the same characteristics of option /SP plus additional double power supply, enable and fault, like -TES/Z. In this option the multiple set of PID pressure parameters can be real time selected during the axis motion through the -BC or -BP interfaces. For additional information and for the electrical wiring, see tab. G210.

4.8 Option /C (compatible only with options /SP and /ZP) The valve electronics is set to receive 4÷20 mA signal from the remote pressure transducer instead of standard 0÷10 V. In case of breakage of the transducer feedback cable the driver functioning is disabled. For additional information and for the electrical wiring, see tab. G210.

4.9 Integral electronics wiring

For the electric wiring shielded cables must be provided: the shield must be connected to the power supply zero on the generator side, see tab. F003

POWER SUPPLY CONNECTOR					
PIN	SIGNAL DESCRIPTION	-TE, -TES	-TE/I	-TE/F	-TE/Q
A	Power supply 24 V _{dc}	Stabilized:	+24V _{dc}		
B	Power supply zero	Filtered and rectified:	V _{rms} = 21 ÷ 33 (ripple max 2V _{pp})		
C	Signal zero	Reference 0 V _{dc}	Reference 0 V _{dc}	Reference 0 V _{dc}	Enabling input normal working 9 ÷ 24 V _{dc}
D	Input signal +	0 ÷ 10 V _{dc} (for single solenoid valve)	4 ÷ 20 V _{dc}	0 ÷ 10 V _{dc} (for single solenoid valve)	
E	Input signal -	±10 V _{dc} (for double solenoid valve)		±10 V _{dc} (for double solenoid valve)	
F	Monitor	0 ÷ 10 V (for single solenoid valves) ±10 V (for double solenoid valves)	4 ÷ 20 mA referred to pin C (signal 0 V _{dc})	Fault signal alarm = 0 V _{dc}	0 ÷ 10 V (for single solenoid valves) ±10 V (for double solenoid valves)
	Spool position	1 V = 10% of spool position	4 ÷ 20 mA = 0÷100% of spool position	Normal working = +24 V _{dc}	1 V = 10% of spool position
G	Earth	Connect only when the power supply is not conform to VDE 0551 (CEI 14/6)			

COMMUNICATION CONNECTORS (for -TES)			
Communication options	-PS (RS232) male connector	-BC (CAN Bus) male connector	-BP (PROFIBUS-DP) female connector (reverse key)
Pin number Signal description	1 NC Not Connected	CAN_SHLD Shield	+5V Termination voltage
	2 NC Not Connected	NC Not Connected	LINE -A Bus line (high)
	3 RS_GND Signal zero data line	CAN_GND Signal zero data line	DGND Signal zero data line / termination voltage
	4 RS_RX Valves receiving data line	CAN_H Bus line (high)	LINE-B Bus line (low)
	5 RS_TX Valves transmitting data line	CAN_L Bus line (low)	SHIELD Shield

POSITION TRANSDUCER CONNECTOR (-T)	
PIN	Signal description
1	OUTPUT SIGNAL
2	SUPPLY -15 V _{dc}
3	SUPPLY +15 V _{dc}
4	GND

Note:

- electrical signals (e.g. actual - feedback signals) acquired via valve electronics must not be used to switch off the machine safety functions. This is in accordance with the European standards (Safety requirements of fluid technology systems and components - hydraulics, EN-892).
- installation notes with basic information for commissioning and start-up, are always supplied with relevant components, together with the specific technical tables.

4.10 Model codes of power supply and communication connectors

VALVE VERSION	-T		-TE, -TES		-TE/S, -TE/Z -TES/Z, /SP, /ZP	-RS232 (-PS) OR CANBUS (-BC)	PROFIBUS (-BP)	PRESSURE TRANSDUCER only for TES/SP, /ZP
	Power supply	Transducer						
CONNECTOR CODE	SP-666	SP-345	SP-ZH-7P (1)	SP-ZM-7P (1)	SP-ZH-12P (1)	SP-ZH-5P (1)	SP-ZH-5P/BP (1)	SP-ZH-4P-M8/5 (1)(2)
CONNECTOR CODE	IP65	IP65	IP67	IP66	IP65	IP67	IP67	IP67

(1) to be ordered separately (2) M8 connector moulded on cable 5 mt length

5 PROGRAMMING DEVICES

The functional parameters of the digital valves, as the bias, scale, ramp and linearization of the regulation characteristic, can be easily set and optimized with graphic interface by using the following software programming devices suitable for standard PC:

KIT-E-SW-PS for electronics with RS232 interface (option -PS)

KIT-E-SW-BC for electronics with CANbus interface (option -BC)

KIT-E-SW-BP for electronics with PROFIBUS-DP interface (option -BP)

see tab. G500 for complete information about the programming device kits and for the PC minimum requirements.

Only for the -BC and -BP communication options, the functional parameters can be alternatively set via fieldbus through the machine control unit, using the standard communication protocol implemented by Atos.

The protocol operating instructions to be implemented in the standard protocols (DS301V4.02, DSP408 for CANbus and DPVO for PROFIBUS-DP) are described in the user manuals MAN-S-BC (for -BC option) and MAN-S-BP (for -BP option) supplied with the relevant programming device kits.

The above programming devices have to be ordered separately.

6 DIAGRAMS (based on mineral oil ISO VG 46 at 50 °C)

6.1 Regulation diagrams

DPZO-1:
1 = linear spool L5
2 = differential spool S5, D5

DPZO-2:
3 = progressive spool S3, D3
4 = progressive spool S5, D5
5 = linear spool L5

DPZO-3:
6 = linear spool L5
7 = progressive spool S5, D5

Note:

1) For the valves with digital electronics, the regulation characteristic can be modified by setting the internal software parameters, see tab. G500.

2) Hydraulic configuration vs. reference signal:

(for double solenoid valves)
 Reference signal 0 ÷ +10 V P → A / B → T
 12 ÷ 20 mA (also for option /B)

Reference signal 0 ÷ -10 V P → B / A → T
 4 ÷ 12 mA (also for option /B)

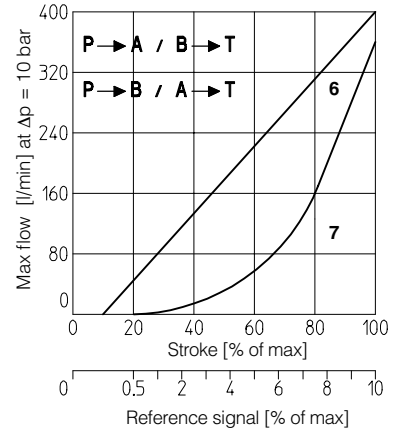
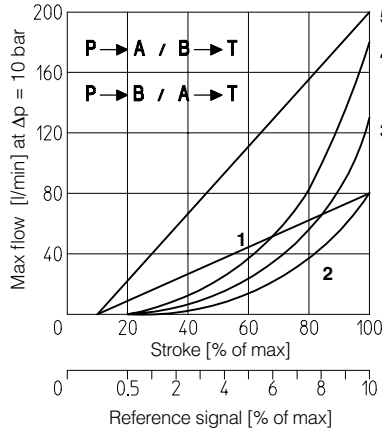

6.2 Operating diagrams

Flow /Δp diagram
 Stated at 100% of valve stroke

DPZO-1:
1 = spool L5, S5, D5

DPZO-2:
2 = spool L5, S5, D5
3 = spool S3, D3

DPZO-3:
4 = spool L5, S5, D5

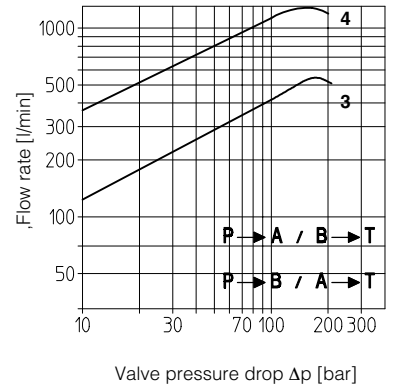
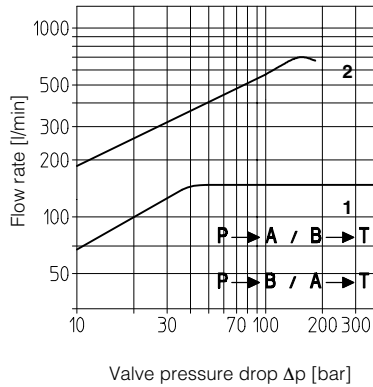

6.3 Operation as throttle valve

Single solenoid valves (*51) can be used as simple throttle valves:
 Pmax = 250 bar

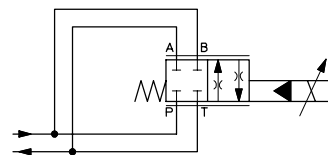

	VALVE TYPE		
	DPZO-*1	DPZO-*2	DPZO-*3
Max flow [l/min]	300	750	1200

6.4 Dynamic response

The response times in section 2 have to be considered as average values.
 For the valves with digital electronics the dynamics performances can be optimized by setting the internal software parameters.

6.5 Oil ports configuration

The standard configuration is internal pilot through port P and external drain through port Y. If the working pressure is over 100 bar, select option /G to reduce the piloting pressure or select the external pilot (option /E). The minimum piloting pressure is 30 bar. In case the system pressure could drops at values lower than 30 bar, select the external pilot (option /E). The internal drain, option /D, can be selected only if the backpressure on port T is < 1 bar.

DPZO-1

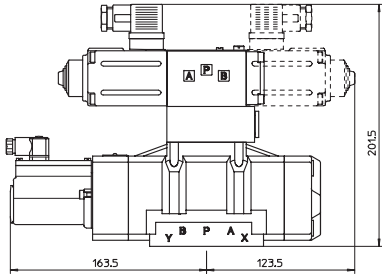

DPZO-T-1

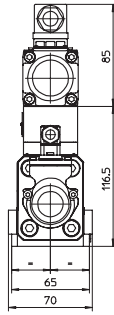

Mounting surface - ISO 4401-AC-05-4 size 10

Fastening bolts: 4 socket head screws M6x40

Seals: 5 OR 2050; 2 OR 108

Diameter of ports A, B, P, T: $\varnothing = 11$ mm;

Diameter of ports X, Y: $\varnothing = 5$ mm;

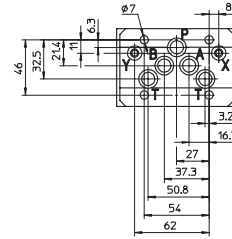

- P = PRESSURE PORT
- A,B = USE PORT
- T = TANK PORT
- X = EXTERNAL PILOT PORT
- Y = DRAIN PORT

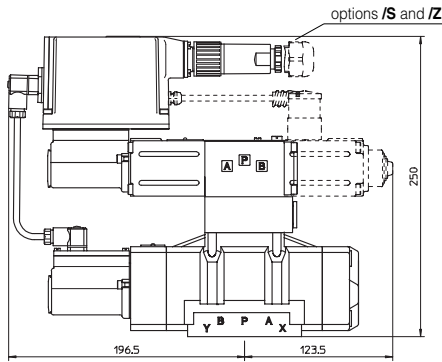

DPZO-TE-1

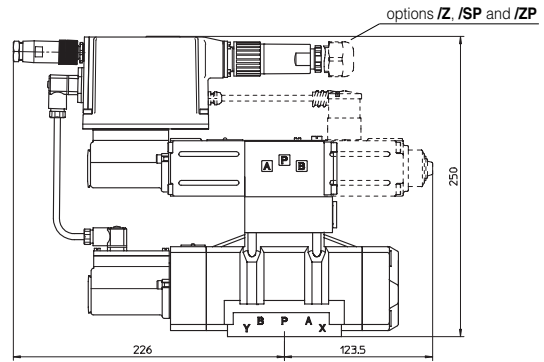

DPZO-TES*-1

Mass [kg]

	T	TE, TES
DPZO*-15*	7,7	8,1
DPZO*-17*	8,6	9,1

NOTE: For option /B the proportional solenoid and the integral electronics (in case of execution -TE and -TES) are at side of port B of the main stage. Dotted line for configuration type "7"

DPZO-2

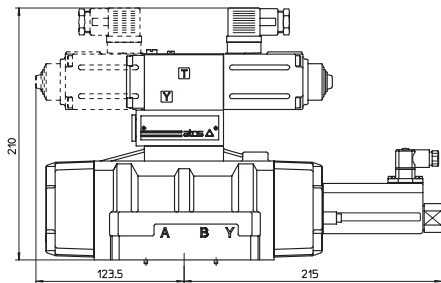

DPZO-T-2

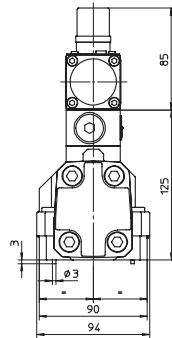

Mounting surface - ISO 4401-AD-07-4 size 16

Fastening bolts: 4 socket head screws M10x50

2 socket head screws M6x40

Seals: 4 OR 130; 3 OR 109

Diameter of ports A, B, P, T: $\varnothing = 20$ mm;

Diameter of ports X, Y: $\varnothing = 7$ mm;

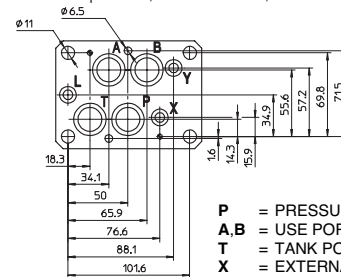

- P = PRESSURE PORT
- A,B = USE PORT
- T = TANK PORT
- X = EXTERNAL PILOT PORT
- Y = DRAIN PORT

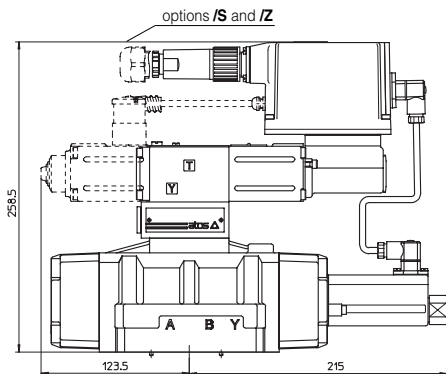

DPZO-TE-2

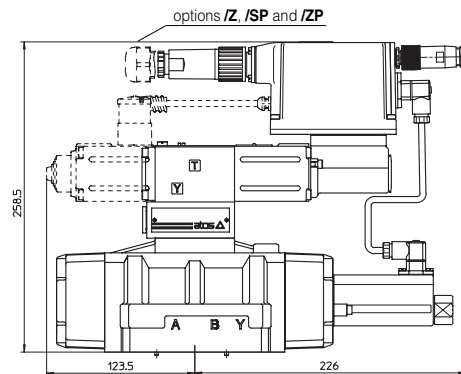

DPZO-TES*-2

Mass [kg]

	T	TE, TES
DPZO*-25*	11,9	12,3
DPZO*-27*	12,8	13,3

NOTE: For option /B the proportional solenoid and the integral electronics (in case of execution -TE and -TES) are at side of port B of the main stage. Dotted line for configuration type "7"

8 INSTALLATION DIMENSIONS FOR DPZO-3 [mm]

DPZO-3

Mounting surface - ISO 4401-AE-08-4 size 25

Fastening bolts: 6 socket head screws M12x50

Seals: 4 OR 4112; 3 OR 3056

Diameter of ports A, B, P, T: $\varnothing = 24$ mm;

Diameter of ports X, Y: $\varnothing = 7$ mm;

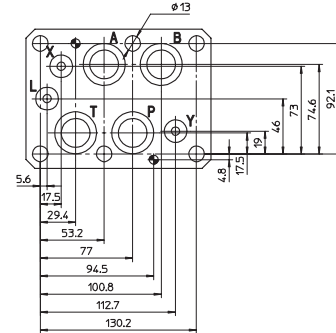
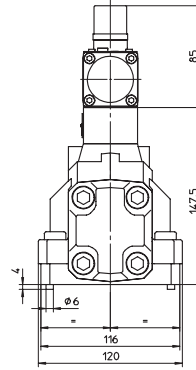
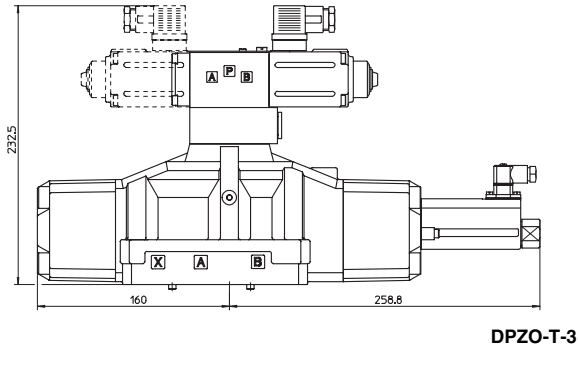

- P = PRESSURE PORT
- A,B = USE PORT
- T = TANK PORT
- X = EXTERNAL PILOT PORT
- Y = DRAIN PORT

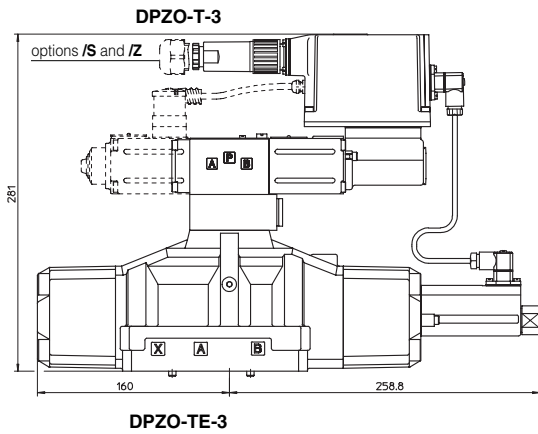

options /Z, /SP and /ZP

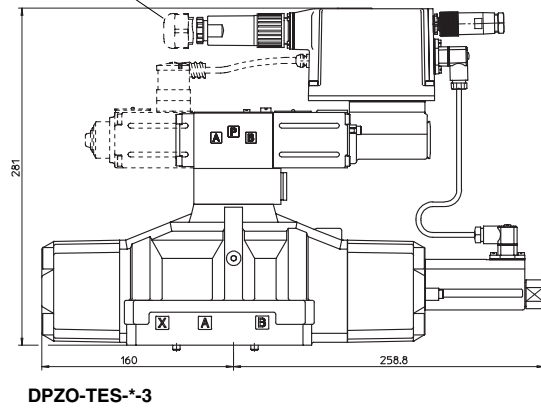

Mass [kg]

	T	TE, TES
DPZO.*-35*	17,1	17,5
DPZO.*-37*	18	18,4

NOTE: For option /B the proportional solenoid and the integral electronics (in case of execution -TE and -TES) are at side of port B of the main stage. Dotted line for configuration type "7"

9 ELECTRONIC DRIVERS FOR DPZO-T*

Valve model	-T	-TE	-TES
Drivers model	E-ME-T	E-RI-TE	E-RI-TES
Data sheet	G140	G200	G210

For complete information about the drivers characteristics and relevant options, see the technical data sheet specified in the table.

10 MOUNTING SUBPLATES FOR DPZO-1, DPZO-2, DPZO-3

Size	Model	Ports locations	Gas ports		Ø Counterbore [mm]		Mass [Kg]
			A, B, P, T	X, Y	A, B, P, T	X, Y	
10	BA-428	Ports A, B, P, T, X, Y underneath;	3/4"	1/4"	36,5	21,5	5,6
	BA-434	Ports P, T, X, Y underneath; ports A, B on lateral side	3/4"	1/4"	36,5	21,5	5,5
16	BA-418	Ports A, B, P, T, X, Y underneath;	3/4"	1/4"	36,5	21,5	3,5
	BA-519	Ports P, T, X, Y underneath; ports A, B on lateral side	1"	1/4"	46	21,5	8
25	BA-508	Ports A, B, P, T, X, Y underneath;	1"	1/4"	46	21,5	7
	BA-509	Ports P, T, X, Y underneath; ports A, B on lateral side	1"	1/4"	46	21,5	12,5