

# Proportional throttle cartridges type LIQZO-T\*, 2-way

ISO 7368 sizes from 16 to 50

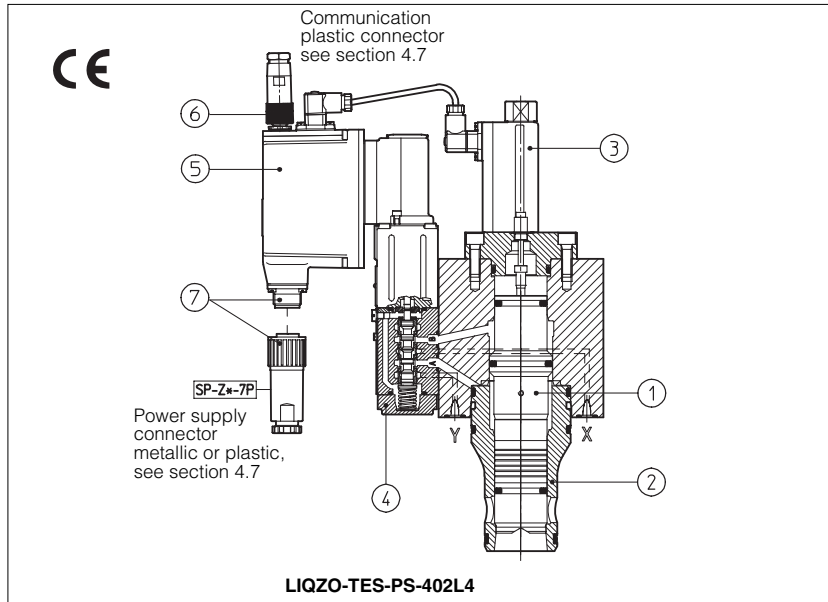

LIQZO-TE are 2-way proportional cartridge valves, designed for mounting in manifold blocks and provide proportional flow control according to the electronic reference signal.

They operate in association with electronic drivers, see section 8, which supply the proportional valves with proper current to align valve regulation to the reference signal supplied to the electronic driver.

They are available in different executions:

- T, with position transducer 3;
- TE, -TES as -T plus analogue (TE) or digital (TES) integral electronics 5.

The regulation is operated by means of a poppet 1 with double piloting area, sliding into a cartridge 2 and provided of integral LVDT position transducer 3. The poppet is controlled in closed loop by means of a proportional directional valve 4 type DHZO, see table F160.

The integral electronics 5 ensures factory presetting, fine functionality plus valve-to-valve interchangeability and simplified wiring and installation.

Following communication interfaces 6 are available for the digital -TES execution:

- PS, RS232 serial communication interface. The valve reference signal is provided with analogue commands via the 7 (or 12) pins connector 7.
  - BC, CANbus interface
  - BP, PROFIBUS-DP interface
- In the -BC and -BP interfaces the valve reference signal is provided via fieldbus; during start up or maintenance, the valves can be operated with analogue signals via the 7 (or 12) pins connector 7.

- Reduced response times and high dynamic performances.
- Typical applications: plastic injection and blow moulding, foundry and steel plants.
- ISO 7368 sizes from 16 to 50
- Max flow up to 2000 l/min with differential pressure  $\Delta p = 5$  bar, see section 2.
- Max pressure: 350 bar.

## 1 MODEL CODE

<b>LIQZO</b>	<b>- TES</b>	<b>- PS</b>	<b>- 25</b>	<b>2</b>	<b>L4</b>	<b>/ *</b>	<b>**</b>	<b>/*</b>
Flow control valve								
<b>T</b> = with position transducer <b>TE</b> = as T plus integral electronics <b>TES</b> = as T plus integral digital electronics								
Communication interfaces (only for TES) <b>PS</b> = RS232 serial <b>BC</b> = CANbus <b>BP</b> = PROFIBUS-DP								
Size: <b>16 25 32 40 50</b>								
<b>2</b> = 2 way								
							Options, see section 4: for <b>-TE</b> execution: <b>I</b> = current reference (4÷20 mA) <b>F</b> = fault signal <b>Q</b> = enable signal <b>S</b> = with logic state signals (12 poles connector) <b>Z</b> = enable, fault and monitor signals (12 poles connector) for <b>-TES</b> execution (12 poles connector): <b>Z</b> = double power supply, enable and fault	Synthetic fluids: <b>WG</b> = water-glycol <b>PE</b> = phosphate ester
							Design number	
							Regulation characteristic: <b>L4</b> = linear	

Versions with reduced flow are available on request \*2L2.

## 2 HYDRAULIC CHARACTERISTICS (based on mineral oil ISO VG 46 at 50 °C) (3)

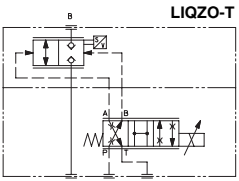
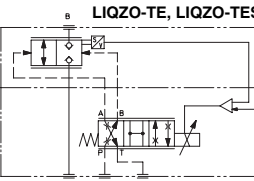
Hydraulic symbols	LIQZO-T		LIQZO-TE, LIQZO-TES		
					
Model	<b>LIQZO-T, LIQZO-TE, LIQZO-TES</b>				
Size	16	25	32	40	50
Max regulated flow at $\Delta p = 5$ bar	250	500	800	1200	2000
at $\Delta p = 10$ bar	350	700	1100	1700	2800
Maximum flow	600	1200	1800	2500	4000
Max pressure	350				
Nominal flow of pilot valve at $\Delta p = 70$ bar	15				
Leakage of pilot valve at $P = 100$ bar	1				
Response time 0 ÷ 100% step signal (1)	22	25	30	32	40
Piloting volume (2)	1,58	2,16	7,0	9,4	8,5
Hysteresis	≤ 0,1%				
Repeatability	± 0,1%				

Above performance data refer to valves coupled with Atos electronic drivers, see section 8.

(1) Response time to step signal (0% → 100%) are measured from 10% and 90% of step values with piloting pressure 140 bar and are strictly referred to valve regulation.

(2) Recommended piloting pressure is 140 ÷ 160 bar.

(3) In case of long interruption of the hydraulic supply to the pilot valve, the driver has to be switched off to avoid its overheating.

### 3 MAIN CHARACTERISTICS OF THROTTLE CARTRIDGES VALVES TYPE LIQZO-T\*

Assembly position	Any position
Subplate surface finishing	Roughness index, $\sqrt{0.4}$ flatness ratio 0,01/100 (ISO 1101)
Ambient temperature	-20°C ÷ +70°C for -T execution; -20°C ÷ +60°C for -TE and -TES
Fluid	Hydraulic oil as per DIN 51524 ... 535 for other fluids see section I
Recommended viscosity	15 ÷ 100 mm <sup>2</sup> /s at 40°C (ISO VG 15÷100)
Fluid contamination class	ISO 18/15 achieved with in line filters of 10 µm and $\beta_{10} \geq 75$ (recommended)
Fluid temperature	-20°C +60°C (standard and /WG seals) -20°C +80°C (/PE seals)

#### 3.1 Coils characteristics

Coil resistance R at 20°C	3 ÷ 3,3 Ω
Max. solenoid current	2,6 A
Max. power	35 Watt
Protection degree (CEI EN-60529)	IP65 for -T execution; IP65÷67 for -TE and -TES executions, depending to the connector type (see sect. 4.7)
Duty factor	Continuous rating (ED=100%)

### 4 INTEGRAL ELECTRONICS OPTIONS AND WIRING

- 4.1 Option /I** It provides the 4÷20 mA current reference signal and the current feedback signals instead of the standard 0÷10V. It is normally used in case of long distance between the machine control unit and the valve or where the reference signal can be affected by electrical noise. In case of breakage of the reference signal cable, the valve functioning is disabled.
- 4.2 Option /F** Safety option providing an output signal which switches to zero in case of interruption of the transducer feedback cable. In this condition the valve functioning is disabled.
- 4.3 Option /Q** Safety option providing the possibility to enable or disable the valve functioning without cutting the power supply.
- 4.4 Option /S** Option for diagnostic controls, providing three on-off output signals for the real time monitor of the valve's spool position (central, P→A or P→B), For the electrical wiring of **-TE** electronics with option **/S** (12 poles connector), see tab. G200.
- 4.5 Option /Z** For **-TE** execution: option providing the same characteristics of **/F** and **/Q** plus the monitor signal of the spool position.  
For **-TES** execution: safety option, specifically introduced for -BC and -BP communication interfaces, provides two separated electric power supplies for the digital electronic circuits and for the solenoid power supply stage. The Enable and Fault signals are also available. The option **/Z** allows to interrupt the valve functioning by cutting the solenoid power supply (e.g. for emergency, as provided by the European Norms EN954-1 for components with safety class 2), but keeping energized the digital electronic circuits, thus avoiding fault conditions of the machine fieldbus controller. For the electrical wiring, see tab. G200 and G210.

#### 4.6 Integral electronics wiring

For the electric wiring shielded cables must be provided: the shield must be connected to the power supply zero **on the generator side**, see tab. **F003**

POWER SUPPLY CONNECTOR					
PIN	SIGNAL DESCRIPTION	-TE, -TES	-TE/I	-TE/F	-TE/Q
A	Power supply 24 V <sub>dc</sub>	Stabilized:	+24V <sub>dc</sub>		
B	Power supply zero	Filtered and rectified:	V <sub>rms</sub> = 21 ÷ 33 (ripple max 2V <sub>pp</sub> )		
C	Signal zero	Reference 0 V <sub>dc</sub>	Reference 0 V <sub>dc</sub>	Reference 0 V <sub>dc</sub>	Enabling input normal working 9 ÷ 24 V <sub>dc</sub>
D	Input signal +	0 ÷ 10 V <sub>dc</sub>	4 ÷ 20 V <sub>dc</sub>	0 ÷ 10 V <sub>dc</sub>	0 ÷ 10 V
E	Input signal -				
F	Monitor	0 ÷ 10 V referred to pin C (signal 0 V <sub>dc</sub> )	4 ÷ 20 mA referred to pin C (signal 0 V <sub>dc</sub> )	Fault signal alarm = 0 V <sub>dc</sub>	0 ÷ 10 V referred to pin B (signal 0 V)
	Spool position	1 V = 10% of spool position	4 ÷ 20 mA = 0÷100% of spool position	Normal working = +24 V <sub>dc</sub>	1 V = 10% of spool position
G	Earth	Connect only when the power supply is not conform to VDE 0551 (CEI 14/6)			

COMMUNICATION CONNECTORS (for -TES)				
Communication options	-PS (RS232) male connector	-BC (CAN Bus) male connector	-BP (PROFIBUS-DP) female connector (reverse key)	
Pin number Signal description	1	NC Not Connected	CAN_SHLD Shield	+5V Termination voltage
	2	NC Not Connected	Not Connected	LINE -A Bus line (high)
	3	RS_GND Signal zero data line	CAN_GND Signal zero data line	DGND Signal zero data line / termination voltage
	4	RS_RX Valves receiving data line	CAN_H Bus line (high)	LINE-B Bus line (low)
	5	RS_TX Valves transmitting data line	CAN_L Bus line (low)	SHIELD Shield

POSITION TRANSDUCER CONNECTOR (-T)	
PIN	Signal description
1	OUTPUT SIGNAL
2	SUPPLY -15 V <sub>dc</sub>
3	SUPPLY +15 V <sub>dc</sub>
4	GND

#### Note:

- electrical signals (e.g. actual - feedback signals) acquired via valve electronics must not be used to switch off the machine safety functions. This is in accordance with the European standards (Safety requirements of fluid technology systems and components - hydraulics, EN-892).
- installation notes with basic information for commissioning and start-up, are always supplied with relevant components, together with the specific technical tables.

#### 4.7 Model codes of power supply and communication connectors

VALVE VERSION	-T		-TE, -TES		-TE/S, -TE/Z -TES/Z	-RS232 (-PS) OR CANBUS (-BC)	PROFIBUS (-BP)
	Power supply	Transducer					
CONNECTOR CODE	SP-666	SP-345	SP-ZH-7P (1)	SP-ZM-7P (1)	SP-ZH-12P (1)	SP-ZH-5P (1)	SP-ZH-5P/BP (1)
CONNECTOR CODE	IP65	IP65	IP67	IP66	IP65	IP67	IP67

(1) to be ordered separately (2) M8 connector moulded on cable 5 mt length

### 5 PROGRAMMING DEVICES

The functional parameters of the digital valves, as the bias, scale, ramp and linearization of the regulation characteristic, can be easily set and optimized with graphic interface by using the following software programming devices suitable for standard PC:

**KIT-E-SW-PS** for electronics with RS232 interface (option **-PS**)

**KIT-E-SW-BC** for electronics with CANbus interface (option **-BC**)

**KIT-E-SW-BP** for electronics with PROFIBUS-DP interface (option **-BP**)

see tab. G500 for complete information about the programming device kits and for the PC minimum requirements.

Only for the -BC and -BP communication options, the functional parameters can be alternatively set via fieldbus through the machine control unit, using the standard communication protocol implemented by Atos.

The protocol operating instructions to be implemented in the standard protocols (DS301V4.02, DSP408 for CANbus and DPVO for PROFIBUS-DP) are described in the user manuals MAN-S-BC (for -BC option) and MAN-S-BP (for -BP option) supplied with the relevant programming device kits.

**The above programming devices have to be ordered separately.**

**6 DIAGRAMS** (based on mineral oil ISO VG 46 at 50 °C)

**6.1 Regulation diagrams, see note 1**

- 1 = LIQZO-T\*-162L4
- 2 = LIQZO-T\*-252L4

**6.2 Bode diagrams**

stated at nominal hydraulic conditions

- 3 = LIQZO-T\*-162L4: 10% ↔ 90%
- 4 = LIQZO-T\*-162L4: 50% ± 5%
- 5 = LIQZO-T\*-252L4: 10% ↔ 90%
- 6 = LIQZO-T\*-252L4: 50% ± 5%

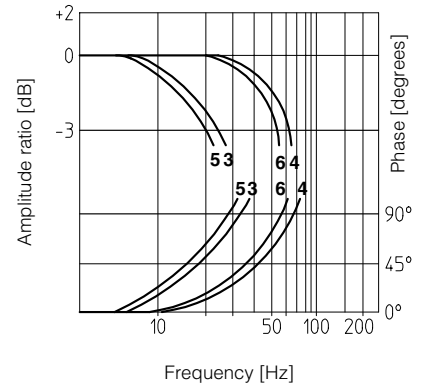
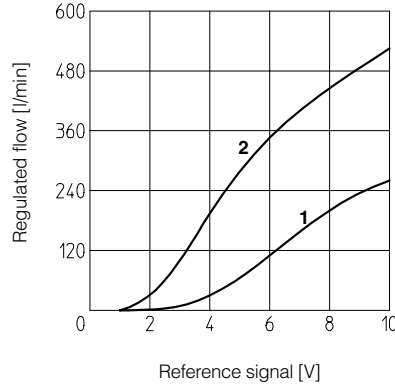

**6.3 Regulation diagrams, see note**

- 1 = LIQZO-T\*-322L4

**6.4 Bode diagrams**

stated at nominal hydraulic conditions

- 2 = LIQZO-T\*-322L4: 10% ↔ 90%
- 3 = LIQZO-T\*-322L4: 50% ± 5%

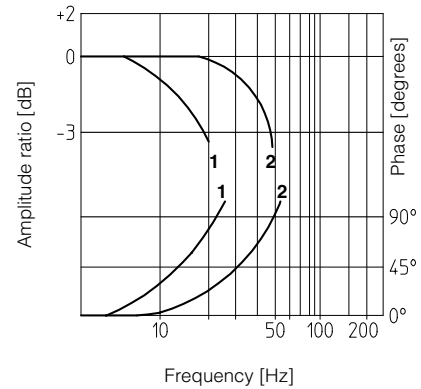
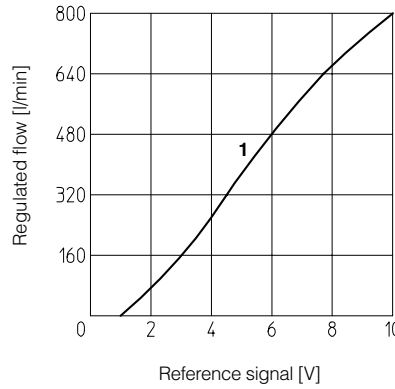

**6.5 Regulation diagrams, see note**

- 1 = LIQZO-T\*-402L4

**6.6 Bode diagrams**

stated at nominal hydraulic conditions

- 2 = LIQZO-T\*-402L4: 10% ↔ 90%
- 3 = LIQZO-T\*-402L4: 50% ± 5%

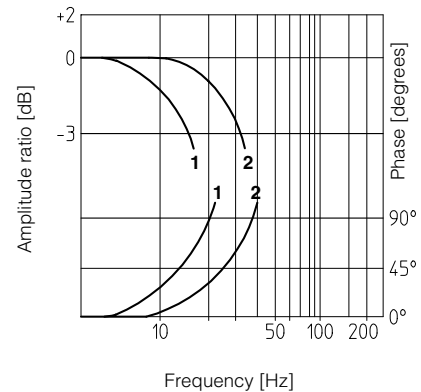
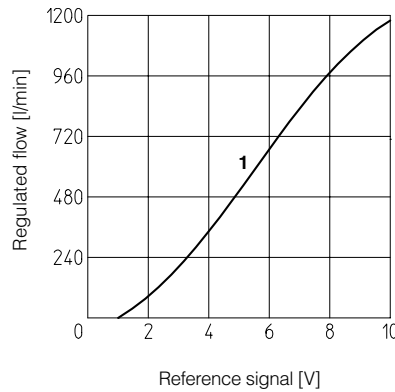

**6.7 Regulation diagrams, see note**

- 1 = LIQZO-T\*-502L4

**6.8 Bode diagrams**

stated at nominal hydraulic conditions

- 2 = LIQZO-T\*-502L4: 10% ↔ 90%
- 3 = LIQZO-T\*-502L4: 50% ± 5%

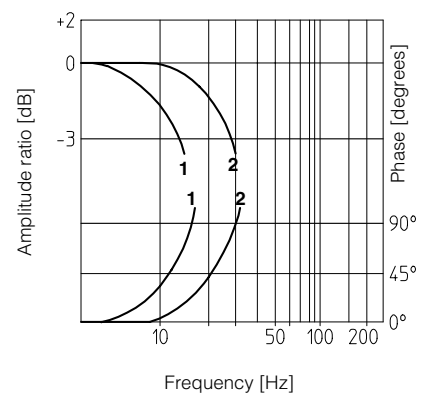
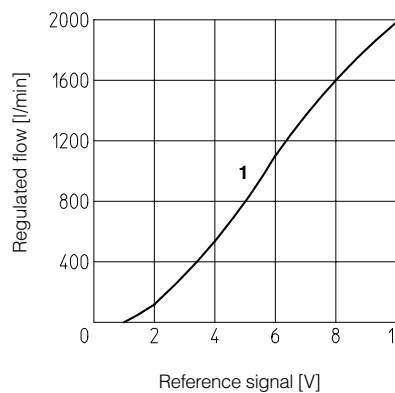

**Note:**

For the valves with digital electronics, the regulation characteristic can be modified by setting the internal software parameters, see tab. G500.

**6.9 Dynamic response**

The response times in section 2 and the frequency responses of the bode diagrams in sections 6.2, 6.4, 6.6, 6.8, have to be considered as average values. For the valves with digital electronics the dynamics performances can be optimized by setting the internal software parameters.

**7 INSTALLATION DIMENSIONS [mm]**

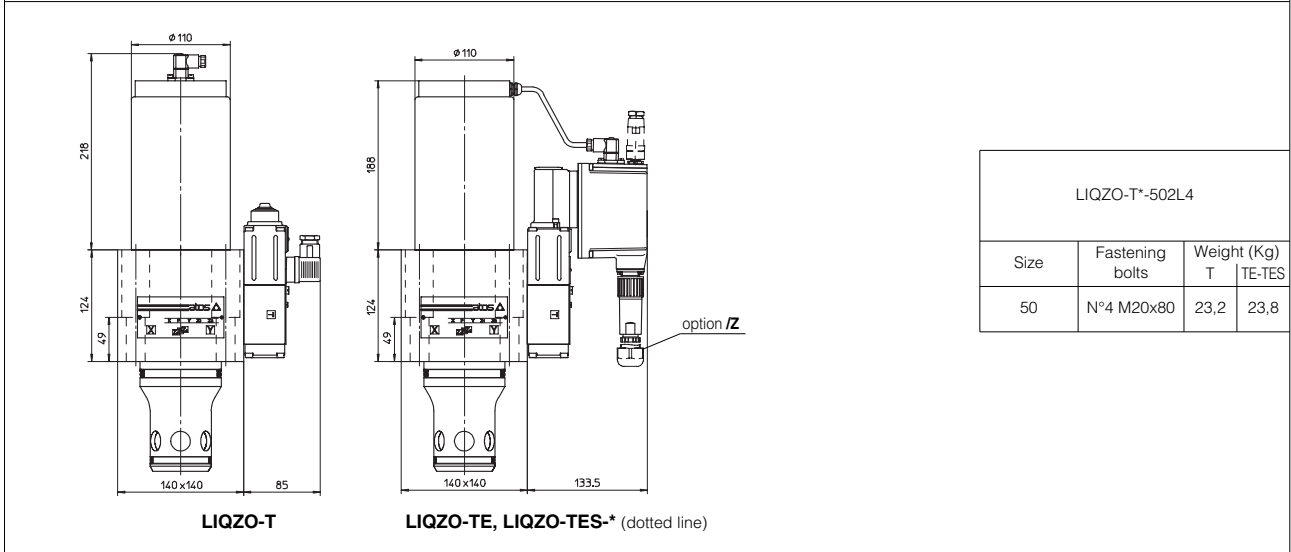
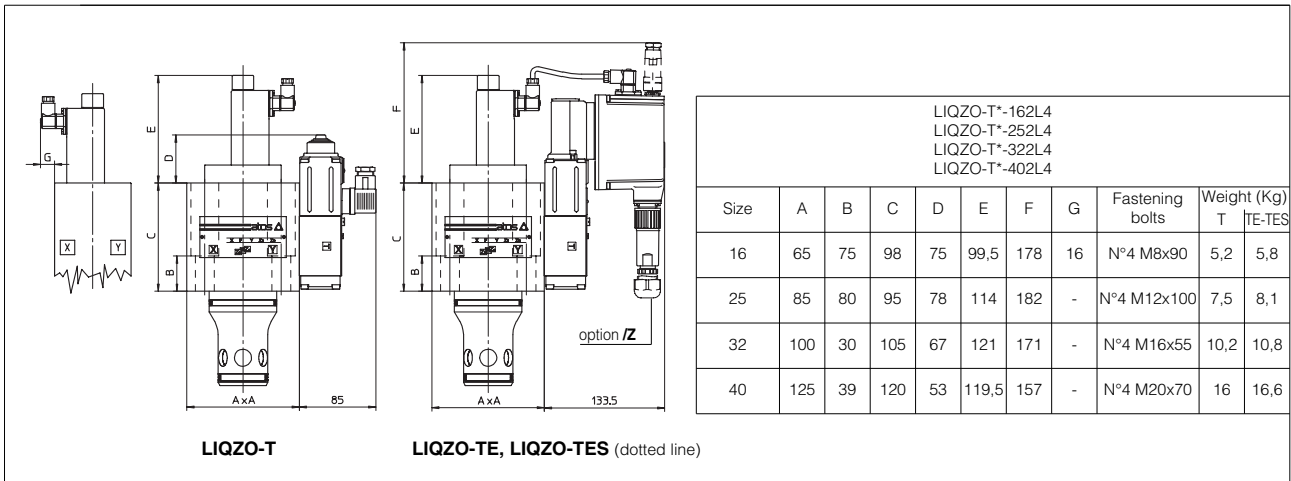

**8 ELECTRONIC DRIVERS FOR LIQZO-T\***

Valve model	-T	-TE	-TES
Drivers model	E-ME-T	E-RI-TE	E-RI-TES
Data sheet	G140	G200	G210

For complete information about the drivers characteristics and relevant options, see the technical data sheet specified in the table.

**9 COVER INTERFACE AND RECESS DIMENSIONS [mm]**

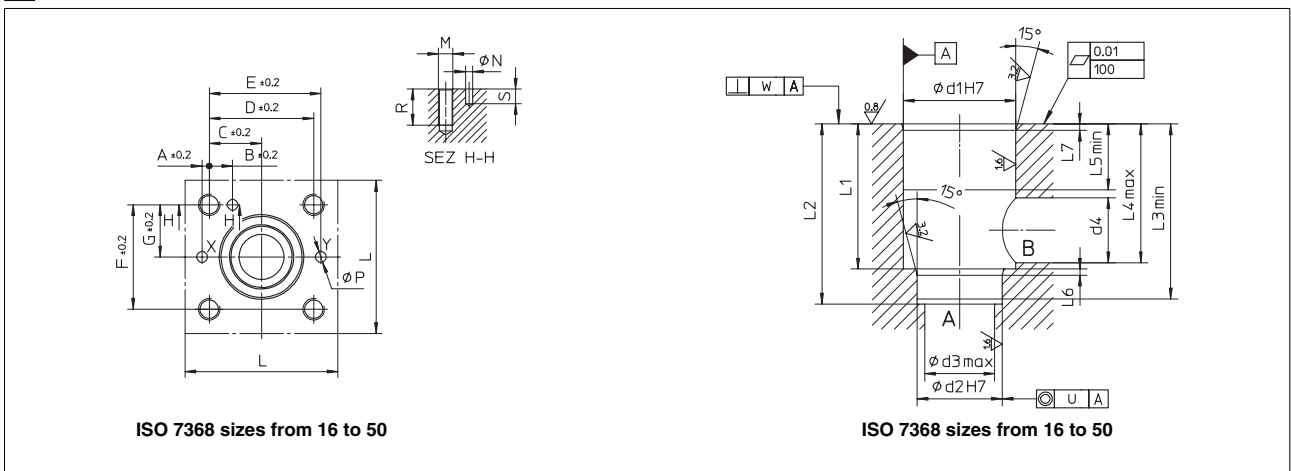

Size	COVER INTERFACE													RECESS												
	A	B	C	D	E	F	G	L	M	ØN	P <sub>max</sub>	R	S <sub>min</sub>	ød1	ød2	ød3	ød4	L1	L2	L3	L4	L5	L6	L7	U	W
16	2	12,5	23	46	48	46	23	65	M8	4	4	20	6	32	25	16	16	43 <sup>+0,1</sup> <sub>0</sub>	56 <sup>+0,1</sup> <sub>0</sub>	54	42,5	20	2	2	0,03	0,05
25	4	13	29	58	62	58	29	85	M12	6	6	30	8	45	34	25	25	58 <sup>+0,1</sup> <sub>0</sub>	72 <sup>+0,1</sup> <sub>0</sub>	70	57	30	2,5	2,5	0,03	0,05
32	6	18	35	70	76	70	35	102	M16	6	8	38	8	60	45	32	32	70 <sup>+0,1</sup> <sub>0</sub>	86 <sup>+0,1</sup> <sub>0</sub>	83	68,5	30	2,5	2,5	0,03	0,1
40	7,5	19,5	42,5	85	92,5	85	42,5	125	M20	6	10	46	8	75	55	40	40	87 <sup>+0,1</sup> <sub>0</sub>	105 <sup>+0,1</sup> <sub>0</sub>	102	84,5	30	3	3	0,05	0,1
50	8	20	50	100	108	100	50	140	M20	8	10	46	8	90	68	50	50	100 <sup>+0,1</sup> <sub>0</sub>	122 <sup>+0,1</sup> <sub>0</sub>	117	97,5	35	3	4	0,05	0,1