

Electronic drivers type E-ME-AC

Eurocard format, for single and double solenoid proportional valves without transducer

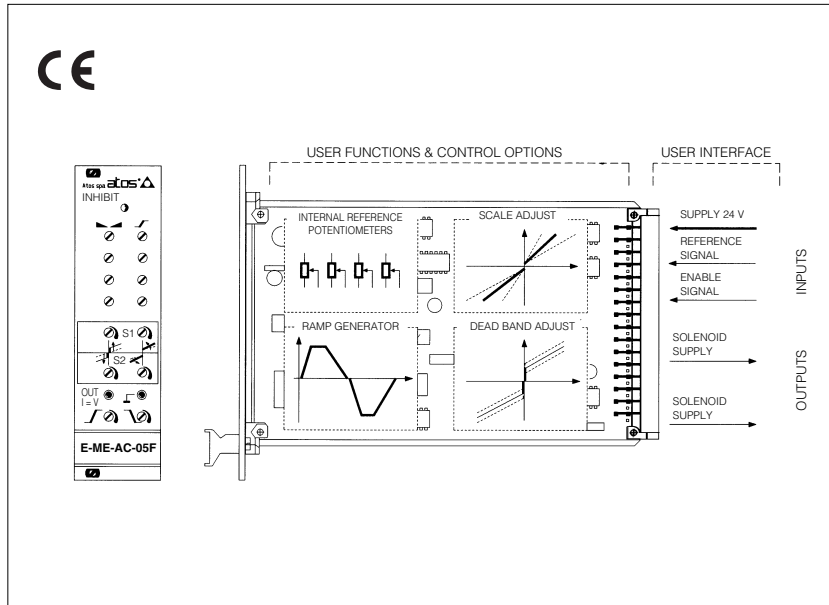

E-ME-AC electronic drivers supply single or double solenoid proportional valves type ZO(R)-A with the correct current signal to align valve regulation to the reference signal.

They are designed to work in open or closed-loop systems according to the block diagram 2.

In closed loop systems, E-ME-AC driver can be coupled to commercial axes card according to the block diagram 2.

The driver operates the valve's regulation proportionally to the input reference signal (voltage or current) supplying a switching current to the solenoid. Scale and Bias adjustments, for accurate valve regulations, are available.

The driver is normally used with a reference signal supplied by an external set-point potentiometer or by PLC control unit and a symmetrical rising and falling ramp generator.

This driver is supplied already set, coupled with the suitable proportional valve, optimising its regulation.

The electronic card is in Eurocard format (DIN 41494 - Plug-in units).

This new version includes the following improved features:

- electronic filters on input and output lines;
- CE marking granting the conformity to the EMC Directive (Electromagnetic Compatibility);
- both sides of the card with shielded cover with PE faston connector.

1 MODEL CODE

E-ME - **AC** - **01F** - ****** **/***

E-ME = Electronic driver in Eurocard format

AC = Control type: for open loop and closed loop applications

01F = for single solenoid proportional valves
05F = for double solenoid proportional valves

Set code (see 4.3)

Design number

Options:

- = standard symmetrical ramp
- /RR** = with adjustable dissymmetrical ramps
- 4** = with 4 reference potentiometers
- /RR-4** = with rising and falling ramps and 4 reference potentiometers
- /4R-4** = with 4 ramps and 4 reference potentiometers
- /I** = suitable to receive current reference signal 4±20 mA

2 BLOCK DIAGRAM

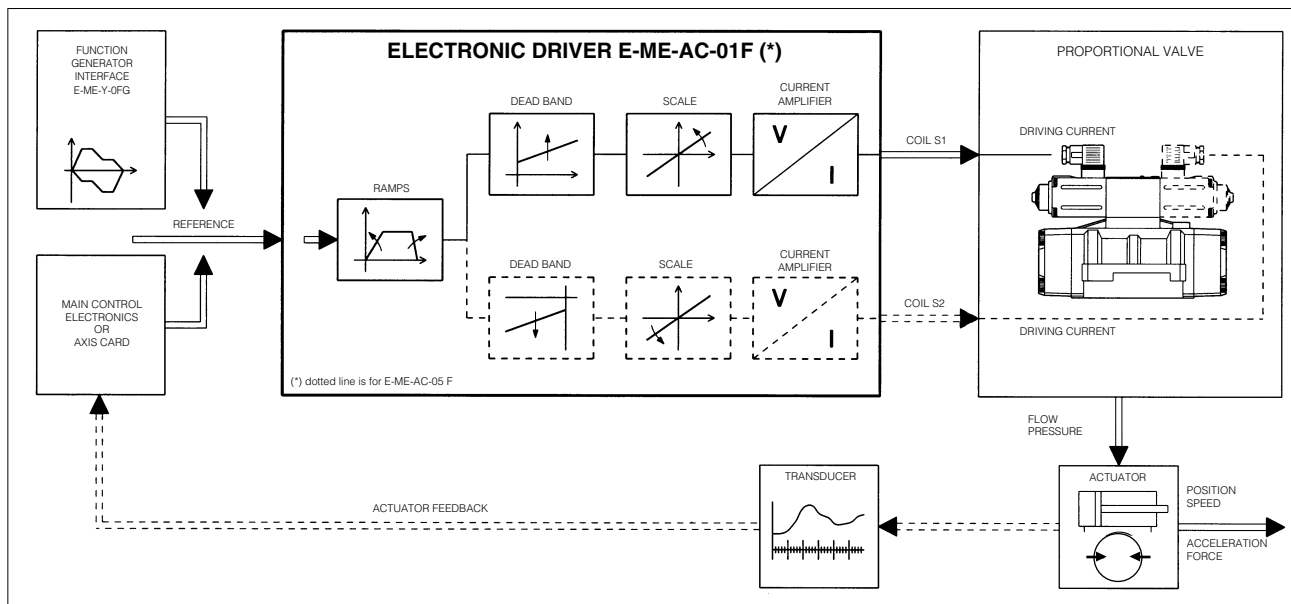

3 MAIN CHARACTERISTICS OF E-ME-AC ELECTRONIC DRIVERS

Power supply (positive at contacts 2a, 2c) (negative at contacts 4a, 4c)	Nominal: :24V _{DC} Rectified & filtered: :V _{RMS} = 21 ÷ 33 (max ripple = 2Vpp)
Max power consumption	50 W
Current supplied to solenoid	I _{max} = 3.3A square wave PWM type; (for ex-proof valves I _{max} = 2,5 A)
Nominal reference signal, factory preset	E-ME-AC-01F: 0 ÷ +5V at contact 12c (GND on 8a) E-ME-AC-05F: ± 5V at contact 12c (GND on 8a) 4 ÷ 20 mA for /I: at contacts 12c (+) and 8a (-)
Reference signal variation range (Scale adjust)	± 10V max ± 2,5V min
Input signal impedance	Voltage signal R _i > 50 KOhm - (/I option R _i = 316 Ohm)
Potentiometers supply	+5V / 50 mA at contact 10c and -5V / 20mA at contact 14c
Ramp time	5 sec. max (0 ÷ 100% of reference signal)
Enabling signal	V = 5 ÷ 24V _{DC} on contact 18a with led indicator on panel
Electrical wiring	Coil : 2 x 1 mm ² to 20 m 2 x 1,5 mm ² shielded to 40 mt
Card format	Europe 100x160 mm (Plug-in unit DIN 41494)
Card connector	Male DIN 41612 /D
Connector elements available	Type E-K-32M frame snap connector (see table G800) To be ordered separately
Operating temperature	0 ÷ 50°C (storage -20° ÷ +70°C)
Front panel dimensions	128,4 x 35,3 mm
Weight	540 g
Features	Rapid solenoid excitation and switching off. Outputs to solenoids protected against accidental short circuits

4 GENERAL SPECIFICATIONS

4.1 Power supply and wirings

The power supply must be appropriately stabilized or rectified and filtered. If the power supply is generated by a single phase rectifier, use a 10000 µF/40V capacitor; if pulse voltage is generated by a three phase rectifier, connect a 4700 µF/40V capacitor (see [11] Wiring block diagram). It is always recommended to use shielded cables with earthed shield for connections to the reference generators.

4.2 Reference signal

The electronic driver is designed to receive voltage or current reference signals according to the following options:

- Internal potentiometers mounted on board, see [11] Wiring block diagram.
- External reference signals, see [5].

Note that drivers designed to receive current reference (options /I) have signal values in the range 4 to 20 mA and do not have mounted on board potentiometer option.

It is possible to use current option also for double channels drivers type E-ME-AC-05F using the reference inversion signal on contact 18c (5 ÷ 24 V_{DC}).

4.3 Set code

Basic calibration of the electronic driver is factory preset according to the proportional valve it has to be coupled with. These pre-calibrations are identified by a standard number in the model code as follows:

- | | |
|---------------------|--------------------------|
| 1 = RZGO, KZGO | 2 = RZMO, AG*ZO, LI*ZO |
| 3 = DHZO, DKZOR | 4 = DPZO-A-*5, DPZO-A-*7 |
| 6 = QV*ZO(R), LIQZO | |

For ex-proof valves, insert an "A" before the code of adjustment.

For example, the code of adjustment for RZGA is A1. See table E120

4.4 Calibrations/settings available to the user, see [7], [8], [9], [10].

- Scale

The relation between driving current and reference signal can be regulated with the Scale adjustment. For single solenoid valves with two external operating positions, the reference signal is the same as the double solenoid driver.

Separate Scale potentiometers for solenoids S1 and S2 enable the electronic card to be set for different output currents, obtaining differential hydraulic operations.

- Bias (dead band)

Regulation of dead band adjusts the hydraulic zero of the valve (starting position adjustment) to the corresponding electrical zero. The electronic card is factory preset for the valve it is coupled with according to the set code (see section 4.3). E-ME-AC-05F/* driver for double solenoid valve are equipped with an internal channel selector enabling the relevant channel when input reference voltage signal is greater than ± 100 mV, enabling start current set by front panel Bias potentiometers P5 and P6 for independent solenoid Dead Band regulation.

- Ramps, see [7], [11], [12]

The internal ramp generator circuit converts a step input signal into a slowly increasing output signal, (solenoid current).

The rise/fall time of the current is set via potentiometers on front panel up to a maximum time of 5 sec for 0 - 100% of reference signal. Option /RR allows use of dissymmetrical ramps, /4R-4 allows the driver to regulate 4 different ramps,

5 EXTERNAL REFERENCE SIGNALS

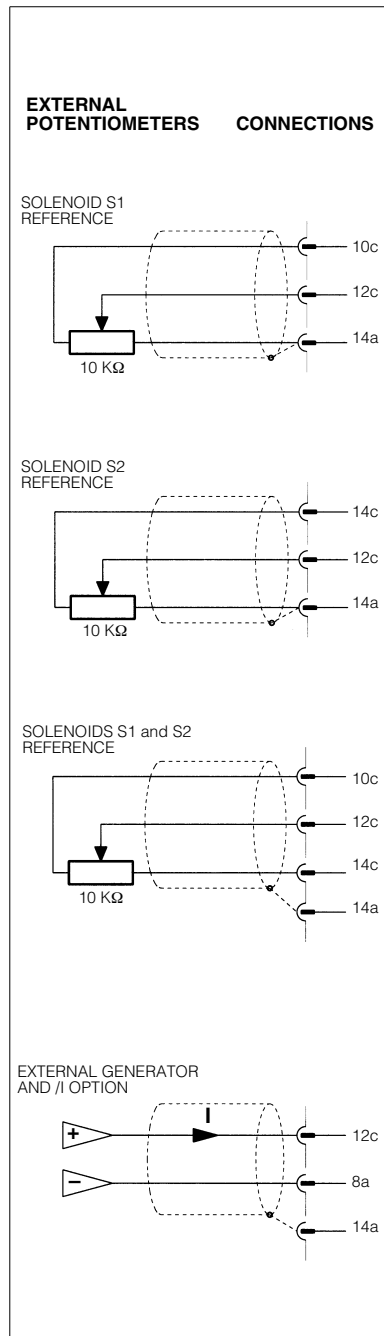

each one connected to respective reference potentiometer on front panel.
To switch off the ramp circuit connect contacts 6c and 6a on the electric connector. To set external ramp option set the switch SW1 in position 2 as shown in [7].

6 INSTALLATION AND START-UP

It is advisable to perform calibration procedures in the order given below.

6.1 Warning

- Never insert or remove the driver while the electronic system is powered on.
- Voltages must always be measured with reference to GND (connector contact 8a or front panel test point \underline{r}).
- Refer to [8]. Topographical view to identify components mentioned in calibration procedures.

6.2 Start-up

Factory pre-set adjustments might not meet the desired requirements for the specific application and performances can be optimized by on-site re-adjustments of Bias, scale and ramps potentiometers, in sequence.

- Connect the electronic driver according to the desired connection diagram, [11], [12].

The current supplied to the coil can be measured by a voltmeter connected between the test points on the front panel.

For E-ME-AC-05F the channel enabled led (L5 or L6) shows the supplied coil.

- **Enabling signal**, see [11]

The electronic driver operate when the contact 18a is supplied with an enabling signal (usually 24V_{DC}). It could be useful in emergency conditions to inhibit the driver by zeroing this signal.

- **Bias adjustment** (Dead band compensation), see [8], [9], [10].
- Supply a reference signal voltage (0V_{DC} for E-ME-AC-01F and $\pm 0,1V_{DC}$ for E-ME-AC-05F).
Gradually turn bias potentiometer(s) until a movement of the controlled actuator is obtained
- Turn in the opposite direction until the actuator is stopped.

- **Scale adjustment**, see [8], [9], [10].

Supply max reference voltage signal (for E-ME-AC-05F driver repeat for max negative voltage) in the specified range and turn scale potentiometer(s) until the actuator speed reaches the desired value.

- **Ramps**, see [7], [8]

Turning the ramp potentiometer(s) clockwise, acceleration(s) and deceleration(s) can be reduced to obtain optimization of the complete system.

7 RAMPS AND SETTINGS

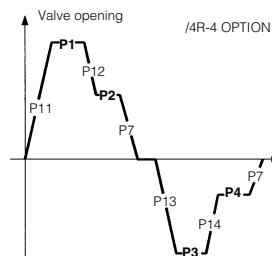
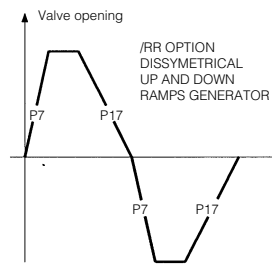

EXTERNAL RAMP SETTING

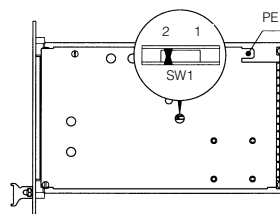

EXTERNALLY RAMP POTENTIOMETER

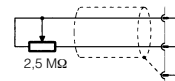

8 E-ME-AC-05F TOPOGRAPHICAL VIEW OF REGULATIONS

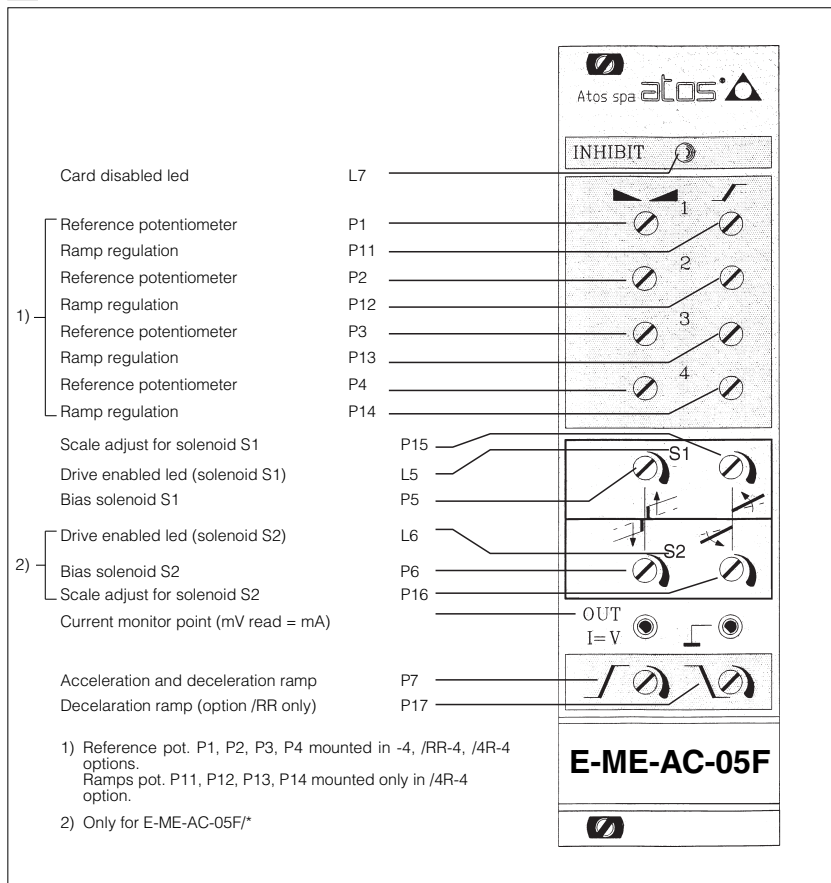

9 E-ME-AC-01F ADJUSTMENT

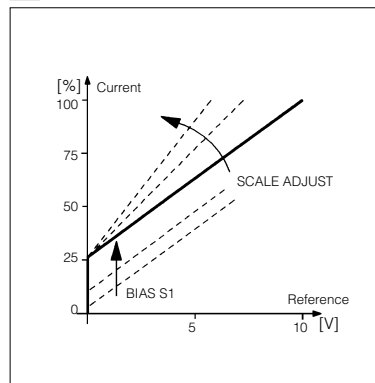

10 E-ME-AC-05F ADJUSTMENT

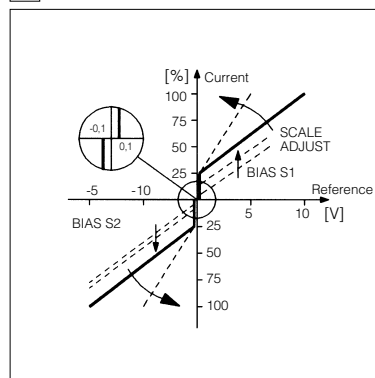

11 WIRING BLOCK DIAGRAM

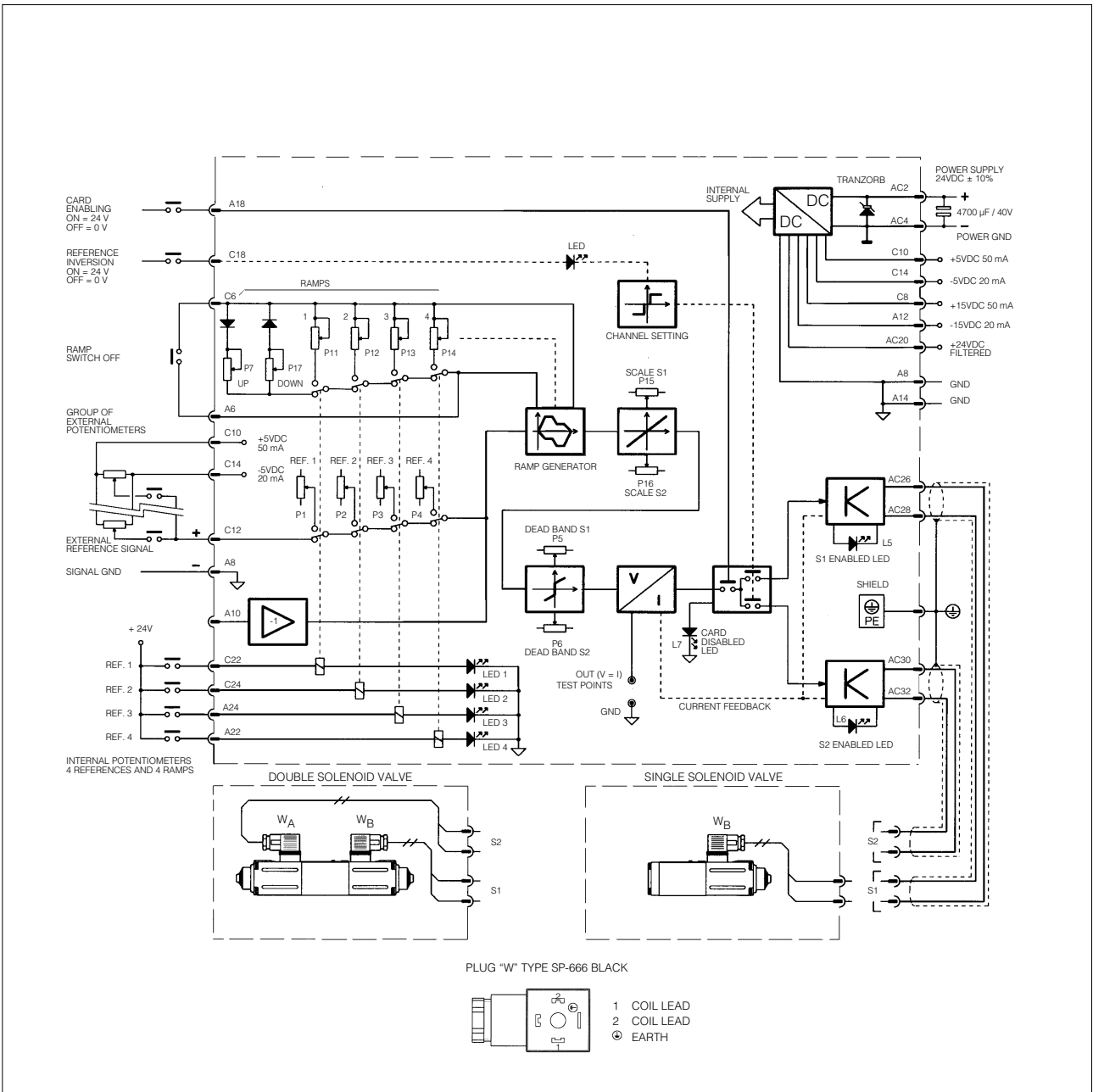

12 GENERAL CONNECTIONS

