

# Integral electronic drivers type E-RI-AES

digital, for proportional valves without transducer

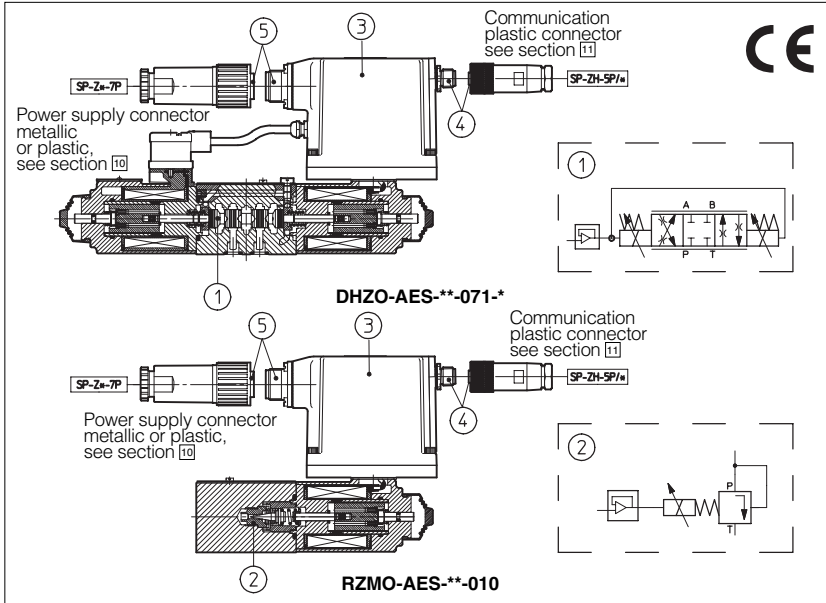

These digital drivers are integral to Atos proportional valves without pressure or position transducer, and they control the current to the solenoid, regulating the spool position ①, the flow or the pressure ② according to the electronic reference signal.

### Features

- Integral digital electronics ③, factory preset
- Software setting of the main functional parameters as bias, scale, ramps, by means of the relevant programming devices KIT-E-SW-\*, see section ⑧
- Possibility to optimize the application performances modifying via software the internal parameters as the regulation characteristic of the valve (linearization)
- Standard execution with 7 poles power supply connector, see section ②
- 12 poles power supply connector for safety option /Z, see section ③.

Following communication interfaces ④ are available:

- -PS, RS232 serial communication interface. The valve reference signal is provided with analogue commands via the 7 (or 12) pins connector ⑤
  - -BC, CANbus interface
  - -BP, PROFIBUS-DP interface
- In the -BC and -BP interfaces the valve reference signal is provided via fieldbus; during start up or maintenance, the valves can be operated with analogue signals via the 7 (or 12) pins connector ⑤.
- IP67 protection degree.
  - 3,3A maximum current to the coils.
  - CE marking grants the conformity to the EMC Directive (Electromagnetic Compatibility).

## 1 MODEL CODE: PROPORTIONAL VALVES WITH INTEGRAL DIGITAL DRIVERS TYPE E-RI-AES

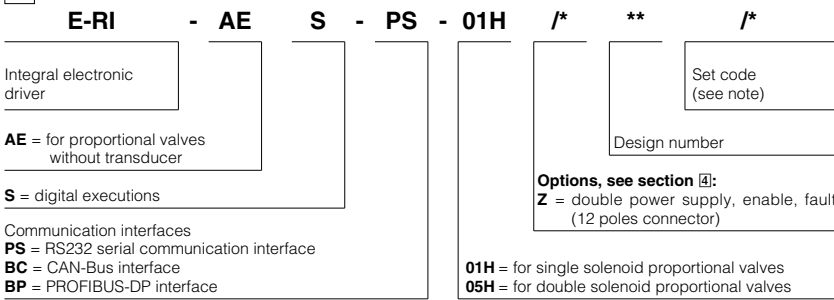

## 2 ELECTRONIC AND WIRING BLOCK DIAGRAM FOR -AES (7 POLES CONNECTOR)

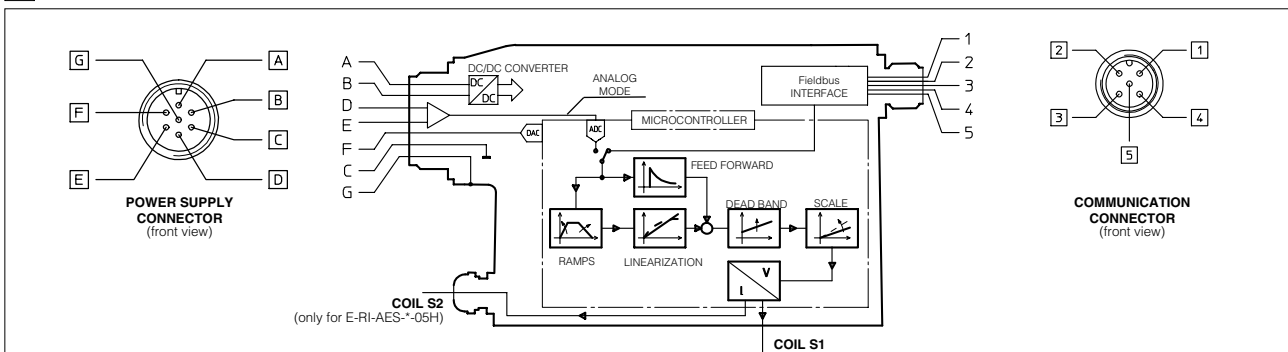

**Note:** with -BC and -BP options, the connections D-E-F can be used to operate the valve with analogue signals during start-up or maintenance

POWER SUPPLY CONNECTOR			COMMUNICATION CONNECTOR				
PIN	SIGNAL DESCRIPTION	TECHNICAL SPECIFICATION	Communication options	-PS (RS232) Male connector	-BC (CAN-Bus) Female connector (reverse key)	-BP (PROFIBUS-DP) Female connector (reverse key)	
A	Power supply 24 V <sub>DC</sub>	Stabilized: +24V <sub>DC</sub>	Pin number Signal description	1	CAN_SHLD	+5V	
B	Power supply zero	Filtered and rectified: V <sub>max</sub> = 21 ÷ 33 (ripple max 2 V <sub>pp</sub> )		2	NC	Shield	Termination voltage
C	Signal zero	Reference 0 V <sub>DC</sub>		3	NC	NC	LINE -A
D	Input +	0 ÷ 10V <sub>DC</sub> (for single solenoid valve)		4	RS_RX	CAN_GND	Bus-line (high signal)
E	Input -	± 10V <sub>DC</sub> (for double solenoid valve)		5	Signal zero data line	Signal zero data line	DGND - Signal zero data line - Termination voltage
F	Monitor (driving current)	0 ÷ 5 V (for single solenoid valve) ± 5 V / 1 V = 1A (for double solenoid valve)			RS_TX	CAN_H	LINE-B
G	Earth	Connect only when the power supply doesn't conform to VDE 0551 (CEI 14/6)			Valves receiving data line	Bus-line (high signal)	Bus-line (low signal)
				Valves transmitting data line	CAN_L	SHIELD	
					Bus-line (low signal)	Shield	

### 3 ELECTRONIC AND WIRING BLOCK DIAGRAM FOR -AES/Z (12 POLES CONNECTOR)

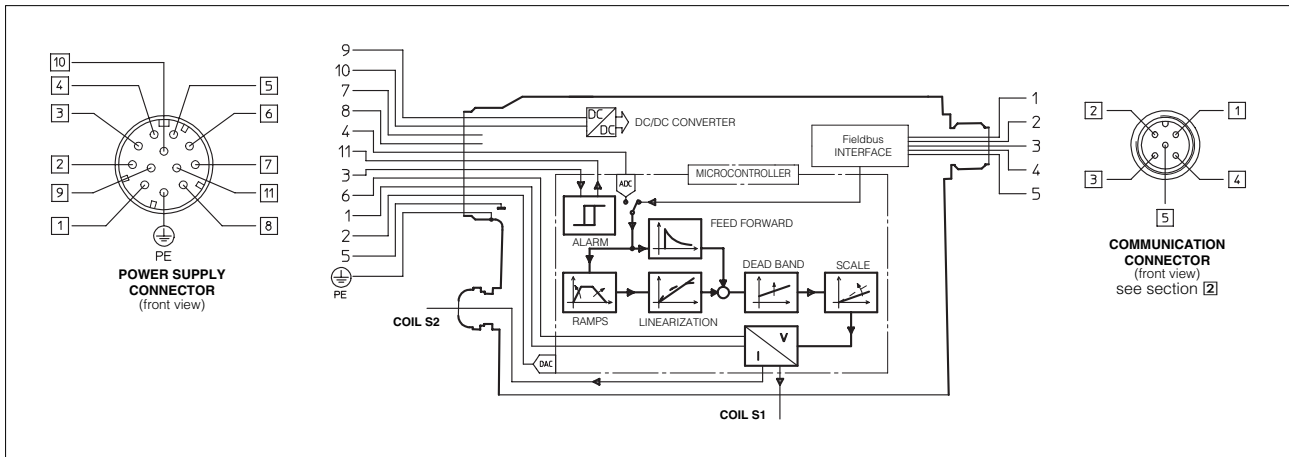

**POWER SUPPLY CONNECTOR (OPTION /Z)**

PIN	SIGNAL DESCRIPTION	TECHNICAL SPECIFICATION
1	Power supply 24 V <sub>DC</sub> (power stage)	Stabilized: +24 V <sub>DC</sub>
2	Power supply 0 V <sub>DC</sub> (power stage)	Filtered and rectified: V <sub>rms</sub> 21-33 (ripple max 2 V <sub>pp</sub> )
3	Enable	Enabling input - normal working 24 V <sub>DC</sub>
4	Input signal +	0 ÷ 10 V <sub>DC</sub> (for single solenoid valve) ± 10 V <sub>DC</sub> (for double solenoid valve)
5	Signal zero	Reference 0 V <sub>DC</sub>
6	Monitor (driving current)	± 5 V <sub>DC</sub> referred to pin 5 1V = 1A
7	NC	Not connected
8	NC	Not connected
9	Power supply 24 V <sub>DC</sub> (logic stage)	Stabilized: +24 V <sub>DC</sub>
10	Power supply 0 V <sub>DC</sub> (logic stage)	Filtered and rectified: V <sub>rms</sub> 21-33 (ripple max 2 V <sub>pp</sub> )
11	Fault	Alarm = 0 V <sub>DC</sub> Normal working = +24 V <sub>DC</sub>
PE	Earth	Connect only when the power supply doesn't conform to VDE 0551 (CEI 14/6)

### 4 OPTIONS

#### 4.1 Option /Z (12 poles connector)

Safety option, specifically introduced for -BC and -BP communication interfaces, provides two separated electric power supplies for the digital electronic circuits and for the solenoid power supply stage. The Enable and Fault signals are also available.

##### - Double power supply - Pin 1, 2 / 9, 10

The double power supply allows to interrupt the valve functioning by cutting the solenoid power supply (pins 1 and 2) e.g. for emergency, as provided by the European Norms EN954-1 for components with safety class 2, but keeping energized the digital electronic circuits (pins 9 and 10), thus avoiding fault conditions of the machine fieldbus controller.

Pins 2 and 10 (zero Volt) are connected together inside the electronics.

##### - Enable signal - Pin 3

Safety function providing the possibility to enable or disable the valve functioning without cutting the power supply. This is particularly useful when the valve functioning has to be disabled regularly during the machine cycle. Removing the enable command, it is possible to inhibit the valve driver, with the consequent interruption of the valve operations. The driver is active with an enabling signal +9 to +24V<sub>DC</sub>.

##### - Fault signal - Pin 11

Safety function providing an output signal which switches to zero in case of alarm conditions as electronic overcurrent and overtemperature. In this condition the valve functioning is disabled.

## 5 MAIN CHARACTERISTICS OF DIGITAL INTEGRAL ELECTRONIC DRIVERS

<b>Driver section</b>			
Format	Sealed box on the valve - Protection: IP67 DIN 40050 - Insulation: VDE0110		
Electromagnetic compatibility (EMC)	Emission: EN 50081-2 - Immunity: EN 50082-2		
Max power consumption	50 W		
Current supplied to solenoid	I <sub>max</sub> = 3.3 A square wave PWM type		
Analog input signal impedance	Voltage signal R <sub>i</sub> > 50KΩ		
Operating temperature	-20°C ÷ +60°C (storage -20°C ÷ +70°C)		
Alarm messages	Electronic overcurrent and overtemperature		
Communication options	<b>RS232 interface (option -PS)</b>	<b>CAN-Bus interface (option -BC)</b>	<b>Profibus-DP interface (option -BP)</b>
Serial input format	RS232C serial connection	Industrial field-bus with optical insulation type CAN-Bus ISO 11898	Industrial field-bus with optical type PROFIBUS - DP European fieldbus standard EN 50170 part 2
Communication Protocol	Atos protocol with ASCII coding	CANopen EN50325-4 Device Profile DS408	PROFIBUS - DP EN50170-2 IEC61158
Programming interface - see section 8	Software interface (see tab. G500)	Master CAN-Bus device	Master PROFIBUS device

**Note:** A minimum time of 300 to 500 ms have be considered between the driver energizing with the 24 Vdc power supply and when the valve is ready to operate. During this time the current to the valve coils is switched to zero.

## 6 AVAILABLE SETTINGS

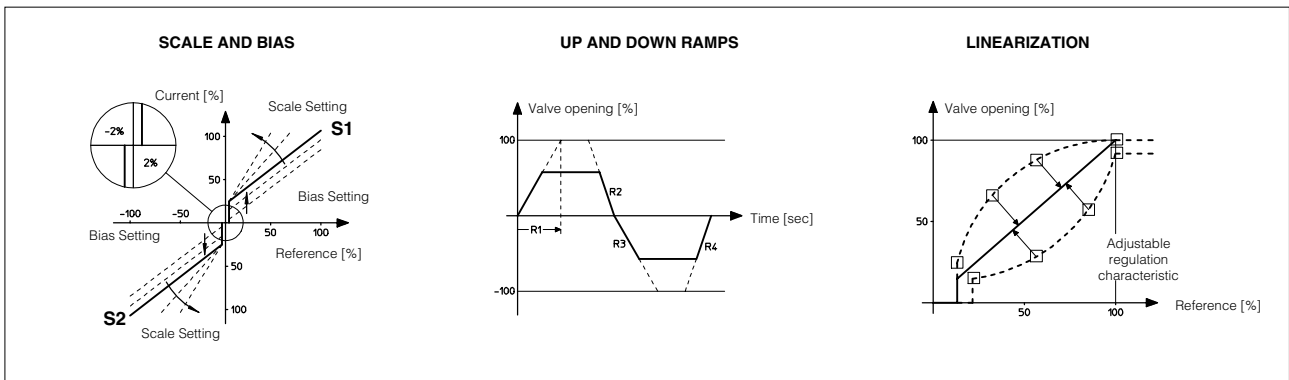

In addition to the above settings, other software regulations are available:

- Customized configuration of the reference signal, instead of standard  $\pm 10V$
- Internal static generation of the reference signal. This function is particularly useful during start-up or maintenance
- Dither frequency
- Alarm setting of the high/low limits of the electronics temperature

## 7 DIMENSIONS OF THE ELECTRONIC DRIVER AND CONNECTORS [mm]

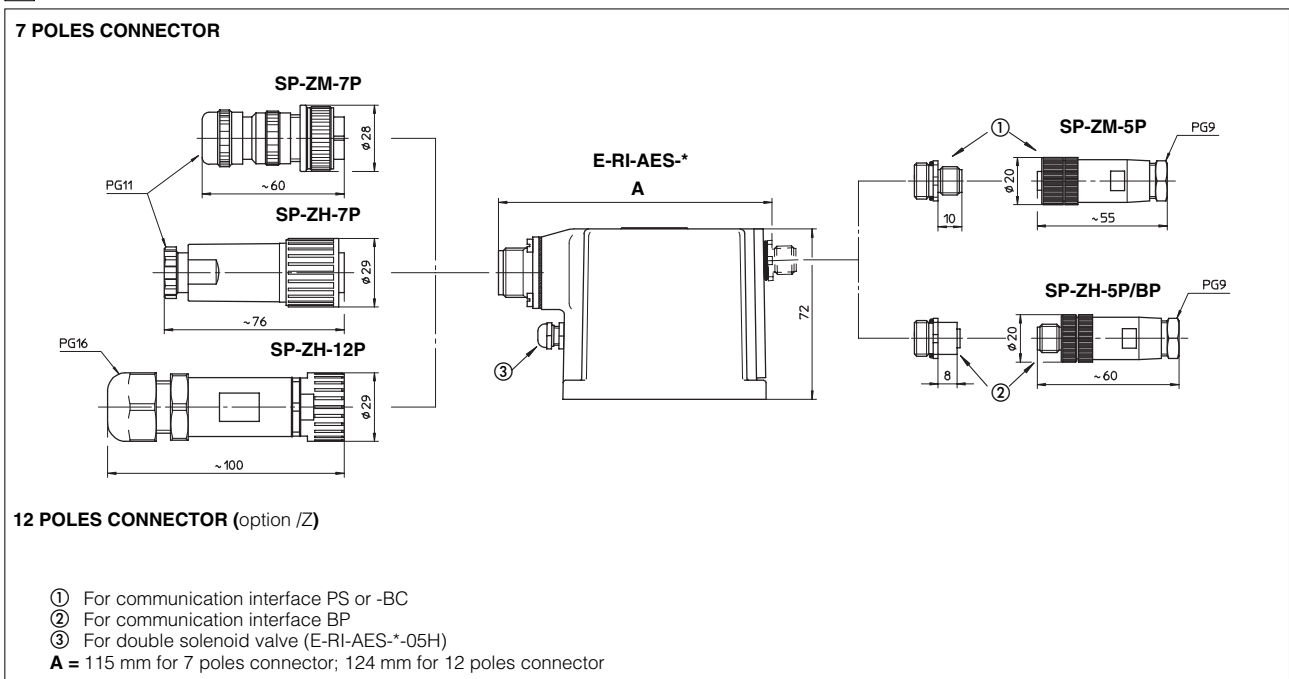

## 8 PROGRAMMING DEVICES

The functional parameters of the digital valves, as the bias, scale, ramp and linearization of the regulation characteristic, can be easily set and optimized with graphic interface by using the following software programming devices suitable for standard PC:

**KIT-E-SW-PS** for electronics with RS232 interface (option **-PS**)

**KIT-E-SW-BC** for electronics with CANbus interface (option **-BC**)

**KIT-E-SW-BP** for electronics with PROFIBUS-DP interface (option **-BP**)

see tab. G500 for complete information about the programming device kits and for the PC minimum requirements.

Only for the **-BC** and **-BP** communication options, the functional parameters can be alternatively set via fieldbus through the machine control unit, using the standard communication protocols implemented by Atos.

The protocol operating instructions to be implemented in the standard protocols (DS301V4.02, DSP408 for CANbus and DPVO for PROFIBUS-DP) are described in the user manuals MAN-S-BC (for **-BC** option) and MAN-S-BP (for **-BP** option) supplied with the relevant programming device kits.

**The above programming devices have to be ordered separately.**

## 9 FIELDBUS FEATURES

### 9.1 CANbus - CANopen features implemented in Atos protocol

Protocol	CANopen version DS301 V4.02
Network error ctrl	Node Guarding
Boot up process	Minimum boot-up
Node ID, Baudrate	setting via LSS (Layer Setting Services) and via SDO
Number of RPDO	Two Receive PDOs
Number of TPDO	Two Transmit PDOs
Number of SDO	One Receive SDO and one Transmit SDO
Device Profile	DSP408 Device Profile Fluid Power Technology
Configuration	Physical Layer: ISO11898 (transmission rates from 10 Kbit/s to 1 Mbit/s) Data Link Layer: Based on CAN standard frame with 11-bit identifier (CAN 2.0A)
Info (file)	EDS file (Electronic Device Data Sheet) enclosed in a CD-ROM (Kit-E-SW-BC) with the proper manual

### 9.2 Profibus DP features implemented in Atos protocol

Protocol	Profibus version DPV0
Error control	SAP 60
Boot up proces	SAP 61, SAP 62
Node ID	SAP 55 or dip-switches hardware
Cyclic and Acyclic communication	PPO Telegrams: Type 3 for real-time and parameter communication (string management is realized with an Atos algorithm, see Kit-MAN-S-BP) - processed data area (PZD) of PPO telegram is mappable.
Device profile	PROFIBUS Profile: Fluid Power Technology
Configuration	Physical Layer: (lev.1 - EN50170 part. 2) rates from 9,6 Kbit/s to 12 Mbit/s, up to 126 stations (with repeaters) Data Link Layer: (lev.2 - EN50170 part3/4)
Info (file)	GSD file (Electronic Device Data Sheet) enclosed in a CD-ROM (Kit-E-SW-BP) with the proper manual

## 10 CHARACTERISTICS OF POWER SUPPLY CONNECTORS (to be ordered separately)

CONNECTOR TYPE	POWER SUPPLY CONNECTOR		
	SP-ZH-7P	SP-ZM-7P	SP-ZH-12P
CODE	Female straight circular socket plug 7 pins		
TYPE	Female straight circular socket plug 11 pins + PE		
MATERIAL	Plastic reinforced with fiber glass	Aluminium alloy with cadmium plating	Plastic reinforced with fiber glass
CABLE GLAND	PG11		PG16
CABLE	LiYCY 7x 0.75 mm <sup>2</sup> max 20m 7 x 1 mm <sup>2</sup> max 40m		LiCY 10 x 0,14 mm <sup>2</sup> (signal) LiYY 3 x 1 mm <sup>2</sup> (alimentation)
CONNECTION TYPE	to solder		to crimp
STANDARD	DIN 43563-BF6-3-PG11	Secondo MIL-C-5015 G	DIN 43563
PROTECTION (DIN 40050)	IP 67	IP 66	IP 65

## 11 CHARACTERISTICS OF COMMUNICATION CONNECTORS (to be ordered separately)

CONNECTOR TYPE	RS232 CONNECTOR (-PS) or CAN-Bus (-BC)	PROFIBUS CONNECTOR (-BP)
	SP-ZH-5P	SP-ZH-5P/BP
CODE	Female straight circular socket plug 5 pins	
TYPE	Male straight circular socket plug 5 pins	
MATERIAL	Plastic	
CABLE GLAND	PG9	
CABLE	for BC: CANBus Standard (301 DSP) for PS: LiYCY 5 x 0,25 shielded	PROFIBUS Standard
CONNECTION TYPE	screw terminal	
STANDARD	M12 - IEC 60947-5-2	
PROTECTION (DIN 40050)	IP 67	