

## Electronic drivers type E-ME-T-2\*H

Euro double card format, for single and double solenoid proportional valves with transducer

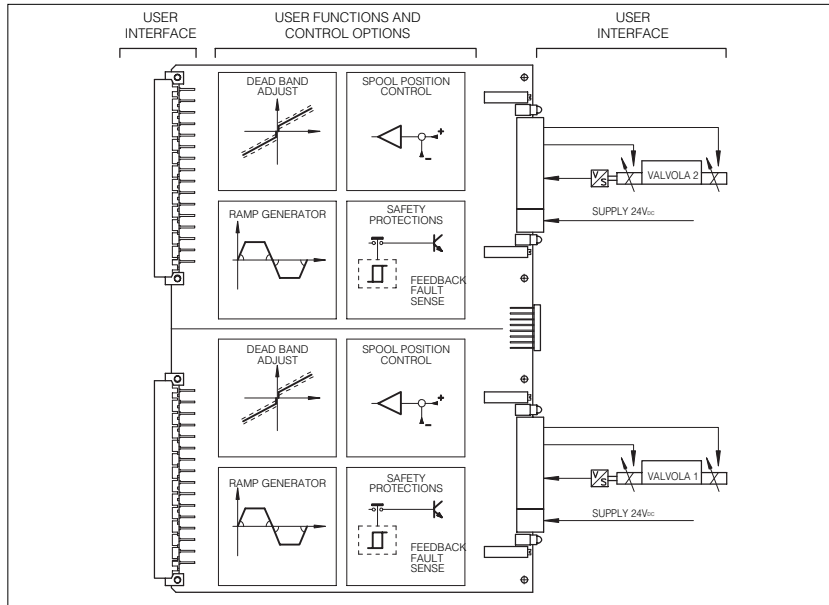

### 1 MODEL CODE

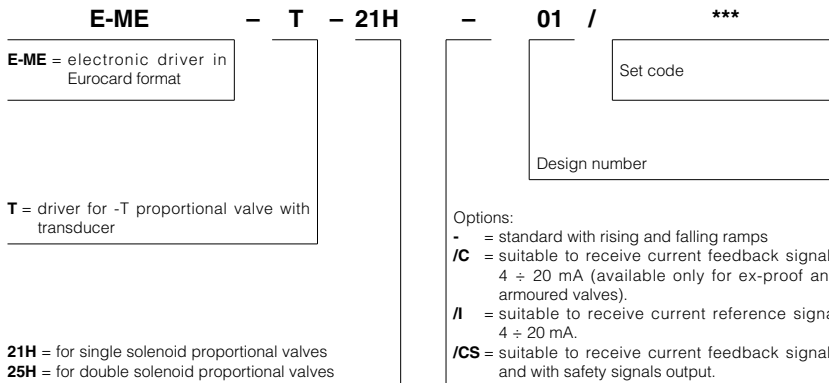

E-ME-T-2\*H electronic drivers supply single and double solenoid proportional valves type ZO(R)-T with the correct current signal to align valve regulation to the error signal.

The driver operates the spool's position control proportionally to the input voltage reference signals supplying a switching current to the solenoids. Bias adjustment is available for accurate valve regulations.

The Euro-double-card drivers allow additional safety signals to give a diagnostic state of the valves' spool position (option /CS) and cables' break emergency alarm (see [10] and [11] wiring block diagram).

It is designed to work on machines where couple of axes are controlled and where additional safety signals for checking the spool position are required. A typical application is the two-axes close-loop synchronization for bending presses.

This double driver is supplied already set, coupled with two suitable proportional valves, optimising their performances.

The electronic driver is in Eurocard format (2 x DIN 41494 - Plug-in-units). A backplane connector is used to wire low-power signals (setpoints, enable, etc.). Valve coil, transducer and power supply wires (24Vdc) are connected on the front side by means of a terminal board connector.

This version includes the following improved features:

- electronic filters on input and output lines;
- test point for reference and feedback on front panel.

### 2 BLOCK DIAGRAM

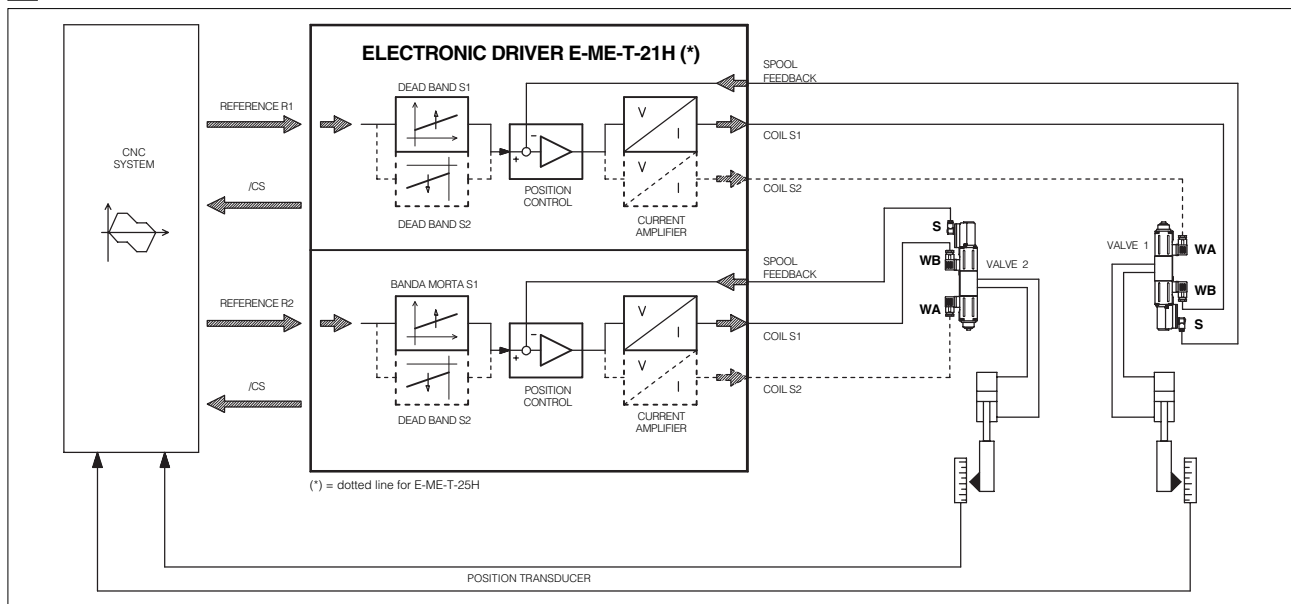

### 3 MAIN CHARACTERISTICS OF EACH SECTION OF E-ME-T-2\*H ELECTRONIC DRIVERS

Power supply (plug connector on front panel with two contacts) positive at contacts 2 (2a) negative at contacts 1 (2c, 4c)	Nominal : 24V <sub>DC</sub> Rectified and filtered : V <sub>RMS</sub> = 21 ÷ 28V <sub>DC</sub> (single-phase, full wave) Smooth battery voltage (continuous) : 21 ÷ 40V <sub>DC</sub>
Max power consumption	50 W per valve
Current supplied to solenoids	I <sub>max</sub> = 3,3 3,3 A type PWM square wave (with solenoid type ZO-T with resistance 3,2 Ω) I <sub>max</sub> = 2,5 A type PWM square wave (with explosion-proof solenoid with resistance 3,2 Ω)
Nominal reference signal	±10V ±10V differential amplifier at contact 20c (+) and 20a (-) (see 4.4)
Input signal impedance	R <sub>i</sub> > 50KΩ
Reference voltage for external electronics	-10V / 10mA from 32c contact +10V / 10mA from 32a contact
Diagnostic signals (option /CS)	Active high signal (22V / 20 mA) 0, S1, S2 (contacts 10a, 12a, 14a)
Enabling signal	V = 6 ÷ 40V <sub>DC</sub> on contact 16a with led indicator on front panel
Cable break fault alarm (22a)	Active low; no alarm: +24V (max 100mA)
Valve electrical wirings screw type 8 pin plug connector on front panel (plug included)	Coil S1 contacts 3,4 2 x 1 mm <sup>2</sup> up to 20 m - 2 x 1,5 mm <sup>2</sup> shielded up to 40m S2 contacts 5,6
	Transducer -15V contact 7 +15V contact 8 4 x 0,25 mm <sup>2</sup> up to 20m - 4 x 0,5 mm <sup>2</sup> shielded up to 40m rif. 0V contact 9 signal contact 10
Card format	Double Europe 233,4 x 160 x 40mm (width x length x height) (Plug-in unit DIN 41494)
Back card connector	Male connector DIN 41612/D
Connection elements available	Type E-K-32M/2 card holder/screw connections <b>to be ordered separately</b>
Operating temperature	0 ÷ +50°C (storage -20 ÷ +70°C)
Total weight	430 g (without front panel)
Features	Position control by PID action - Fast solenoid excitation and switching off. Outputs to solenoids protected against accidental short circuits. Feedback cable break alarm produces an inhibition of the driver, zeroing the current and creating a fail-safe position in the valve. Diagnostic state of the valve spool position.

### 4 GENERAL SPECIFICATIONS

#### 4.1 Power supply and wirings for each regulator

The power supply must be appropriately stabilized or rectified and filtered (use a 4700µF/63V capacitor when ripple > 10%). Never insert or remove the driver while the electronic system is powered on.

#### 4.2 Reference signal

The electronic driver is designed to receive external voltage reference signals according to [1], [2]. Connect the electronic driver according to [5], [2], [3].

#### 4.3 Set code

Basic calibration of the electronic driver is factory preset according to the proportional valve it has to be coupled with. The two drivers on the card E-ME-T-2\*H are supplied with the same basic calibration. These pre-calibrations are identified by a standard number in the model code as follows.

DH04SA = DLHZO-T-0\*, -T-0\*/B      DK14SC = DLKZO-T-1\*, -T-1\*/B  
DH07SA = DHZO-T-07\*              DK17SB = DKZOR-T-17  
DH07BA = DHZO-T-07\*/B          DK17BB = DKZOR-T-17/B

For **ex-proof valves**, insert an "A" in the fifth digit of the code adjustment; for example, the code adjustment for DLHZA-T is DH04AA: see table E120.

#### 4.4 Calibration/settings accessible to the user

##### - Scale

The relation between the driving current and the reference signal is fixed. For single solenoid valves with two external operating positions (-\*60, -\*40), the reference signal is ±10V (the same as double solenoid valve). Only for particular requirements a separate scale adjust for solenoid S1 and S2 (internal potentiometers P7, P16 for solenoid S1 and P8, P17 for solenoid S2) to obtain differential hydraulic operations in particular working conditions (see [7]).

##### - Bias (dead band compensation), see [8], [9].

Regulation of dead band adjust the hydraulic zero of the valve (adjustment of starting position) to the corresponding electrical zero. The electronic card is factory preset for the valve it is coupled with according to the set code (see section 4.3). For double solenoid driver E-ME-T-25H/\* a step function generator becomes active when the input reference voltage signal is greater than ±200mV enabling start current set by front panel bias potentiometers P1 and P2 for independent dead band regulation.

### 5 EXT. REFERENCE SIGNALS R1, R2

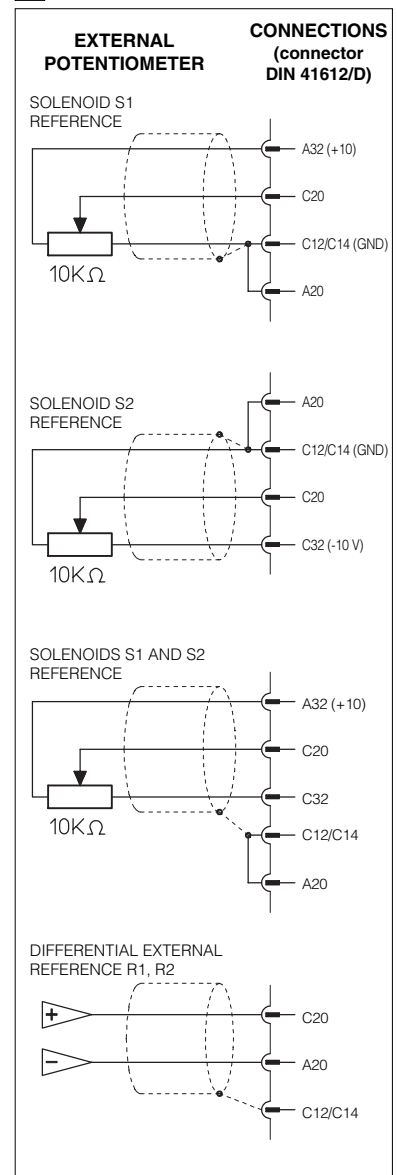

## 6 INSTALLATION AND START-UP

It is advisable to perform calibration procedures in the order given below.

### 6.1 Warning:

- Never insert or remove the driver while the electronic system is powered on.
- Voltages must always be measured with reference to GND (test point TP2).
- Refer to [7], [8] to identify components mentioned in calibration procedures.

### 6.2 Start-up

The operations described here follow must be applied to each driver on the card. Factory preset adjustment may not meet the desired requirements for the specific application and performances can be optimized by on-site re-adjustments of bias and scale potentiometers, in sequence. Connect each electronic driver according to the desired connection diagram (see [11], [12], [13]).

- **Enabling signal**, see [11], [12].

The electronic driver operate when the contact 16a is supplied with an enabling signal (usually 24V<sub>DC</sub>). It could be useful in emergency conditions to inhibit the driver by zeroing this signal (enable led off).

- **Bias adjustment** (dead band compensation), see [8], [9], [11].

For version E-ME-T-21H:

- supply a reference signal voltage 0 V<sub>DC</sub>;
- gradually operate the potentiometer P1 until stop of the controlled actuator is obtained.

For version E-ME-T-25H:

- supply a reference signal voltage +0,2 V<sub>DC</sub>;
- gradually turn clockwise the potentiometer P1 for solenoid S1 until a movement of the controlled actuator is obtained;
- gradually turn in the opposite sense the potentiometer P1 until stop of the controlled actuator is obtained;
- repeat the operation and supply a reference signal voltage -0,2 V<sub>DC</sub> by the potentiometer P2.

- **Scale adjustment**, see [8], [9], [11].

Factory preset reference signal is 0 ÷ +10V for E-ME-T-21H and ±10V for E-ME-T-25H (see paragraph 4.4). Only in particular cases when a non standard reference signal is available it is possible to adjust maximum valve opening with scale regulation proceeding as follow:

- supply a +10 VDC reference signal (for E-ME-T-25H repeat the operation for -10 V<sub>DC</sub> reference signal) and, if it is necessary, turn counterclockwise the internal scale potentiometers P7, P16 and P8, P17 (factory preset to 100%) to reduce valve opening (see [7]).

- **Diagnostics** (only for E-ME-T-25H with /CS option), see [10], [11], [12].

This function provides three output signals to check in real time the state of the valve spool position. The signal 0 (contact 10a) is active high (22V 20 mA) when the spool is in the center position; the other two signals (12a and 14a contacts) are active high when the spool moves into the position range controlled by excitation of coil S1 or S2 respectively.

## 7 E-ME-T-2\*H TOPOGRAPHICAL VIEW

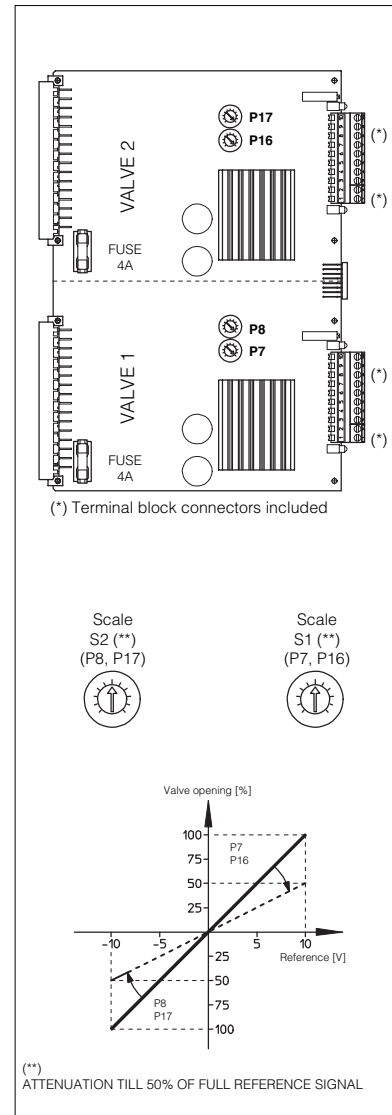

## 8 E-ME-T\*25H TOPOGRAPHICAL VIEW OF REGULATIONS

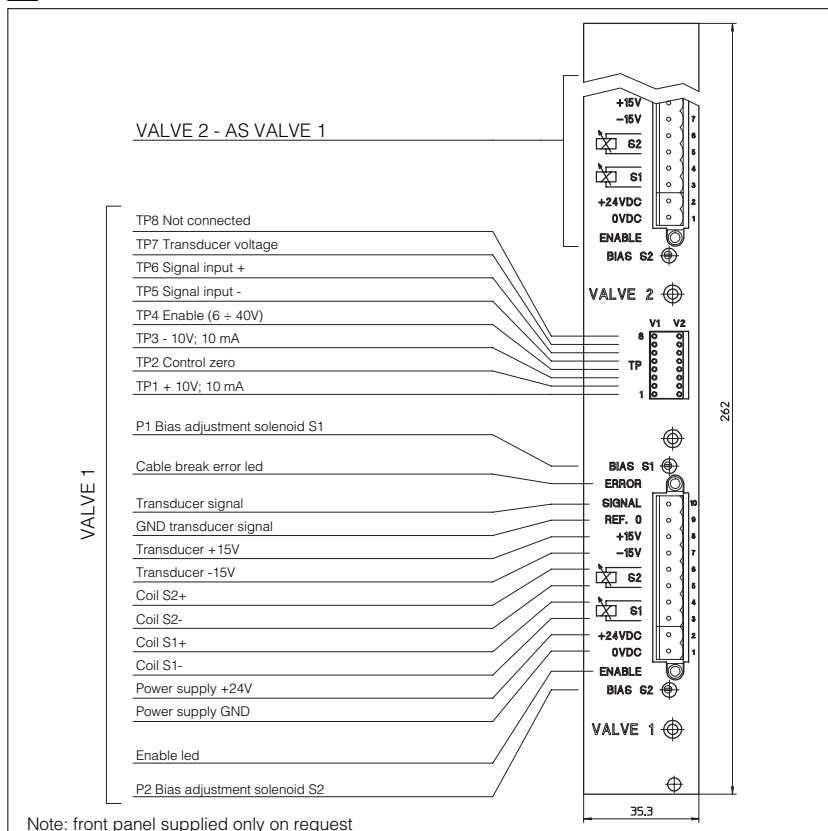

## 9 E-ME-T-2\*H DIAGRAM

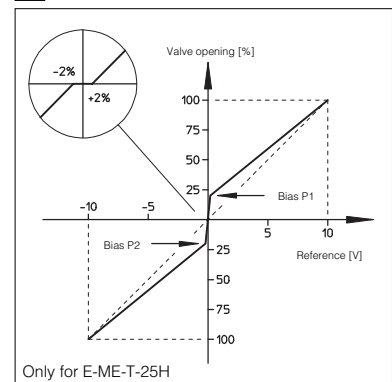

## 10 DIAGNOSTIC SIGNALS (option /CS)

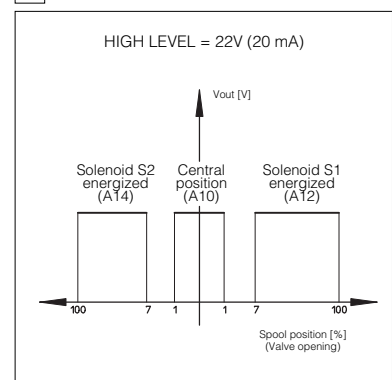

**11 WIRING BLOCK DIAGRAM (for each electronic driver)**

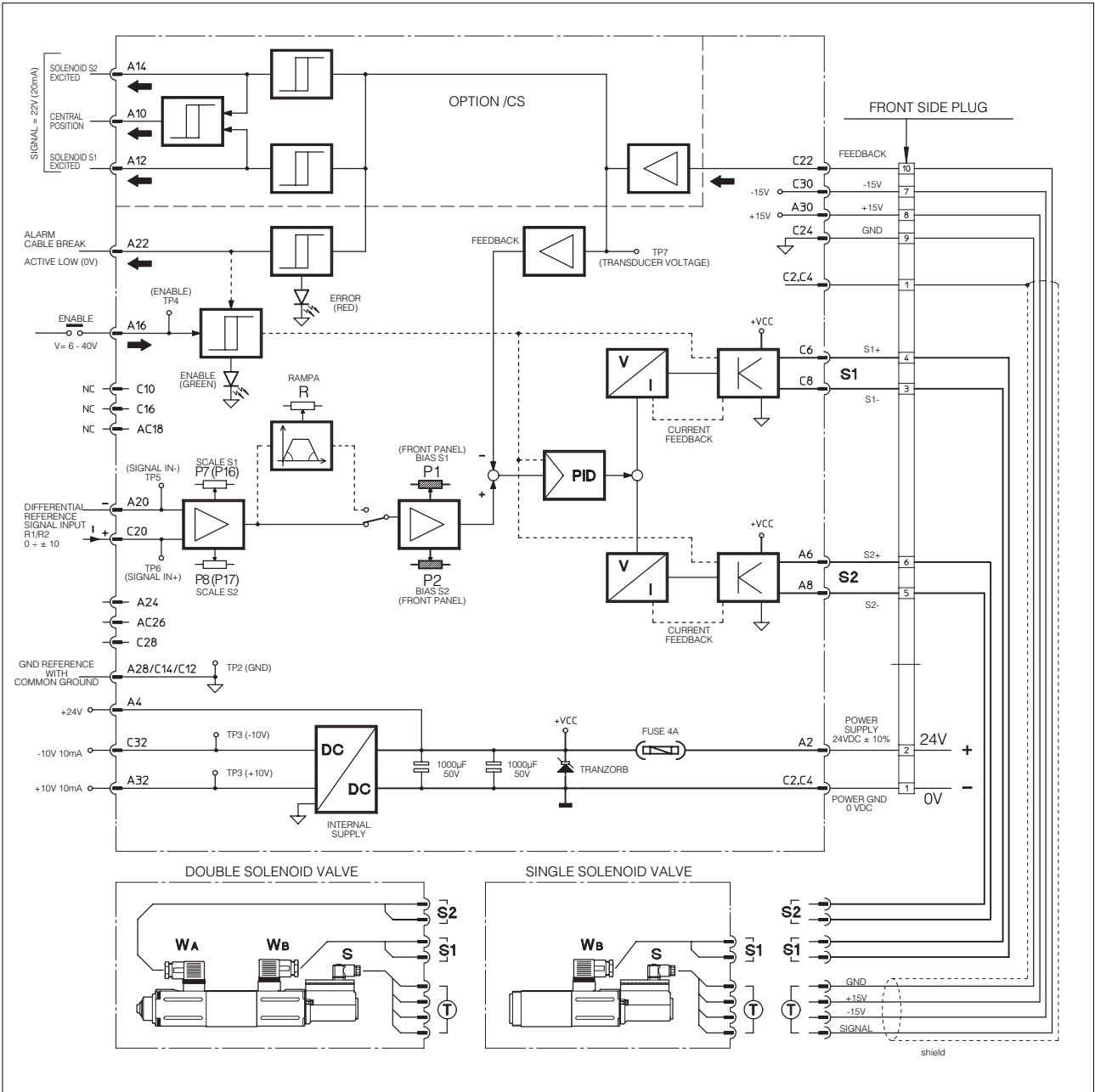

**12 REAR CONNECTIONS FOR EACH SECTION**

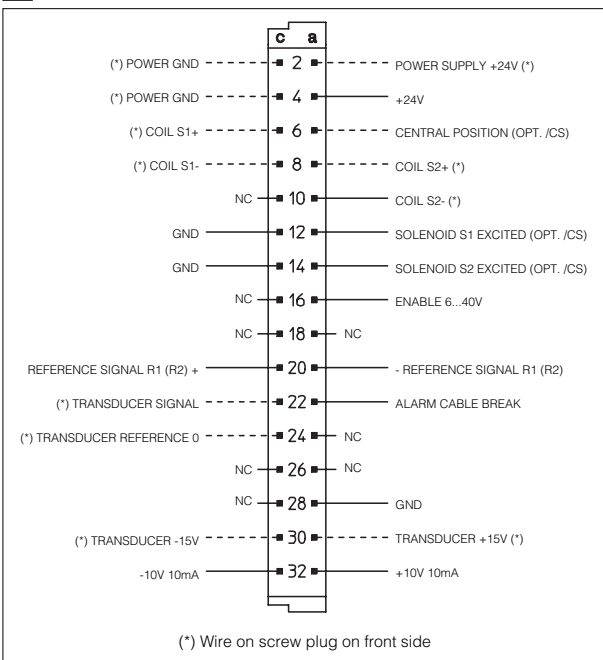

**13 FRONT PANEL CONNECTIONS FOR EACH SECTION**

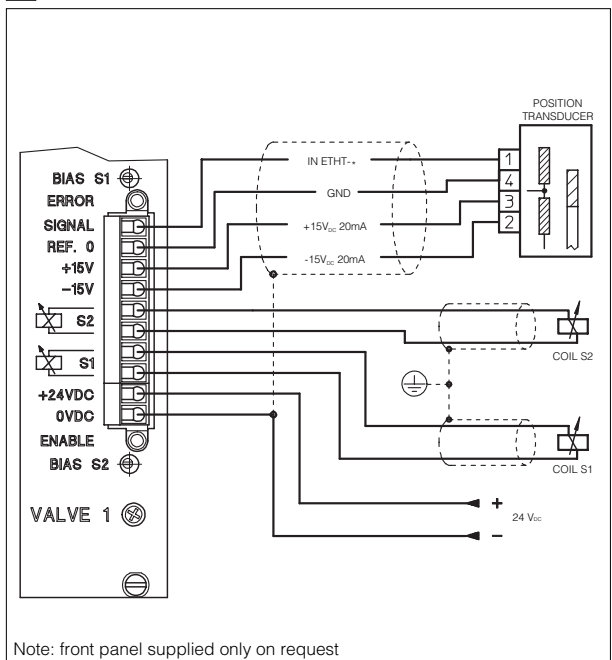

Note: front panel supplied only on request