

Digital integral drivers type E-RI-PES

for variable displacement axial piston pumps

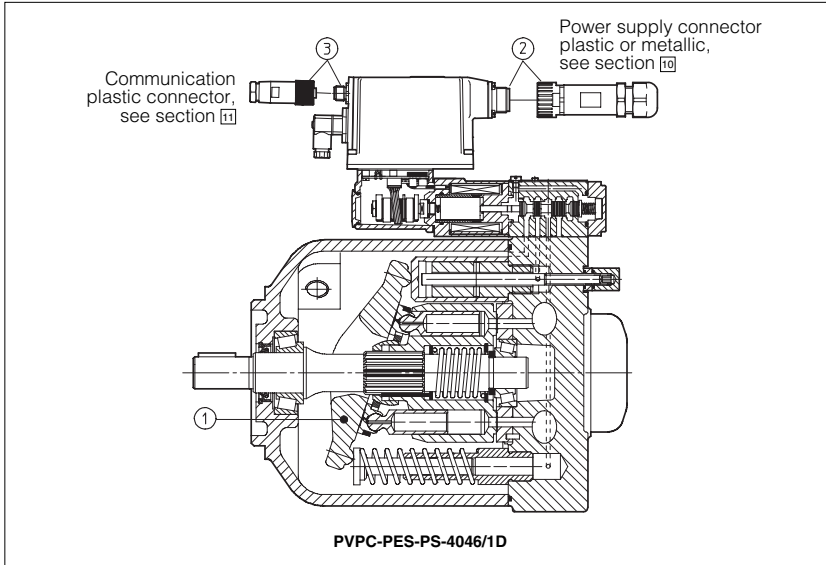

These digital drivers are integral to the Atos variable displacement axial piston pumps type PVPC. They control in closed loop the pump swashplate position ① and the system pressure according to the electronic reference signals realizing a P/Q regulation.

Features

- Integral digital electronics, factory preset
- Software setting of the main functional parameters as zero regulation, scale, ramps, by means of the relevant programming devices KIT-E-SW-*, see section 8.
- Possibility to optimize the application performances modifying via software internal parameters as the dynamic response (P.I.D.) and the regulation characteristics of the pump flow and pressure (linearization)
- Possibility of real time selection of different pressure PID parameters set during the axis motion, options /S and /Z.

Following communication interfaces ③ are available:

- -PS, RS232 serial communication interface. The pump reference signals are provided with analog commands via the 12 pins connector
 - -BC, CANbus interface
 - -BP, PROFIBUS-DP interface
- In the -BC and -BP executions the pump reference signal are provided via fielbus; during start up or maintenance, the pump can be operated with analog signals via the 12 pins connector.
- IP67 protection degree.
 - CE marking grants the conformity to the EMC Directive (Electromagnetic Compatibility).

1 MODEL CODE

E-RI - PE S - PS - 01H / * ** / *

Integral electronic driver

PE = PVPC pumps with P/Q control

S = digital electronic

Communication interfaces
 PS = RS232 serial
 BC = CAN-Bus
 BP = PROFIBUS-DP

01H = for single solenoid proportional valves

Options, see section 4
 - = standard version
 /X = with pressure transducer integral to the pump
 /C = with remote current transducer
 /S = with multiple PID parameters set - only for -PS
 /Z = as S but with double power supply, enable and fault - only for -BC and -BP

Set code
 Design number

Note: the set code identifies the correspondance between the digital integral driver and the relevant pump

2 ELECTRONIC AND WIRING BLOCK DIAGRAM FOR -PES

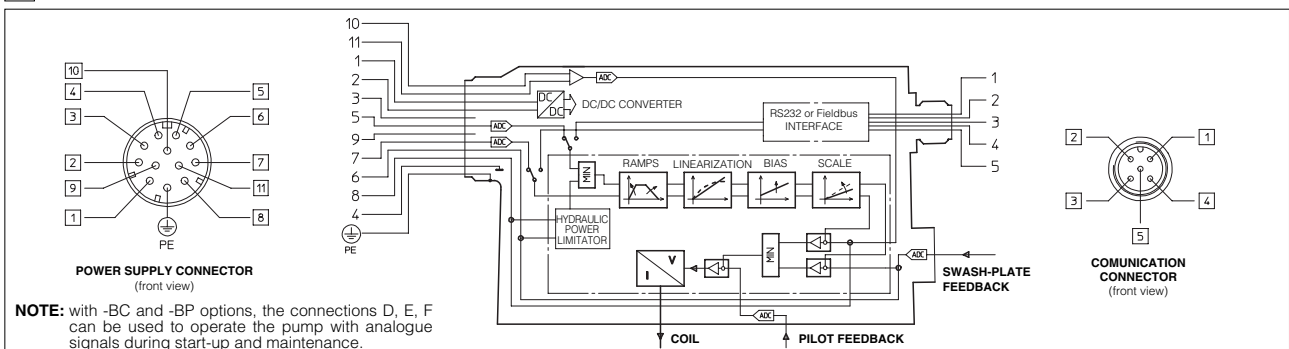

| POWER SUPPLY CONNECTOR | | | COMMUNICATION CONNECTOR | | | |
|------------------------|-------------------------------------|--|---------------------------------|----------------------------|-------------------------------------|--|
| PIN | DESCRIPTION SIGNAL | SIGNAL | Communication option | -PS (RS232) Male connector | -BC (CAN Bus) Male connector | -BP (PROFIBUS-DP) Female connector (reverse key) |
| 1 | power supply 24 V _{dc} | Stabilized: +24 V _{dc} | PIN number - Signal description | 1 | CAN_SHLD | +5V Termination voltage |
| 2 | power supply zero | Filtered-rectified: V _{rms} 21-33 (ripple max 2 V _{pp}) | | 2 | Shield | LINE -A Bus line (high signal) |
| 3 | Fault | Alarm = 0 V _{dc} Correct functioning = +24 V _{dc} | | 3 | RS_GND Signal zero data line | DGND Signal zero data line / termination voltage |
| 4 | Signal zero | Reference 0 V _{dc} | | 4 | RS_RX valves receiving data line | CAN_H Bus line (high signal) |
| 5 | Flow input signal | 0 ÷ 10 V _{dc} (referred to pin 4) | | 5 | RS_TX valves transmitting data line | CAN_L Bus line (low signal) |
| 6 | Flow monitor | 0 ÷ 10 V _{dc} (referred to pin 4) | | | | SHIELD |
| 7 | Pressure input signal | 0 ÷ 10 V _{dc} (referred to pin 4) | | | | |
| 8 | Pressure monitor | 0 ÷ 10 V _{dc} (referred to pin 4) | | | | |
| 9 | Power limitation enable | > 9 to +24 V _{dc} | | | | |
| 10 | Pressure feedback + V _{dc} | 0 ÷ 10 V _{dc} pressure feedback (not connected with option /X) | | | | |
| 11 | Pressure feedback 0 | 4 ÷ 20 mA with option /C | | | | |
| PE | Earth | Connect only with supply not conforming to VDE 0551 (CEI 16/6) | | | | |

3 ELECTRONIC AND WIRING BLOCK DIAGRAM FOR -PES/S and -PES/Z

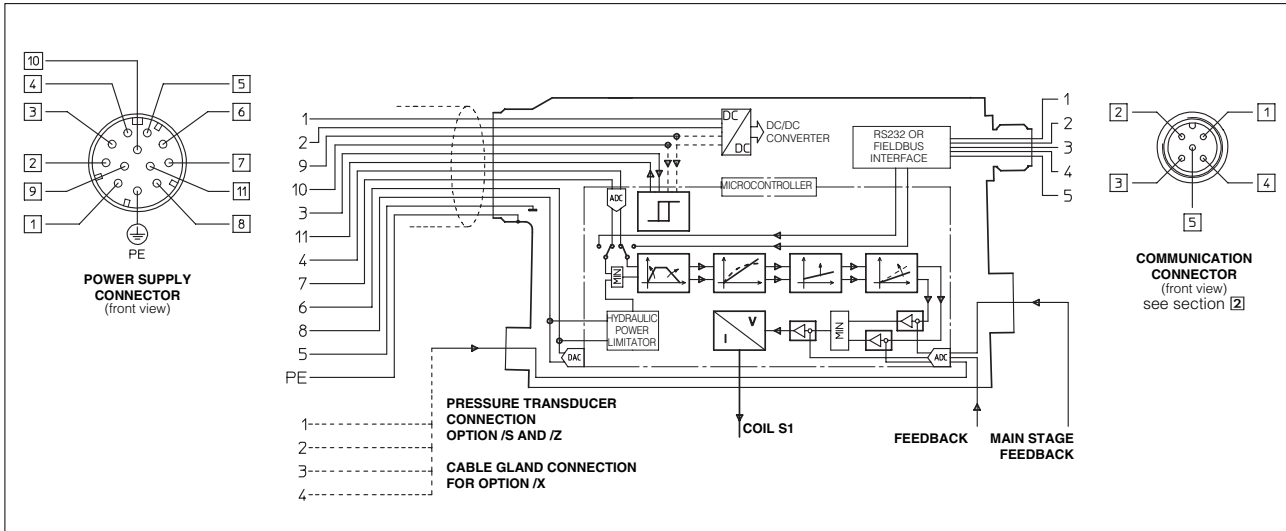

| POWER SUPPLY CONNECTOR (OPTION /S) only for /PS | | | POWER SUPPLY CONNECTOR (OPTION /Z) only for /BC and /BP | | |
|---|-----------------------------------|--|---|-----------------------------------|--|
| PIN | SIGNAL DESCRIPTION | TECHNICAL SPECIFICATION | PIN | SIGNAL DESCRIPTION | TECHNICAL SPECIFICATION |
| 1 | Power supply 24 Vdc (power stage) | Stabilized: +24 Vdc | 1 | Power supply 24 Vdc (power stage) | Stabilized: +24 Vdc |
| 2 | Power supply 0 Vdc (power stage) | Filtered and rectified: Vrms 21-33 (ripple max 2 Vpp) | 2 | Power supply 0 Vdc (power stage) | Filtered and rectified: Vrms 21-33 (ripple max 2 Vpp) |
| 3 | Enable | Enabling input normal working 24 Vdc | 3 | Enable | Enabling input normal working 24 Vdc |
| 4 | Flow input signal | $\pm 10 \text{ Vdc} - 0 \div 10 \text{ Vdc}$ | 4 | Flow input signal | $\pm 10 \text{ Vdc} - 0 \div 10 \text{ Vdc}$ |
| 5 | Signal zero | Reference 0 Vdc | 5 | Signal zero | Reference 0 Vdc |
| 6 | Flow monitor | $\pm 10 \text{ Vdc}$ referred to pin 5 | 6 | Flow monitor | $\pm 10 \text{ Vdc}$ referred to pin 5 |
| 7 | Pressure input signal | $\pm 10 \text{ Vdc} - 0 \div 10 \text{ Vdc}$ | 7 | Pressure input signal | $\pm 10 \text{ Vdc} - 0 \div 10 \text{ Vdc}$ |
| 8 | Pressure monitor | $\pm 10 \text{ Vdc}$ referred to pin 5 | 8 | Pressure monitor | $\pm 10 \text{ Vdc}$ referred to pin 5 |
| 9 | PID selection | Zero or +24 Vdc | 9 | Power supply 24 Vdc (logic stage) | Stabilized: +24 Vdc |
| 10 | (see section 4.3) | | 10 | Power supply 0 Vdc (logic stage) | Filtered and rectified: Vrms 21-33 (ripple max 2 Vpp) |
| 11 | Fault | Alarm = 0 Vdc Correct functioning = +24 Vdc | 11 | Fault | Alarm = 0 Vdc Correct functioning = +24 Vdc |
| PE | Earth | Connect only when the power supply is not conform to VDE 0551 (CEI 14/6) | PE | Earth | Connect only when the power supply is not conform to VDE 0551 (CEI 14/6) |

4 OPTIONS

4.1 Option /X

Option providing the presence of the pressure transducer, with output signal $4 \div 20 \text{ mA}$, integral to the pump and factory wired to the PES electronics through a cable gland.

4.2 Option /C

The pump electronics is set to receive $4 \div 20 \text{ mA}$ feedback signal from the remote pressure transducer, instead of the standard $0 \div 10 \text{ V}$.

4.3 Option /S (only for /PS)

Option providing up to 4 set pressure of PID parameters real time selectable during the axis motion via on-off signals to the 12 poles connector to optimize the control performances in the different phases of the machine cycle. The selection of the pressure PID parameters set must be performed according the sequence, set 1 \rightarrow set 2 \rightarrow set 3 \rightarrow set 4 and viceversa.

| PID SET SELECTION | | | | |
|-------------------|-------|--------|--------|--------|
| PIN | SET 1 | SET 2 | SET 3 | SET 4 |
| 9 | 0 | 0 | 24 Vdc | 24 Vdc |
| 10 | 0 | 24 Vdc | 24 Vdc | 0 |

4.4 Option /Z (only for /BC and /BP)

Option providing the same characteristics of option /S plus additional double power supply, enable and fault. The multiple set of pressure PID parameters can be real time selected during the axis motion through the -BC or -BP interfaces to optimize the control performances in the different phases of the machine cycle. The double power supply is specifically introduced for -BC and -BP fieldbus interfaces and it provides two separated power supplies for the digital electronic circuits and for the pilot valve power supply stage. It allows to interrupt the pump functioning by cutting the solenoid power supply of the pilot valve (e.g. for emergency, as provided by the European Norms EN954-1 for components with safety class 2), but keeping energized the digital electronic circuits, thus avoiding fault conditions of the machine fieldbus controller.

4.5 Pressure transducer connector (options /S and /Z)

The pressure transducer and the 4 poles connector type **SP-ZH-4P-M8/5** have to be ordered separately. See section 11 for the 4 poles connector and tab. G460 for the pressure transducer.

| PIN | options /S and /Z | option /C (Ri = 316 Ω) |
|-----|---|--------------------------------|
| 1 | Pressure - real value | Pressure signal |
| 2 | Common zero for power supply and signal | Not connected |
| 3 | Transducer power supply 24 Vdc | Power supply |
| 4 | Not connected | Not connected |

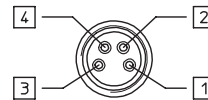

PRESSURE TRANSDUCER CONNECTOR options /S and /Z
(front view)

4.6 Current reference signal (option /I)

The digital drivers with option -PS can be supplied, **on request**, with $4 \div 20 \text{ mA}$ current reference signals and feedback signals, instead of the standard $0 \div 10 \text{ Vdc}$.

5 MAIN CHARACTERISTICS OF DIGITAL INTEGRAL ELECTRONIC DRIVERS

| | | | |
|---------------------------------------|---|---|---|
| Driver section | | | |
| Format | Sealed box on the valve - Protection: IP67 DIN 40050 - Insulation: VDE0110 | | |
| Electromagnetic compatibility (EMC) | Emission: EN 50081-2 - Immunity: EN 50082-2 | | |
| Max power consumption | 50 W | | |
| Current supplied to solenoid | I _{max} = 3.3 A square wave PWM type | | |
| Analog input signal impedance | Voltage signal R _i > 50KΩ | | |
| Operating temperature | -20°C ÷ +60°C (storage -20°C ÷ +70°C) | | |
| Alarm messages | Electronic overcurrent and overtemperature | | |
| Features | Pressure control by P.I.D. - Rapid solenoid excitation and switching off – Output to solenoids protected against accidental short circuits – Feedback cable break produces an inhibition of the driver, zeroing the current to the solenoid | | |
| Communication options | RS232 interface (option -PS) | CAN-Bus interface (option -BC) | Profibus-DP interface (option -BP) |
| Serial input format | RS232C serial connection | Industrial field-bus with optical insulation type CAN-Bus ISO 11898 | Industrial field-bus with optical type PROFIBUS - DP European fieldbus standard EN 50170 part 2 |
| Communication Protocol | Atos protocol with ASCII coding | CANopen EN50325-4 Device Profile DS408 | PROFIBUS - DP EN50170-2 IEC61158 |
| Programming interface - see section 8 | Software interface (see tab. G500) | Software interface (see tab. G500) or master CANbus device | Software interface (see tab. G500) or master PROFIBUS device |

Note: A minimum time of 300 to 500 ms have be considered between the driver energizing with the 24 Vdc power supply and when the valve is ready to operate. During this time the current to the valve coils is switched to zero.

6 SOFTWARE SETTINGS

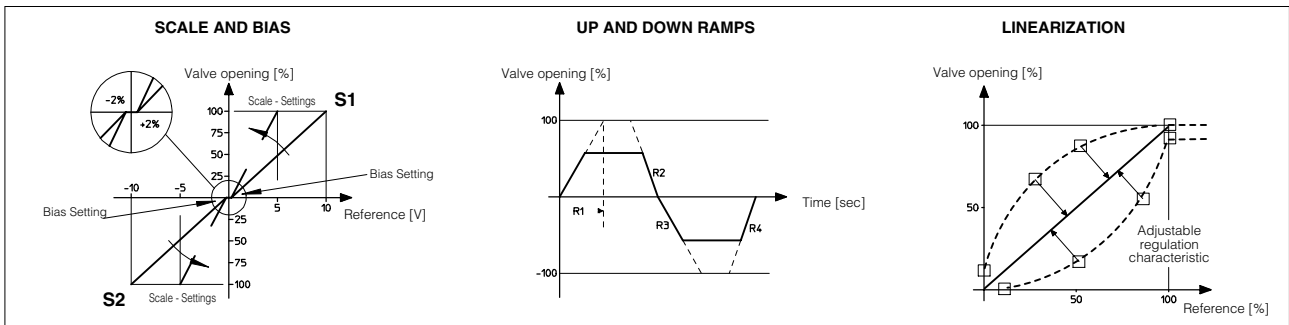

In addition to the above settings, other software regulations are available:

- Customized configuration of the reference signal, instead of standard $\pm 10V$
- Internal self generation of the reference signal. This function is particularly useful during start-up or maintenance
- P.I.D. parameters setting to optimize at the pump dynamic control
- Alarm setting of the high/low limits of the electronics temperature
- Alarm setting of the control deviation (max difference between the reference signal and the regulation monitors after a selected time).
- Hydraulic power limitation

7 DIMENSIONS OF DIGITAL INTEGRAL ELECTRONIC DRIVERS AND CONNECTORS [mm]

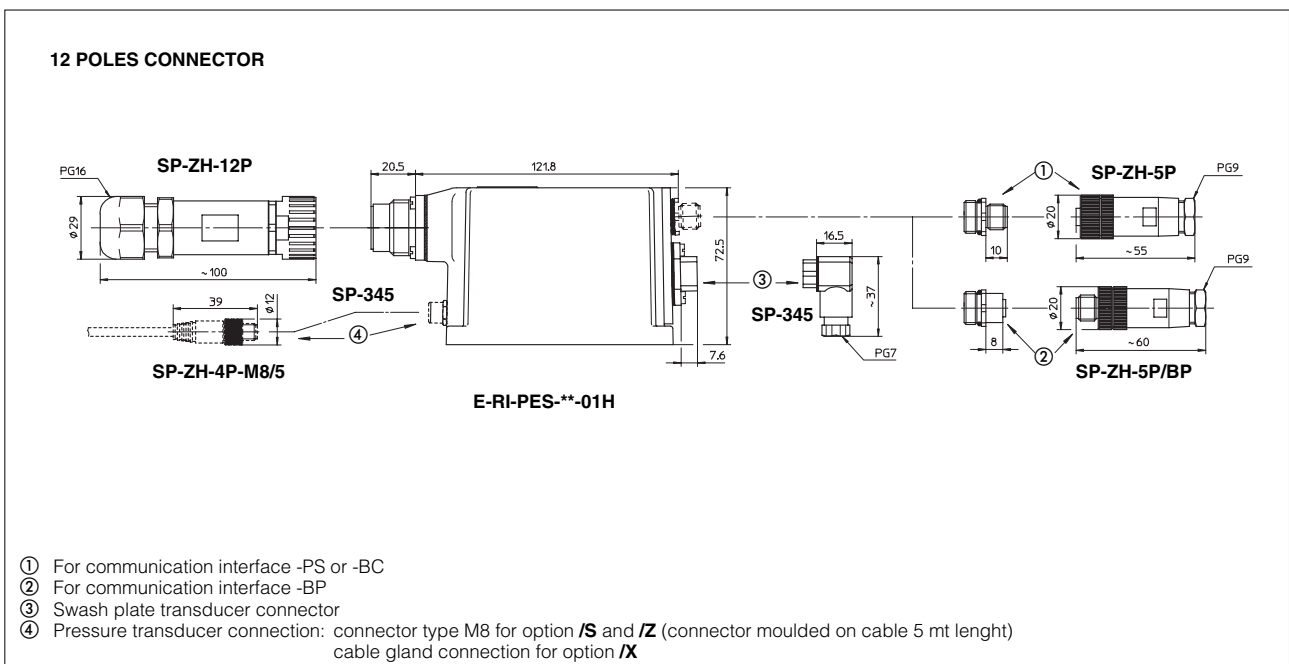

8 PROGRAMMING DEVICES

The functional parameters of the digital pump, as the zero, scale, ramp and linearization of the regulation characteristic, can be easily set and optimized with graphic interface by using the following software programming devices suitable for standard PC:

KIT-E-SW-PS for electronics with RS232 interface (option **-PS**)

KIT-E-SW-BC for electronics with CANbus interface (option **-BC**)

KIT-E-SW-BP for electronics with PROFIBUS-DP interface (option **-BP**)

see tab. G500 for complete information about the programming device kits and for the PC minimum requirements.

Only for the **-BC** and **-BP** communication options, the functional parameters can be alternatively set via fieldbus through the machine control unit, using the standard communication protocols implemented by Atos.

The protocol operating instructions to be implemented in the standard protocols (DS301V4.02, DSP408 for CANbus and DPVO for PROFIBUS-DP) are described in the user manuals MAN-S-BC (for **-BC** option) and MAN-S-BP (for **-BP** option) supplied with the relevant programming device kits.

The above programming devices have to be ordered separately.

9 FIELDBUS FEATURES

9.1 CANbus - CANopen features implemented in Atos protocol

| | |
|--------------------|--|
| Protocol | CANopen version DS301 V4.02 |
| Network error ctrl | Node Guarding |
| Boot up process | Minimum boot-up |
| Node ID, Baudrate | setting via LSS (Layer Setting Services) and via SDO |
| Number of RPDO | Two Receive PDOs (mappable parameters) |
| Number of TPDO | Two Transmit PDOs (mappable parameters) |
| Number of SDO | One Receive SDO and one Transmit SDO |
| Device Profile | DSP408 Device Profile Fluid Power Technology |
| Configuration | Physical Layer: ISO11898 (transmission rates from 10 Kbit/s to 1 Mbit/s) Data Link Layer: Based on CAN standard frame with 11-bit identifier (CAN 2.0A) |
| Info (file) | EDS file (Electronic Device Data Sheet) enclosed in a CD-ROM (Kit-E-SW-BC) with the proper manual |

9.2 Profibus DP features implemented in Atos protocol

| | |
|----------------------------------|---|
| Protocol | Profibus version DPV0 |
| Error control | SAP 60 |
| Boot up proces | SAP 61, SAP 62 |
| Node ID | SAP 55 or dip-switches hardware |
| Cyclic and Acyclic communication | PPO Telegrams: Type 5 for real-time and parameter communication (string management is realized with an Atos algorithm, see Kit-MAN-S-BP) - processed data area (PZD) of PPO telegram is mappable. |
| Device profile | PROFIBUS Profile: Fluid Power Technology |
| Configuration | Physical Layer: (lev.1 - EN50170 part. 2) rates from 9,6 Kbit/s to 12 Mbit/s, up to 126 stations (with repeaters) Data Link Layer: (lev.2 - EN50170 part 3/4) |
| Info (file) | GSD file (Electronic Device Data Sheet) enclosed in a CD-ROM (Kit-E-SW-BP) with the proper manual |

10 CHARACTERISTICS OF POWER SUPPLY CONNECTORS (to be ordered separately)

| CONNECTOR TYPE | POWER SUPPLY CONNECTOR |
|------------------------|--|
| CODE | SP-ZH-12P |
| TYPE | Female straight circular socket plug 12 pins |
| MATERIAL | Plastic reinforced with fiber glass |
| CABLE GLAND | PG16 |
| CABLE | LiCY 10 x 0,14 mm ² (signal) LIYY 3 x 1 mm ² (alimentation) |
| CONNECTION TYPE | to crimp |
| STANDARD | DIN 43651 |
| PROTECTION (DIN 40050) | IP 65 |

11 CHARACTERISTICS OF COMMUNICATION AND OF PRESSURE TRANSDUCER CONNECTORS (to be ordered separately)

| CONNECTOR TYPE | RS232 CONNECTOR (-PS) or CAN-Bus (-BC) | PROFIBUS CONNECTOR (-BP) | PRESSURE TRANSDUCER CONNECTOR OPTIONS /S AND /Z |
|------------------------|--|---|--|
| CODE | SP-ZH-5P | SP-ZH-5P/BP | SP-ZH-4P-M8 (1) |
| TYPE | Female straight circular socket plug 4 pins | Male straight circular socket plug 5 pins | Male straight circular socket plug 4 pins |
| MATERIAL | Plastic | Plastic | Plastic |
| CABLE GLAND | PG9 | PG9 | (1) |
| CABLE | for -BC: CANBus Standard (301 DSP) for -PS: LiYCY 5 x 0,25 shielded | PROFIBUS Standard | 4x0,25 mm ² |
| CONNECTION TYPE | screw terminal | screw terminal | to solder |
| STANDARD | M12 - IEC 60947-5-2 | M12 - IEC 60947-5-2 | M8 - IEC 60947-5-2 |
| PROTECTION (DIN 40050) | IP 67 | IP 67 | IP 67 |

(1) Connector moulded on cable with 5 mt lenght)