



ALUMINIUM PUMPS AND MOTORS **Z2 SERIES**

POMPE E MOTORI IN ALLUMINIO SERIE Z2

MADE IN ITALY



Ronzio Oleodinamica fu fondata nel 1950 da Dante Ronzio esperto in meccanica di precisione.

La prima attività dell'azienda fu la lavorazione di pompe per motori diesel, seguita, qualche anno più tardi, dalla costruzione di pompe oleodinamiche ad ingranaggi, che presto divenne la produzione prevalente.

La passione del fondatore per la meccanica fine ha lasciato nella Ronzio Oleodinamica un'impronta significativa; il motto dell'azienda è sempre stato quello di operare all'insegna della qualità e precisione, sia nell'impiego delle materie prime sia nel controllo del processo produttivo.

Ronzio Oleodinamica produce ora pompe, motori e divisori di flusso che trovano impiego in molti settori industriali sia nel veicolo che negli impianti fissi, nelle macchine agricole, forestali e nel movimento terra.

La struttura snella della nostra azienda e la nostra esperienza sono la risposta ai clienti che cercano in noi non solo un fornitore ma un partner nello sviluppo dei loro progetti.

Il nostro sistema qualità è certificato da DNV dal 1998.

Ronzio Oleodinamica was established in 1950 by Mr. Dante Ronzio, fond of precision mechanics.

The company started its activity machining pumps for diesel motors. The passion of the founder for fine mechanics left an important mark in the company. The production of hydraulic gear pumps started some years later and became soon the main activity of the company.

Since the beginning Ronzio Oleodinamica has been focusing on quality and precision. Our company uses top quality components and the most advanced computerized machines, both in the production and in the testing process.

Ronzio Oleodinamica manufactures gear pumps, motors and flow dividers in aluminium and in cast iron for a wide range of industries including: constructions, forestry, agriculture, industrial vehicles, earth moving, industrial.

Today, our products are worldwide appreciated.

Our experience and our lean structure are suitable for customers who need a direct involvement of the supplier in their projects.

Our quality system has been certified by DNV since 1998.

Caratteristiche principali

- ◆ Coperchi in ghisa per elevate prestazioni.
- ◆ Possibilità di funzionare ad alte pressioni: fino a 300 bar di pressione massima in funzionamento continuo.
- ◆ Compensazione assiale per il recupero dei giochi
- ◆ Alto rendimento volumetrico: 95-97% medio.
- ◆ Ampia disponibilità di cilindrata: 4-6-8-11-14-17-20-25-31 cm³/giro.
- ◆ Corpo in alluminio estruso.
- ◆ Progetto accurato del profilo del dente per avere una bassa rumorosità.
- ◆ Vasta gamma di flange, alberi e connessioni compatibili con i principali standard del mercato.
- ◆ Disponibilità di guarnizioni per alte temperature.
- ◆ Pompe e motori unidirezionali.
- ◆ Pompe e motori bidirezionali.
- ◆ Possibilità di montaggio di pompe multiple sia nelle serie in alluminio che con altre serie in ghisa prodotte da Ronzio Oleodinamica.
- ◆ Facilità di trasformazione: da pompa singola in pompa multipla e di cambio rotazione.

Main Features

- ◆ *Cast iron covers for high performances.*
- ◆ *High pressure option: up to 300 bar max. continuous pressure (4350 psi).*
- ◆ *Axial compensation achieved using pressure balanced bushing blocks.*
- ◆ *High volumetric efficiency: average 95-97%.*
- ◆ *Wide range of capacities: 4-6-8-11-14-17-20-25-31-cm³/rev.*
- ◆ *Extruded aluminium body.*
- ◆ *Gear tooth profile accurately projected providing low noise operation.*
- ◆ *A wide variety of shafts, flanges and ports are available to meet specific application requirements.*
- ◆ *High-temperature seals available.*
- ◆ *Single rotational pumps and motors.*
- ◆ *Bi-rotational pumps and motors.*
- ◆ *Multiple pumps availability: tandem pumps are possible both in aluminium series and with other cast iron series by Ronzio Oleodinamica.*
- ◆ *Easy-to-make tandem pumps and easy change of rotation.*

CONDIZIONI PER L'UTILIZZO DELLE POMPE E MOTORI "Z2"

USE CONDITIONS FOR PUMPS AND MOTORS "Z2"

Nell'utilizzo della pompa evitare carichi radiali e assiali sull'albero.

Il giunto di trascinamento deve compensare eventuali errori di allineamento, deve essere di tipo elastico oppure di tipo Oldham.

Per un corretto funzionamento e una lunga durata della pompa, osservare i valori riportati nella tabella seguente.

Avoid radial and axial loads on the pump shaft during the use.

The pump must be in line with the P.T.O. to compensate misalignment errors, use flexible or "Oldham" coupling.

We recommend to read the specifications in this catalogue very carefully. This will help you in getting the best, in terms of working conditions and life, from Ronzio gear pumps.

CONDIZIONI DI L'UTILIZZO USE CONDITIONS

Fluidi idraulici Hydraulic fluids	Oli idraulici a base minerale (DIN 51524). Per utilizzo di fluidi non infiammabili come acqua e glicole, emulsione di olio in acqua o esteri fosforici, contattare il nostro ufficio tecnico o commerciale. Mineral oil (DIN 51524). For use with fire resistant fluids like water glycol, water-oil emulsion and phosphate-esters, contact our technical or commercial office.			
Pressione in aspirazione Inlet pressure	0.7 - 3 bar (Assoluti / Absolute) 10 - 44 psi (Assoluti / Absolute)			
Velocità olio nella linea di aspirazione Oil speed on suction line	0.5 ÷ 1.5 m/s			
Velocità olio nella linea di mandata Oil speed on pressure line	6 ÷ 10 m/s			
Temperatura olio Oil temperature	-10°C ÷ 80°C			
Viscosità olio Oil viscosity	20 ÷ 120 mm ² /s (Cst)			
Massima viscosità olio all'avvio Max starting viscosity	700 mm ² /s (Cst)			
Filtraggio olio Oil filtration	Pressione (bar) Pressure (bar)	< 140	140 > 210	>210
	Classe di contaminazione NAS 1638 Contamination class NAS 1638	10	9	8
	Classe di contaminazione ISO 4406:1999 Contamination class ISO 4406:1999	21/19/16	20/18/15	19/17/14
	Rapporto β ₁₀ ≥ 75 - ISO16889 Ratio β ₁₀ ≥ 75 - ISO16889	//	10 μm	10 μm
	Rapporto β ₂₅ ≥ 200 - ISO16889 Ratio β ₂₅ ≥ 200 - ISO16889	25 μm	//	//

FORMULE PER DIMENSIONAMENTO DETERMINATION OF NOMINAL SIZE

PER POMPE
FOR PUMPS

$$Q = \frac{V * \eta_v * n}{1000}$$

$$M = \frac{p * V}{62.8 * \eta_m}$$

$$P = \frac{p * Q}{600 * \eta_t}$$

PER MOTORI
FOR MOTORS

$$Q = \frac{V * n}{1000 * \eta_v}$$

$$M = \frac{p * V * \eta_m}{62.8}$$

$$P = \frac{p * Q * \eta_t}{600}$$

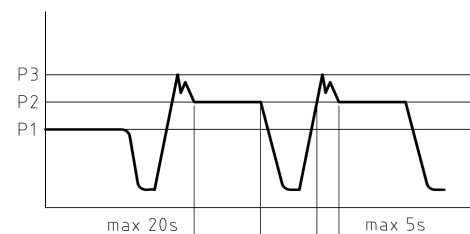

V [cm³]
Q [l/min]
p [bar]
M [Nm]
n [min⁻¹]
P [Kw]

η_v = EFF vol. ≥ 95
η_m = EFF mecc. ~ 0.85
η_t = η_v * η_m. ~ 0.8

CARATTERISTICHE PRINCIPALI
MAIN CHARACTERISTICS

Tipo - Type		04	06	08	11	14	17	20	25	31
Cilindrata Capacity	Cm ³ / giro Cm ³ / rev	4.4	6.28	8.16	11.3	14.45	16.95	20.1	25.75	31.4
P1 Pressione max continua Max working pressure	Bar	300	300	300	300	300	270	230	180	160
P2 Pressione intermittente intermittent pressure	Bar	340	310	310	310	300	270	240	200	170
P3 Pressione max di picco Max peak pressure	Bar	360	360	360	360	360	330	290	230	200
Velocità max per pressione P1 Max speed for P1 pressure	Giri / min Rpm	4500	4500	3700	3300	2700	2500	2500	2500	2200
Velocità max a vuoto Max speed without load	Giri / min Rpm	5500	5500	4700	4000	3300	3000	3000	3000	2700
Velocità min. per pressione P1 Min speed for P1 pressure	Giri / min Rpm	1000	700	550	450	400	350	300	250	200

VERIFICARE, ATTRAVERSO LE FORMULE A PAGINA 4, LA COMPATIBILITÀ TRA LE PRESTAZIONI DI PRESSIONE E PORTATA RICHIESTE, E LA CAPACITÀ DELL'ALBERO DI TRASCINAMENTO DI SOPPORTARE LA COPPIA RICHIESTA.

VERIFY THE COMPATIBILITY AMONG PERFORMANCE OF PRESSURE, FLOW REQUIRED AND TORQUE OF THE SHAFT THROUGH THE FORMULAS ON PAGE 4.

Per pompe o motori bidirezionali, diminuire la pressione del 15%.
 With bidirectional pumps or motors, pressure is reduced by 15%.

COMPONENTI
PARTS

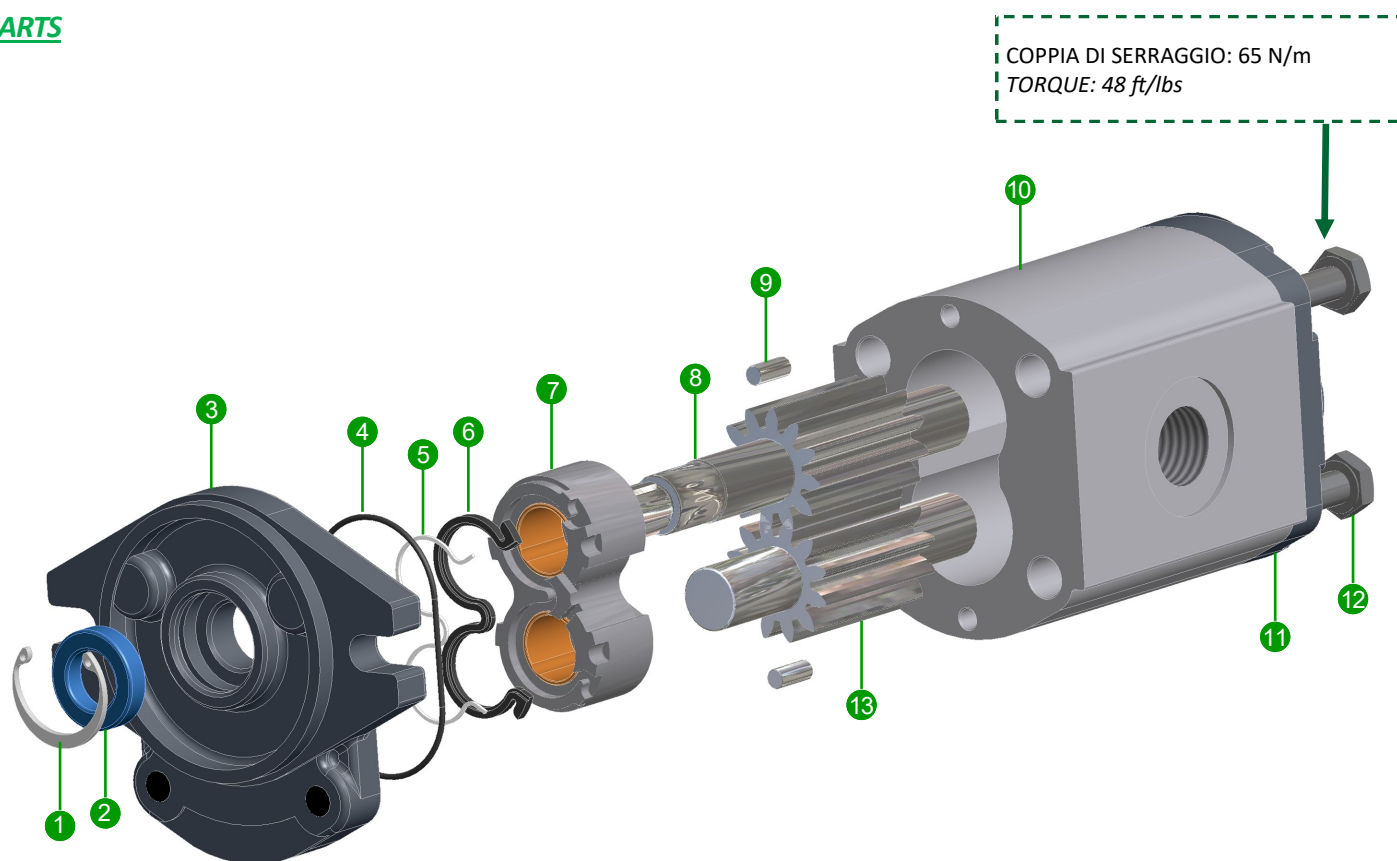

Rif.	Descrizione	Description	Qt.
1	Anello elastico	Snap ring	1
2	Anello di tenuta	Rotary shaft seal	1
3	Flangia	Front flange	1
4	Guarnizione sotto-coperchio	Under cover seal	2
5	Antiestrusore	BK seals	2
6	Guarnizione di compensazione	Compensation seal	2
7	Rasamento	Bushing block	2
8	Ingranaggio conduttore	Drive gear	1
9	Spina cilindrica	Pin	4
10	Corpo	Housing	1
11	Coperchio	Rear cover	1
12	Vite	Bolt	4
13	Ingranaggio condotto	Idle gear	1

SENSO DI ROTAZIONE

ROTATION

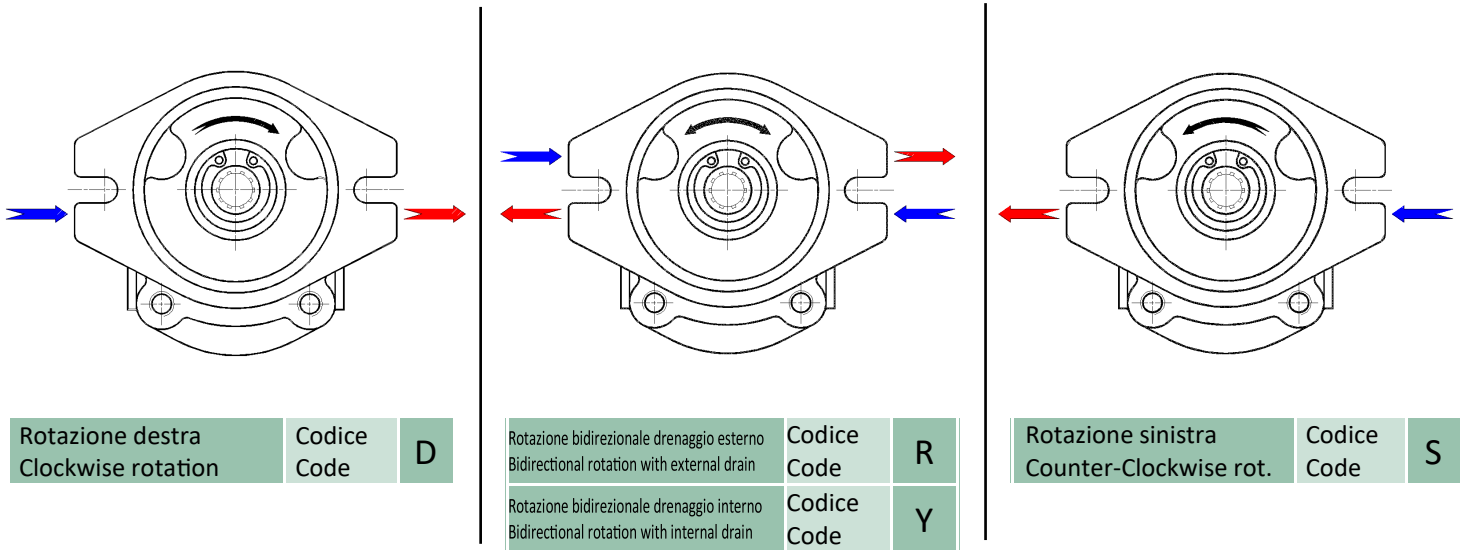

GUARNIZIONI PER ALBERI

SHAFT SEAL

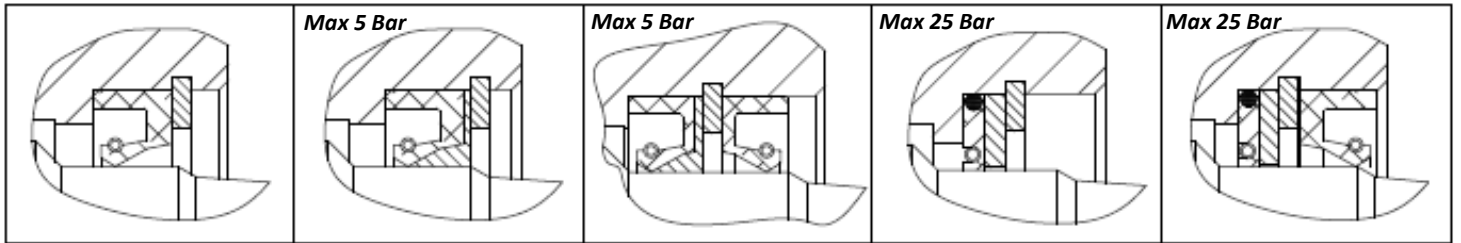

Codice Code	N	NBR	Codice Code	R	NBR	Codice Code	N2	NBR	Codice Code	B	//	Codice Code	BN	NBR
	V	FKM		RV	FKM		V2	FKM					BV	FKM
	H	HNBR		RH	HNBR									

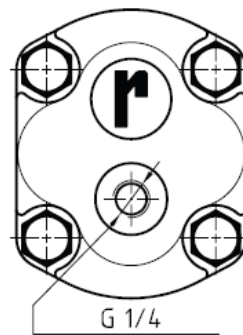
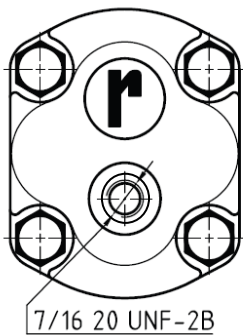

Drenaggio per pompe con flange
Drain for pumps with flanges

C4 - H6 - C7

Drenaggio per pompe con flange
Drain for pumps with flanges

A0 - B1 - D3 - D2 - M3 - M2 - E2 - F5 - L3

CAMBIO DEL SENSO DI ROTAZIONE DELLE POMPE Z2 CHANGING ROTATION OF THE PUMP Z2

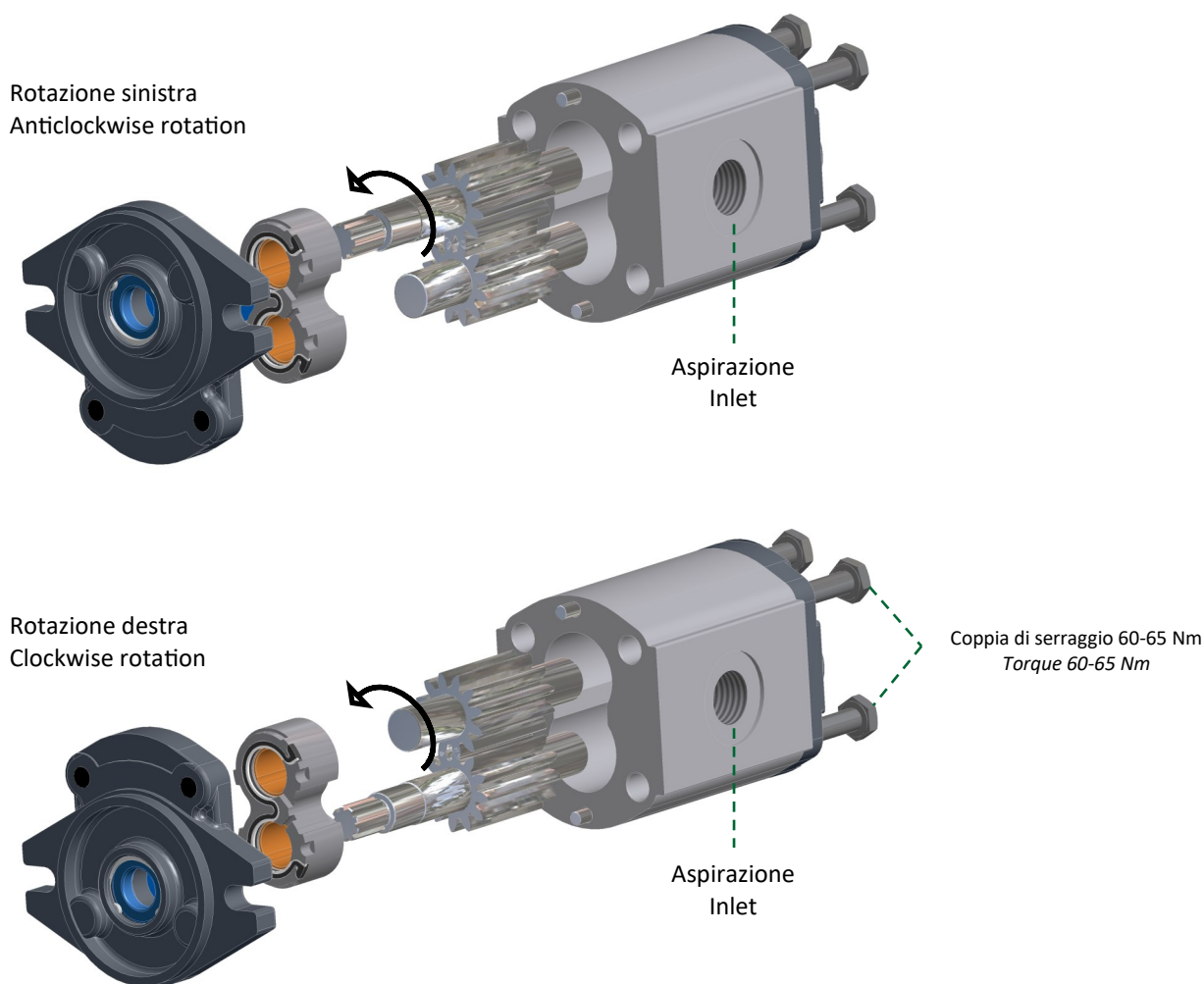

Il senso di rotazione è indicato con una freccia sul corpo della pompa.
An arrow on the housing of the pump indicates the rotation.

- Svitare le viti di fissaggio.
- Rimuovere la flangia tenendo premuto l'ingranaggio conduttore.
- Rimuovere contemporaneamente l'ingranaggio conduttore e il rasamento superiore mantenendo premuto l'ingranaggio condotto.
- Estrarre l'ingranaggio condotto tenendo fermo il rasamento inferiore, nel caso aiutarsi con una barretta NON metallica.
- Rimontare i due ingranaggi con posizioni invertite (vedi schema sopra).
- Rimontare il rasamento superiore facendo attenzione a NON invertirne la posizione.
- Rimontare la flangia utilizzando per le viti una coppia di serraggio di 60-65 Nm.

-
- *Unscrew the clamping bolts.*
 - *Remove the flange holding down the drive gear.*
 - *Remove the drive gear and the bushing block holding down the idle gear.*
 - *Remove the idle gear keeping down the rear bushing block with a no-metallic bar.*
 - *Reverse the position of the two gears (see picture above).*
 - *Replace the bushing block without rotating or changing position.*
 - *Reverse the flange and retighten the bolts to a torque rating between 44-48 ft/lbs.*

FLANGE
FLANGES

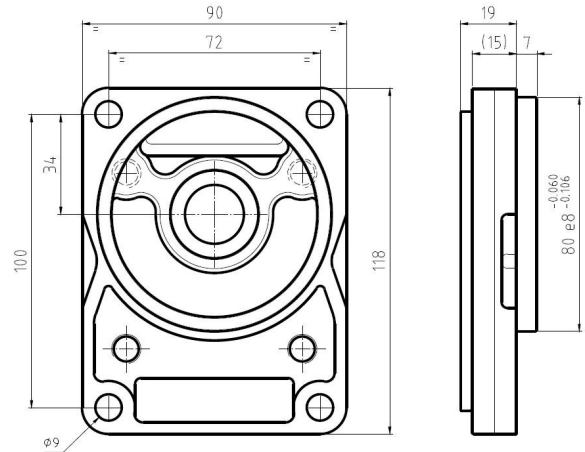
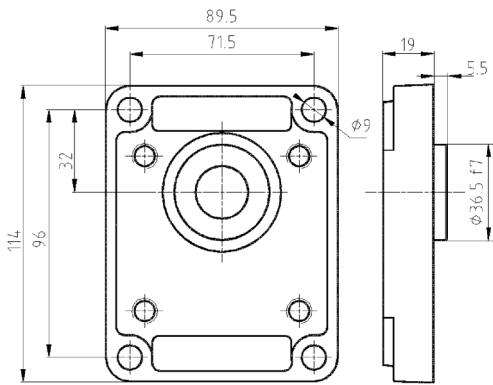

CODICE
CODE

A 0

NOTA: Materiale Ghisa
NOTE: Material Cast iron

CODICE
CODE

B 1

NOTA: Materiale Ghisa
NOTE: Material Cast iron

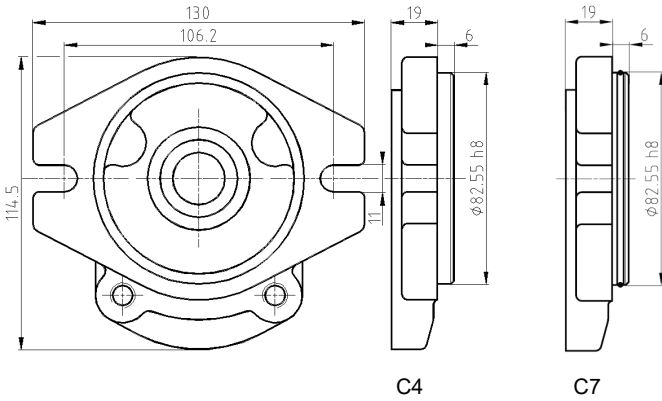

C4

C7

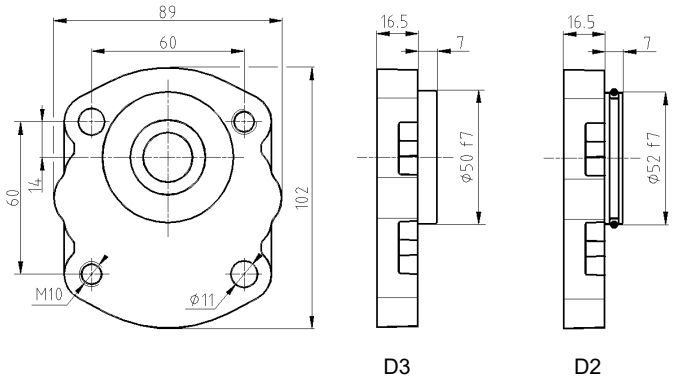

D3

D2

CODICE
CODE

C 4

NOTA: Materiale Ghisa
NOTE: Material Cast iron

C 7

CODICE
CODE

D 3

NOTA: Materiale Ghisa
NOTE: Material Cast iron

D 2

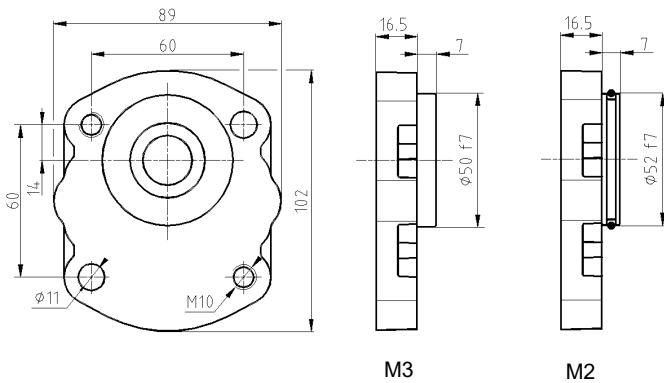

M3

M2

CODICE
CODE

M 3

NOTA: Materiale Ghisa
NOTE: Material Cast iron

M 2

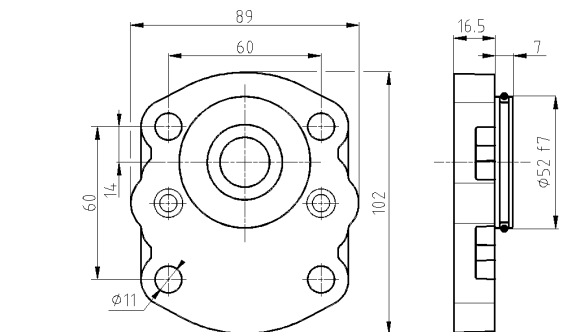

CODICE
CODE

E 2

NOTA: Materiale Ghisa
NOTE: Material Cast iron

FLANGE
FLANGES

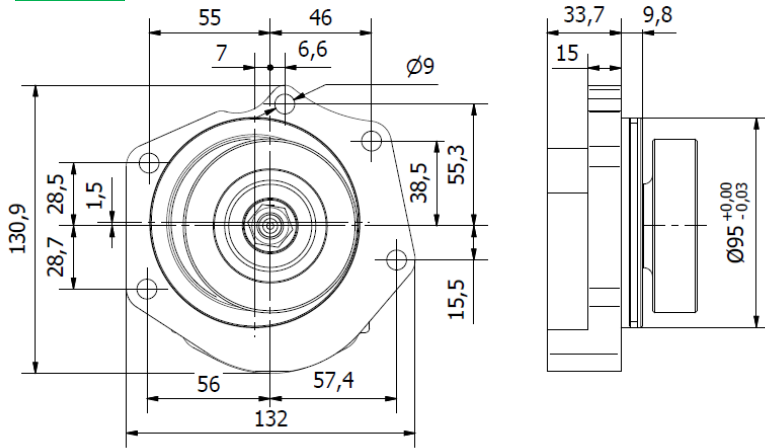

CODICE
CODE

K 7

NOTA: Materiale Ghisa
NOTE: Material Cast iron

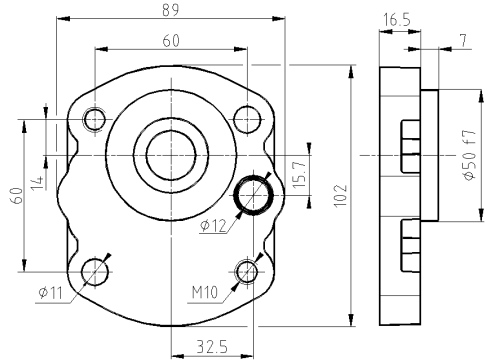

Rotazione destra
CW rotation

CODICE
CODE

G 3

NOTA: Materiale Ghisa
NOTE: Material Cast iron

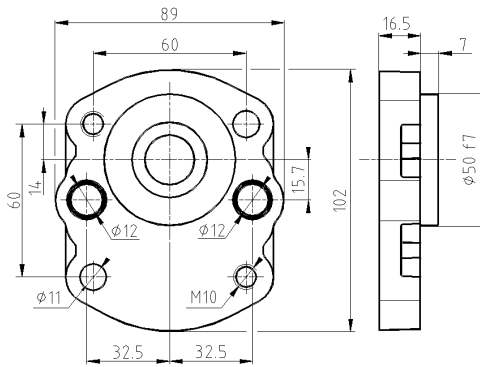

CODICE
CODE

L 3

NOTA: Materiale Ghisa
NOTE: Material Cast iron

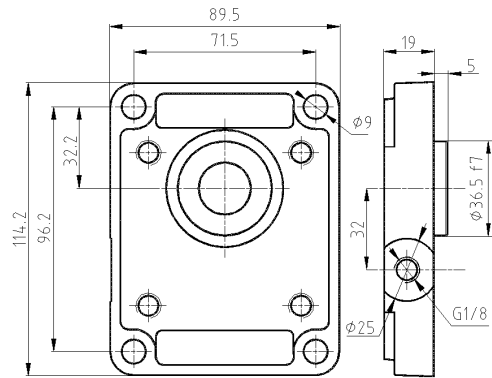

CODICE
CODE

N 4

NOTA: Materiale Ghisa
NOTE: Material Cast iron

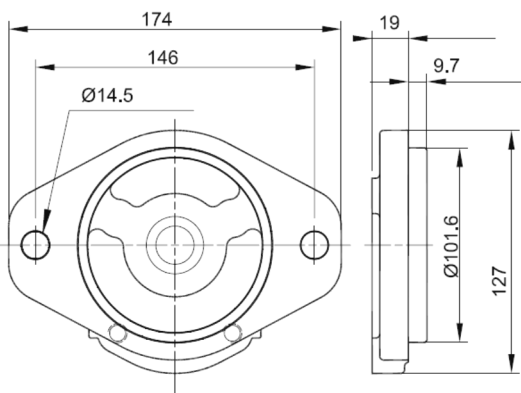

CODICE
CODE

H 6

NOTA: Materiale Ghisa
NOTE: Material Cast iron

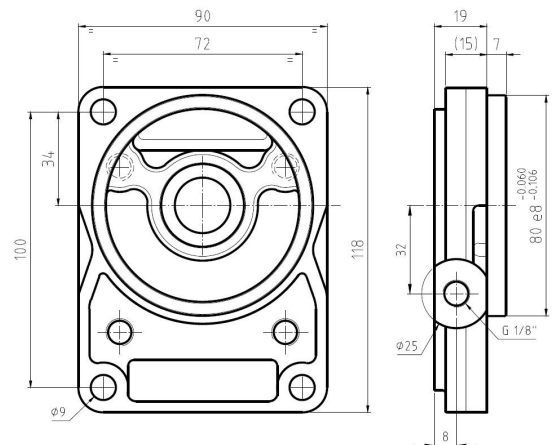

CODICE
CODE

P 1

NOTA: Materiale Ghisa
NOTE: Material Cast iron

ALBERI
SHAFTS

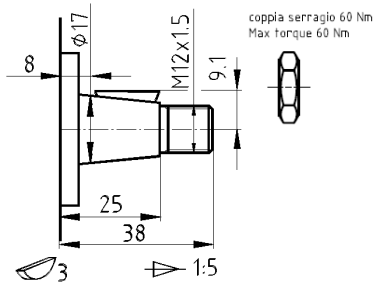

CODICE / CODE	A
PER FLANGIA / FOR FLANGE	B 1

Coppia max 140 Nm
Max torque 140 Nm

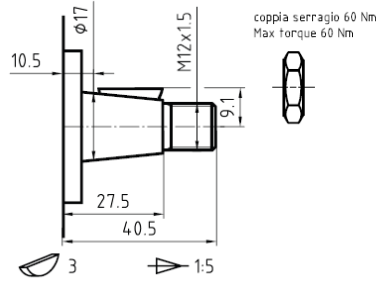

CODICE / CODE	A
PER FLANGIA / FOR FLANGE	D 3
	L 3
	M 3

Coppia max 140 Nm
Max torque 140 Nm

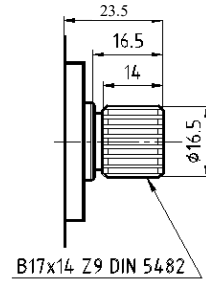

CODICE / CODE	B
PER FLANGIA / FOR FLANGE	B 1
	A 0

Coppia max 110 Nm
Max torque 110 Nm

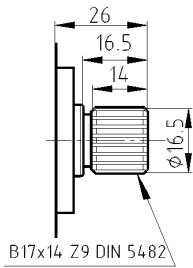

CODICE / CODE	B
PER FLANGIA / FOR FLANGE	D 3
	L 3
	M 3

Coppia max 110 Nm
Max torque 110 Nm

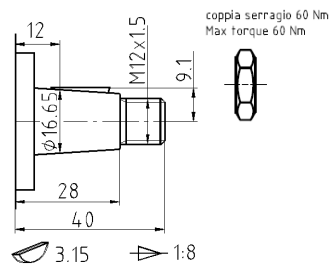

CODICE / CODE	C
PER FLANGIA / FOR FLANGE	A 0

Coppia max 150 Nm
Max torque 150 Nm

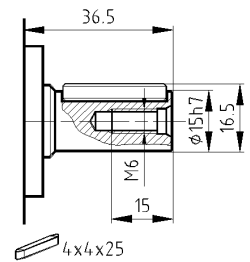

CODICE / CODE	E
PER FLANGIA / FOR FLANGE	A 0

Coppia max 70 Nm
Max torque 70 Nm

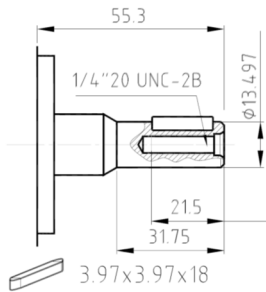

CODICE / CODE	H
PER FLANGIA / FOR FLANGE	C 4

Coppia max 60 Nm
Max torque 60 Nm

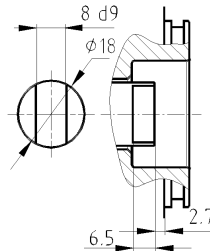

CODICE / CODE	F
PER FLANGIA / FOR FLANGE	E 2

Coppia max 75 Nm
Max torque 75 Nm

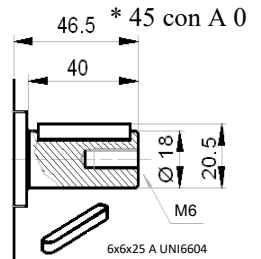

CODICE / CODE	G
PER FLANGIA / FOR FLANGE	B 1

Coppia max 85 Nm
Max torque 85 Nm

SOLO CON SUPPORTI INTEGRATI TIPO 1
WITH OUTBOARD BEARING TYPE 1

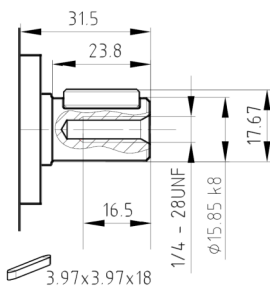

CODICE / CODE	L
PER FLANGIA / FOR FLANGE	C 4

Coppia max 75 Nm
Max torque 75 Nm

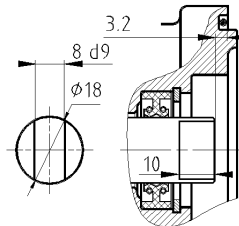

CODICE / CODE	M
PER FLANGIA / FOR FLANGE	F 5

Coppia max 75 Nm
Max torque 75 Nm

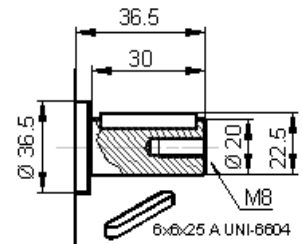

CODICE / CODE	I
PER FLANGIA / FOR FLANGE	A 0

Coppia max 100 Nm
Max torque 100 Nm

SOLO CON SUPPORTI INTEGRATI TIPO 1
WITH OUTBOARD BEARING TYPE 1

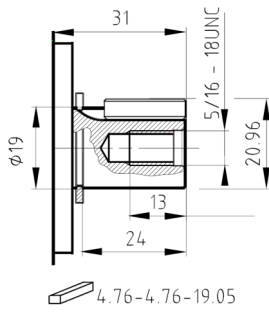

CODICE / CODE	N
PER FLANGIA / FOR FLANGE	C 4
Coppia max 110 Nm Max torque 110 Nm	C 7
	H 6

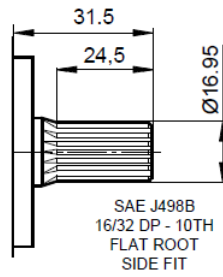

CODICE / CODE	W
PER FLANGIA / FOR FLANGE	C 4
Coppia max 130 Nm Max torque 130 Nm	C 7
	H 6

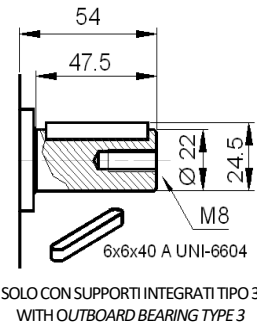

CODICE / CODE	Q
PER FLANGIA / FOR FLANGE	A 0
Coppia max 180 Nm Max torque 180 Nm	B 1
	B 2

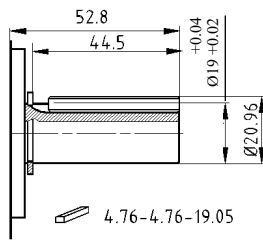

CODICE / CODE	R
PER FLANGIA / FOR FLANGE	C 4
Coppia max 140 Nm Max torque 140 Nm	C 7
	H 6

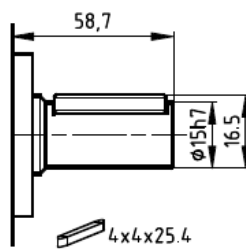

CODICE / CODE	LA
PER FLANGIA / FOR FLANGE	C 4
Coppia max 75 Nm Max torque 75 Nm	C 7

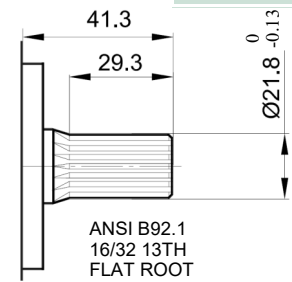

CODICE / CODE	T
PER FLANGIA / FOR FLANGE	C 4
Coppia max 280 Nm Max torque 280 Nm	C 7
	H 6

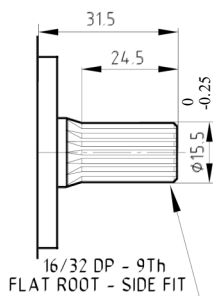

CODICE / CODE	U
PER FLANGIA / FOR FLANGE	C 4
Coppia max 130 Nm Max torque 130 Nm	C 7
	H 6

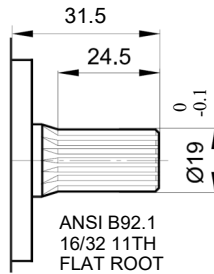

CODICE / CODE	K
PER FLANGIA / FOR FLANGE	C 4
Coppia max 200 Nm Max torque 200 Nm	C 7
	H 6

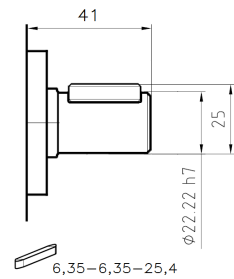

CODICE / CODE	V
PER FLANGIA / FOR FLANGE	C 4
Coppia max 190 Nm Max torque 190 Nm	C 7
	H 6

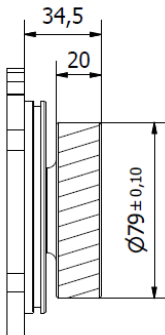

CODICE / CODE	J
PER FLANGIA / FOR FLANGE	K 7
Coppia max 140 Nm Max torque 140 Nm	

BOCCHIE DI ASPIRAZIONE E MANDATA LATERALI

SIDE INLET AND OUTLET PORTS

ASPIRAZIONE
INLET

MANDATA
OUTLET

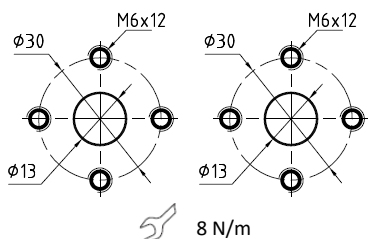

CODICE
CODE

32

ASPIRAZIONE
INLET

MANDATA
OUTLET

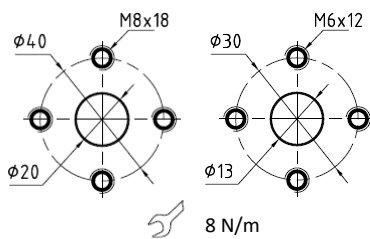

CODICE
CODE

33

ASPIRAZIONE
INLET

MANDATA
OUTLET

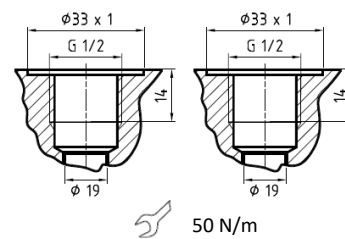

CODICE
CODE

34

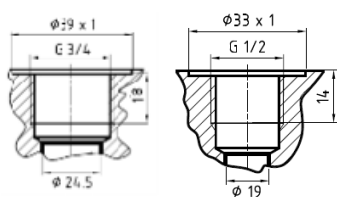

90 N/m - 50 N/m

CODICE
CODE

35

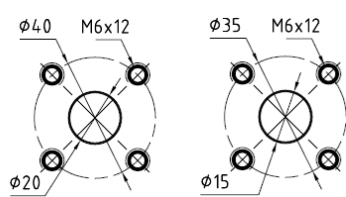

CODICE
CODE

36

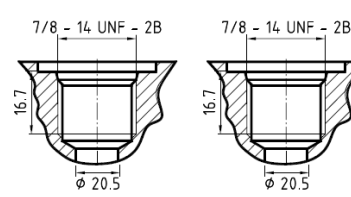

60 N/m

CODICE
CODE

37

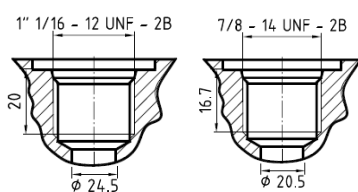

120 N/m - 70 N7m

CODICE
CODE

38

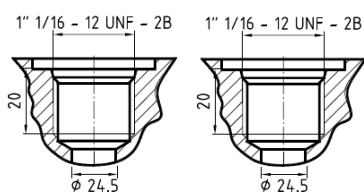

120 N/m

CODICE
CODE

39

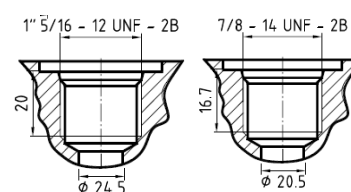

120 N/m - 70 N7m

CODICE
CODE

40

BOCCHIE DI ASPIRAZIONE E MANDATA LATERALI

SIDE INLET AND OUTLET PORTS

ASPIRAZIONE
INLET

MANDATA
OUTLET

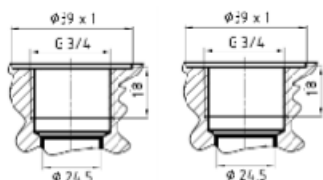

90 N/m

CODICE
CODE

41

ASPIRAZIONE
INLET

MANDATA
OUTLET

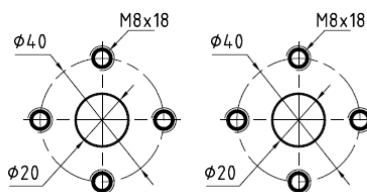

8 N/m

CODICE
CODE

43

ASPIRAZIONE
INLET

MANDATA
OUTLET

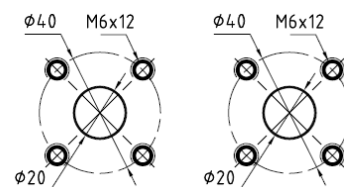

8 N/m

CODICE
CODE

44

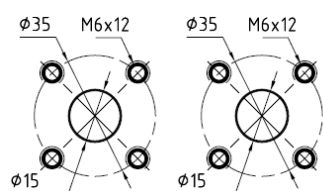

8 N/m

CODICE
CODE

55

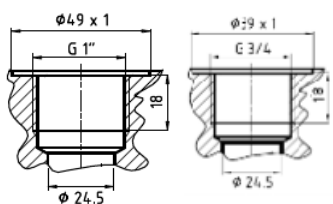

90 N/m

CODICE
CODE

42

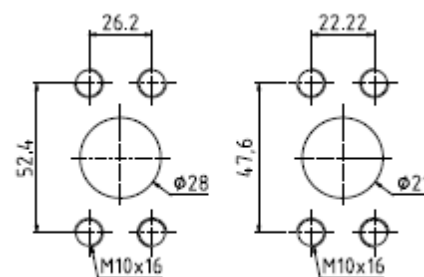

25 N/m

CODICE
CODE

24

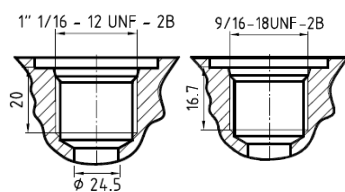

90 N/m

CODICE
CODE

57

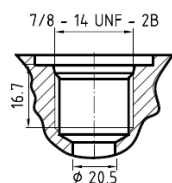

90 N/m

CODICE
CODE

58

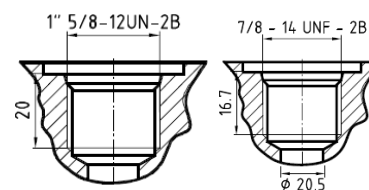

8 N/m

CODICE
CODE

59

SOLO PER ASPIRAZIONE COMUNE
ONLY FOR COMMON INLET

BOCCHIE DI ASPIRAZIONE E MANDATA LATERALI

SIDE INLET AND OUTLET PORTS

ASPIRAZIONE INLET	MANDATA OUTLET
----------------------	-------------------

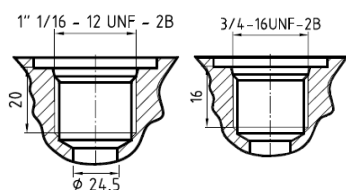

 90 N/m

CODICE CODE	67
----------------	-----------

ASPIRAZIONE INLET	MANDATA OUTLET
----------------------	-------------------

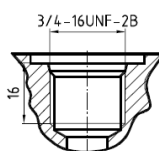

 70 N/m

CODICE CODE	70
----------------	-----------

SOLO PER ASPIRAZIONE COMUNE
ONLY FOR COMMON INLET

ASPIRAZIONE INLET	MANDATA OUTLET
----------------------	-------------------

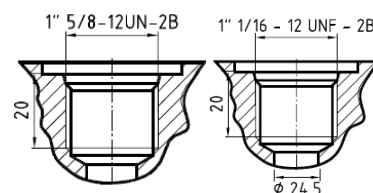

 90 N/m

CODICE CODE	15
----------------	-----------

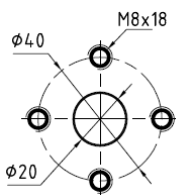

 8 N/m

CODICE CODE	71
----------------	-----------

SOLO PER ASPIRAZIONE COMUNE
ONLY FOR COMMON INLET

BOCCHIE DI ASPIRAZIONE E MANDATA ANTERIORI / POSTERIORI
FRONT AND REAR INLET AND OUTLET PORTS

ASPIRAZIONE INLET	MANDATA OUTLET
MANDATA OUTLET	ASPIRAZIONE INLET

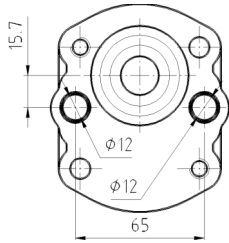

CODICE CODE	49
----------------	----

ASPIRAZIONE INLET	MANDATA OUTLET
----------------------	-------------------

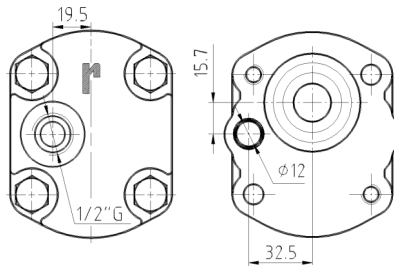

CODICE CODE	50
----------------	----

ASPIRAZIONE INLET	MANDATA OUTLET
----------------------	-------------------

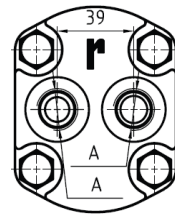

CODICE CODE	A
51	1/2" G
52	3/4" G
53	1 1/16-12 UN
54	7/8 - 14 UNF
56	3/4" G - 1/2" G
55	IN 1"1/16-12UN OUT 7/8"-14UNF
68	IN 1"1/16-12UN OUT 3/4"-16UNF

DIMENSIONI D'INGOMBRO
OVERALL DIMENSIONS

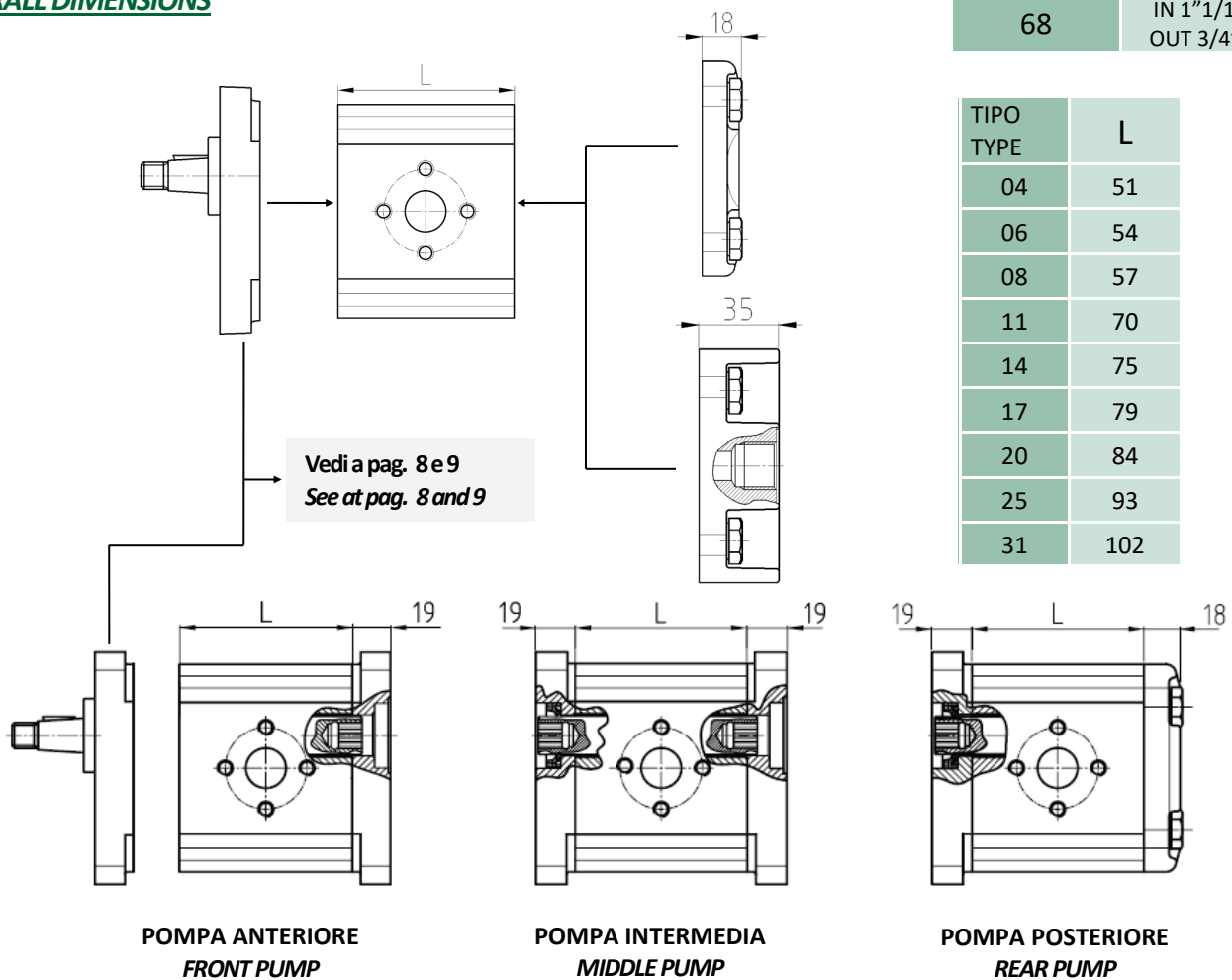

TIPO TYPE	L
04	51
06	54
08	57
11	70
14	75
17	79
20	84
25	93
31	102

SUPPORTI CON CUSCINETTI A DOPPIA CORONA DI SFERE VERSIONE 1
OUTBOARD BEARING TYPE 1

DISPONIBILE PER FLANGE
 AVAILABLE FOR FLANGE

A0 -B1 -C4

DISPONIBILE PER ALBERI
 AVAILABLE FOR SHAFT

A -G -I -R -T



DIAGRAMMA CARICHI RADIALI ED ASSIALI AMMISSIBILI
 GRAPHIC OF RADIAL AND AXIAL LOAD



Coppia massima di trascinamento 100 Nm
Max torque 100 Nm

DATI DI BASE PER STESURA GRAFICO

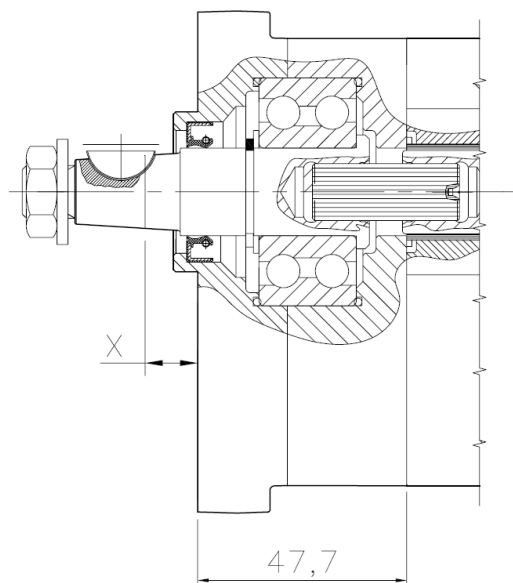
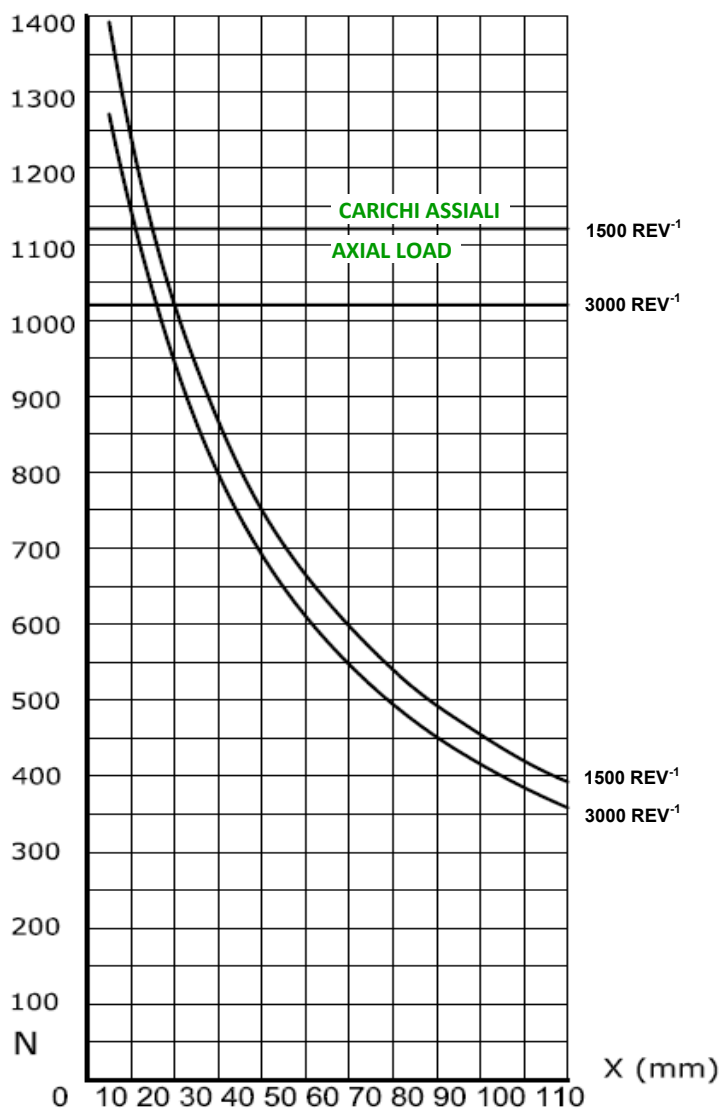
- Durata a fatica corretta 1000 h
- Olio VG-46
- Temperatura 60°C
- Affidabilità 90%
- Grado di contaminazione medio 10μ

IL VALORE DEI CARICHI E' INFLUENZATO DALLE CONDIZIONI DI FUNZIONAMENTO.

LOAD GRAPH

- Rating fatigue life 1000 h
- Oil type VG-46
- Temperature 60°C
- Trust 90%
- Contamination 10 μ

LOAD VALUE IS AFFECTED BY WORKING CONDITIONS.

SUPPORTI CON CUSCINETTI A DOPPIA CORONA DI SFERE VERSIONE 3
OUTBOARD BEARING TYPE 3

CARICO ASSIALE +2600N - 2600N
AXIAL LOAD +2600N - 2600N

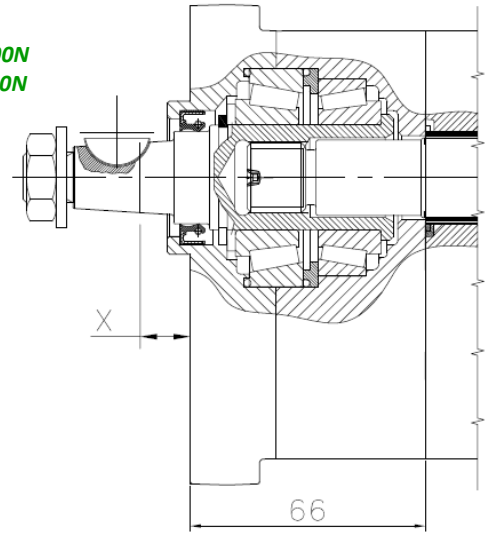

DISPONIBILE PER FLANGE
 AVAILABLE FOR FLANGE

A0 - B1 - C4 - N5

DISPONIBILE PER ALBERI
 AVAILABLE FOR SHAFT

A - G - Q - T

DIAGRAMMA CARICHI RADIALI AMMISSIBILI
GRAPHIC OF RADIAL LOAD

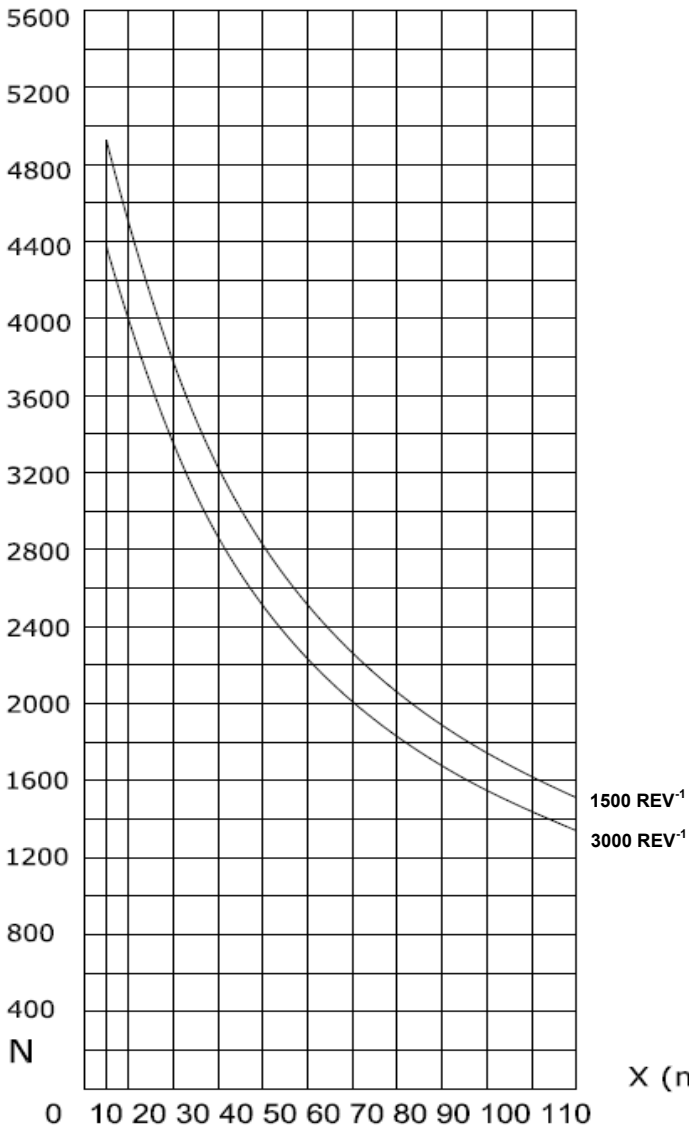

Coppia massima di trascinamento 175 Nm
Max torque 175 Nm

DATI DI BASE PER STESURA GRAFICO

- Durata a fatica corretta 1000 h
- Olio VG-46
- Temperatura 60°C
- Affidabilità 90%
- Grado di contaminazione medio 10μ

IL VALORE DEI CARICHI E' INFLUENZATO DALLE CONDIZIONI DI FUNZIONAMENTO

LOAD GRAPH

- Rating fatigue life 1000 h
- Oil type VG-46
- Temperature 60°C
- Trust 90%
- Contamination 10 μ

LOAD VALUE IS AFFECTED BY WORKING CONDITIONS

VALVOLA DI MASSIMA PRESSIONE RELIEF VALVE

VALVOLA A TARATURA REGOLABILE "VR" VALVE WITH ADJUSTABLE CALIBRATION "VR"

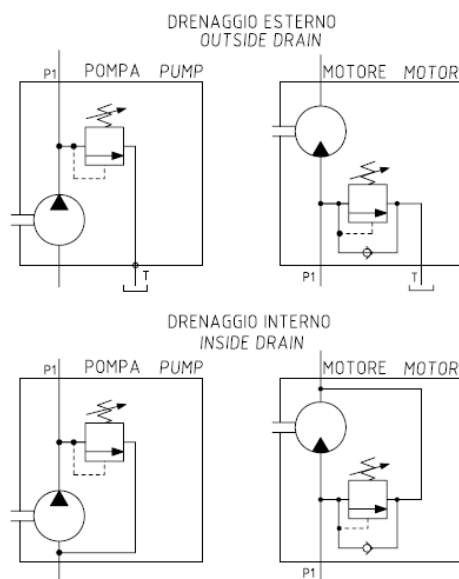
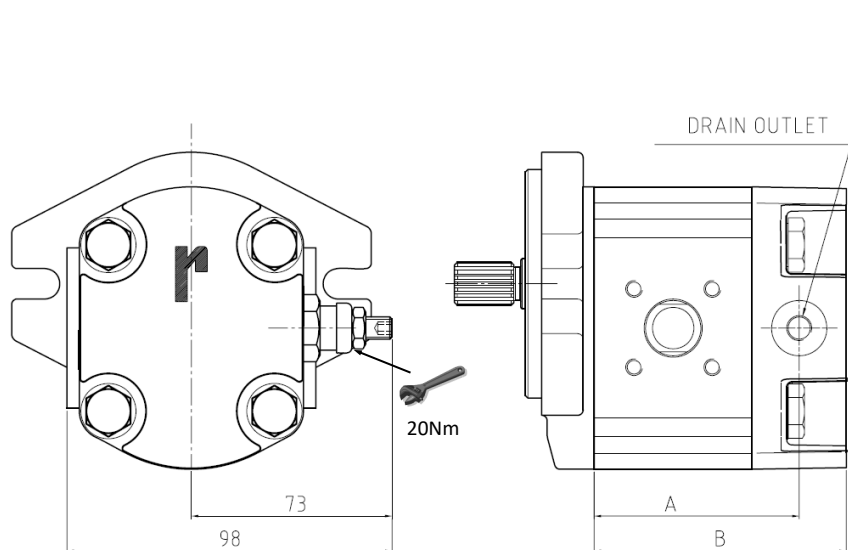

TYPE	04	06	08	11	14	17	20	25	31
A	86	89	92	105	110	114	119	128	137
B	66.5	69.5	72.5	85.5	90.5	94.5	99.5	108.5	117.5

Come ordinare/Ordering code

VRE: Valvola taratura regolabile, drenaggio esterno / Valve with adjustable calibration, external drain

VRI: Valvola taratura regolabile, drenaggio interno / Valve with adjustable calibration, internal drain

VALVOLA A TARATURA FISSA "VF" VALVE WITH FIXED CALIBRATION "VF"

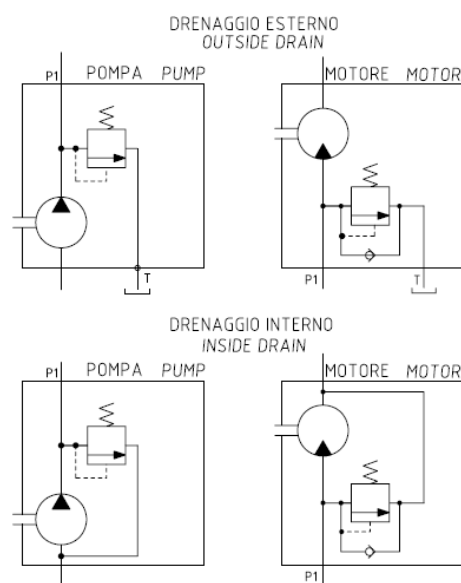
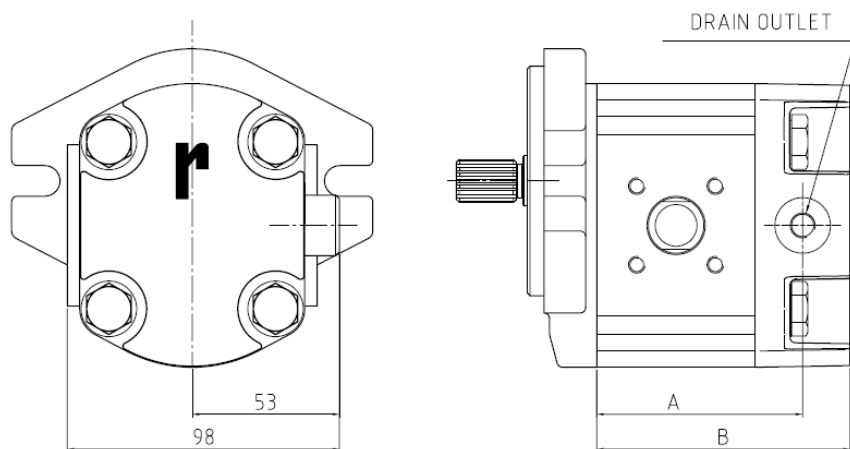

Come ordinare/Ordering code

VFE: Valvola taratura fissa, drenaggio esterno / Valve with fixed calibration, external drain.

VFI: Valvola taratura fissa, drenaggio interno / Valve with fixed calibration, internal drain.

ISTRUZIONI PER L'ORDINAZIONE DI UNITÁ SINGOLE Z2
HOW TO ORDER Z2 SINGLE UNITS

	1	2	3	4	5	6	7	8	9	10	11	12		
0	2	Z	A	G	06	E	0	34	S	-	0	B	VRE	210

1	TIPO UNITÁ / UNIT TYPE	CODICE / CODE
	PUMP	Z
	MOTOR	ZM

2-5	FLANGIA / FLANGE (PAG. 9-10)	CODICE / CODE
	EUROPA / EUROPEAN	A - 0
	TEDESCA / GERMAN	B - 1
	AMERICANA / AMERICAN	C - 4 / C - 7
	TEDESCA / GERMAN	D - 3 / D - 2
	TEDESCA / GERMAN	M - 3 / M - 2
	TEDESCA / GERMAN	E - 2
	MOTORE ENDOTERMICO / PETROL ENGINE	K - 7
	TEDESCA / GERMAN	G - 3
	TEDESCA / GERMAN	L - 3
	EUROPEA CON DRENAGGIO / EUROPEAN WITH DRAIN	N - 4
	AMERICANA / AMERICAN	H - 6
	TEDESCA CON DRENAGGIO / GERMAN WITH DRAIN	P - 1

3	CILINDRATA / CAPACITY cm ³	CODICE / CODE
	4.4	04
	6.3	06
	8.15	08
	11.3	11
	14.5	14
	16.9	17
	20.1	20
	25.7	25
	31.4	31

4	ALBERO / SHAFT (PAG. 11-12)	CODICE / CODE
	CONICO 1:5 / TAPERED 1:5	A
	17 x 14 DIN 5482	B
	CONICO 1:8 / TAPERED 1:8	C
	CILINDRICO Ø 15 / STRAIGHT Ø 15	E
	CILINDRICO Ø 13 / STRAIGHT Ø 13	H
	PENNA / TONGUE Ø18 x 8	F
	CILINDRICO Ø18 / STRAIGHT Ø18	G
	CILINDRICO Ø 15.85 / STRAIGHT Ø 15.85	L
	PENNA / TONGUE Ø18 x 8	M
	CILINDRICO Ø 20 / STRAIGHT Ø 20	I
	CILINDRICO Ø 19 / STRAIGHT Ø 19	N
	ANSI 921 10TH 16/32 FLAT ROOT	W
	CILINDRICO Ø 22 / STRAIGHT Ø 22	Q
	CILINDRICO Ø 19x45 / STRAIGHT Ø 19x45	R
	CILINDRICO Ø 15.85x58,7 / STRAIGHT Ø 15.85x58,7	LA
	34 TEETH LEFT HAND HELICAL GEAR	J

	ANSI 921 13 TH 16/32 FLAT ROOT	T
	ANSI 921 9 TH 16/32 FLAT ROOT	U
	ANSI 921 11 TH 16/32 FLAT ROOT	K
	CILINDRICO Ø 22.22 / STRAIGHT Ø 22.22	V

6	BOCCHIE / PORTS (PAG.13)	CODICE / CODE
	EUROPEE / EUROPEAN	32 - 33 - 43
	TEDESCHE / GERMAN	36 - 44 - 55
	BSPP	34 - 35 - 41 - 42
	O-RING BOSS	37 - 38 - 39 - 40
	PORTE ANTERIORI-POSTERIORI / FRONT-REAR PORTS	49 - 50 - 51 - 52 - 53 - 54 - 56

7	ROTAZIONE / ROTATION	CODICE / CODE
	DESTRO / RIGHT	D
	SINISTRO / LEFT	S
	BIDIRECTIONAL WITH INTERNAL DRAIN	Y
	BIDIRECTIONAL WITH EXTERNAL DRAIN	R

8	TIPO UNITÁ / UNIT TYPE	CODICE / CODE
	PREDISPOSTA TANDEM / FOR TANDEM	T
	NIENTE / NONE	-

9	SUPPORTI / SUPPORT (PAG. 15 - 16)	CODICE / CODE
	SENZA / WITHOUT	0
	CUSCINETTO A DOPPIA CORONA DI SFERE	1
	DOPPIO CUSCINETTO A RULLI CONICI	2
	DOPPIO CUSCINETTO A RULLI CONICI	3

10	PARAOILIO / SHAFT SEAL (PAG. 7)	CODICE / CODE
	STANDARD / STANDARD	N
	STANDARD FKM / STANDARD FKM	V
	STANDARD HNBR / STANDARD HNBR	H
	5 BAR NBR / 5 BAR NBR	R
	5 BAR FKM / 5 BAR FKM	RV
	5 BAR HNBR / 5 BAR HNBR	RH
	DOPPIO MIM NBR / DOUBLE SEAL NBR	N2
	DOPPIO MIM FKM / DOUBLE SEAL FKM	V2
	25 BAR VARISEAL NBR / 25 BAR VARISEAL NBR	B
	25 BAR NBR / 25 BAR NBR	BN
	25 BAR FKM / 25 BAR FKM	BV

11	VALVOLA DI MASSIMA / RELIEF VALVE	CODICE / CODE
	SENZA / WITHOUT	-
	TARATURA REGOLABILE / ADJUST. CALIBRATION	VRE / VRI
	TARATURA FISSA / FIXED CALIBRATION	VFE / VFI

12	VALORI TARATURA VALVOLA	CODICE / CODE
	50 - 75 - 100 - 125 - 150 - 200 - 250 - 300 - 330	

KIT DI MONTAGGIO POMPE MULTIPLE Z2 CON STADI A FLUSSI SEPARATI ASSEMBLING KITS FOR MULTIPLE PUMPS Z2 WITH SEPARATED FLOW

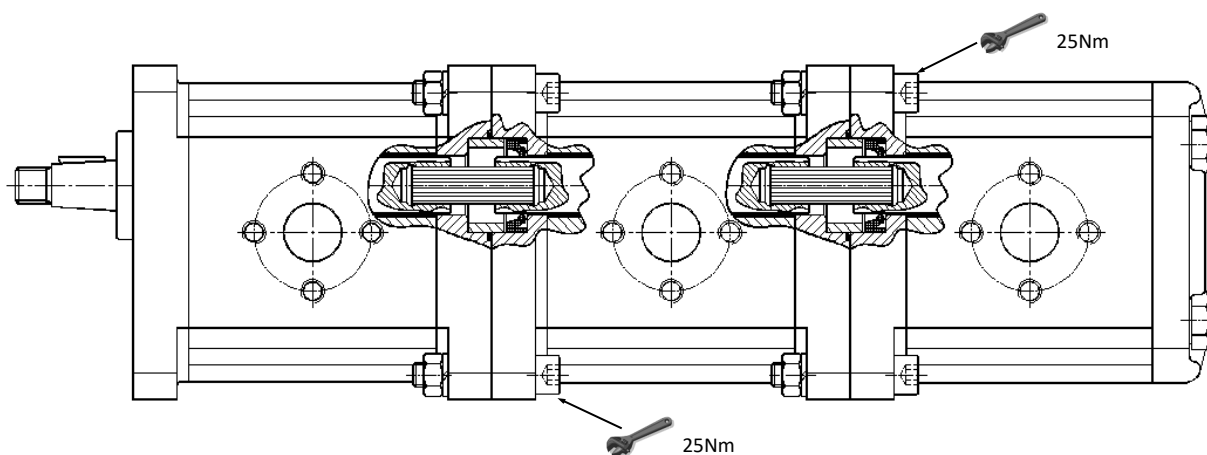

Cm ³ / giro Cm ³ / rev	+	Cm ³ / giro Cm ³ / rev	Codice Kit Code Kit
31-25-20-17-14-11		31-25-20-17-14-11	K2000000
8-6-4		8-6-4	K2000002

La pressione delle pompe intermedie e posteriori è limitata dalla tenuta dell'albero Z=25. La coppia max è **100 Nm**.

*Max. shaft loading must conform to the limitations of shaft Z=25. Max torque is **100 Nm**.*

Ref	PARTI PARTS
1	M8 x 40 UNI 5931
2	OR 2125
3	Bussola di centraggio Pilot ring
4	Rosetta Washer
5	Dado M8 Stud nut M8
6	Albero Z=25 Splined shaft Z=25

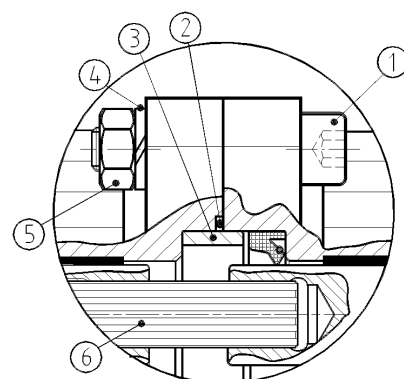

KIT DI MONTAGGIO POMPE MULTIPLE Z2-Z1 ASSEMBLING KITS FOR MULTIPLE PUMPS Z2-Z1

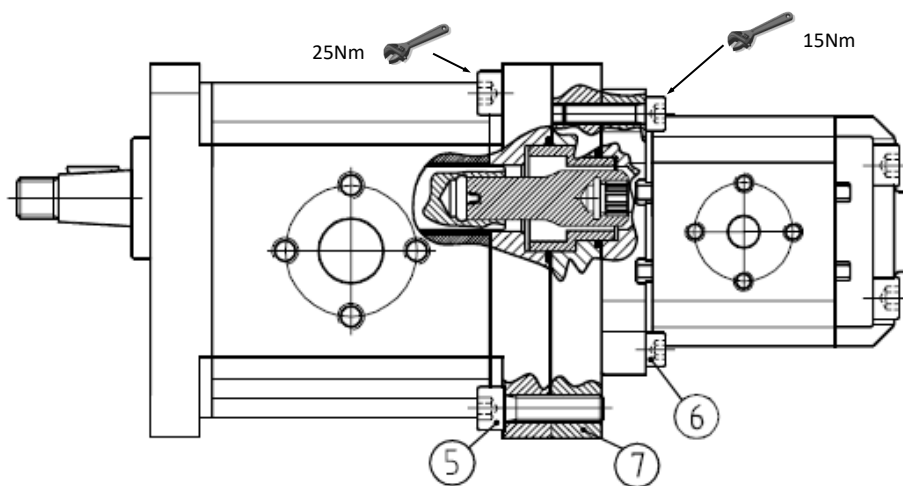

Pompa Z2 + Z1 tutti i tipi Pump Z2 + Z1 all of type		Codice Kit Code Kit
Tipo Type	31-25-20-17-14-11	K2000003
Tipo Type	8-6-4	K2000004

Ref	PARTI / PARTS
1	OR 2100
2	OR 2125
3	Bussola di centraggio / Pilot ring
4	Mozzo Z2-12x9 / Coupling Z2-12x9
5	M8 x 30 UNI 5931
6	M6 x 25 UNI 5931
7	Piastra collegamento / Connection plate

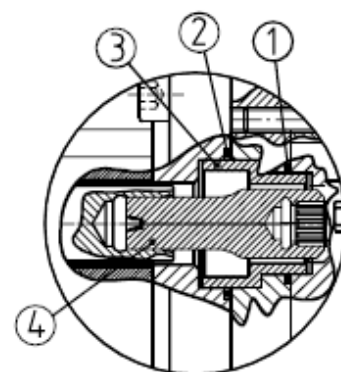

ISTRUZIONI PER ORDINARE UNITÁ MULTIPLE Z2

HOW TO ORDER Z2 MULTIPLE UNITS

			1		2	3	4	5		6	7	8	
0	2	Z	A	G	06	E	0	34	A	S	B	0	POMPA ANTERIORE FRONT PUMP

	*				2*			5*		6	7		
0	2	Z	A	G	06	0	0	34	I	S	B		POMPA INTERMEDIA Z2 o Z1 MIDDLE PUMP Z2 or Z1

	*				2*			5*		6	7		
0	2	Z	A	G	06	0	0	34	P	S	B		POMPA POSTERIORE Z2 o Z1 REAR PUMP Z2 or Z1

* Per tandem con pompe Z1 consultare il relativo catalogo.

* For tandem with Z1 pumps please check relative catalogue.

1 - 4	FLANGIA / FLANGE (PAG. 9-10)	CODICE / CODE
	EUROPA / EUROPEAN	A - 0
	TEDESCA / GERMAN	B - 1
	AMERICANA / AMERICAN	C - 4 / C - 7
	TEDESCA / GERMAN	D - 3 / D - 2
	TEDESCA / GERMAN	M - 3 / M - 2
	TEDESCA / GERMAN	E - 2
	MOTORE ENDOTERMICO / PETROL ENGINE	K - 7
	TEDESCA / GERMAN	G - 3
	TEDESCA / GERMAN	L - 3
	EUROPEA CON DRENAGGIO / EUROPEAN WITH DRAIN	N - 4
	AMERICANA / AMERICAN	H - 6
	TEDESCA CON DRENAGGIO / GERMAN WITH DRAIN	P - 1

2	CILINDRATA / CAPACITY cm ³	CODICE / CODE
	4.4	04
	6.3	06
	8.15	08
	11.3	11
	14.5	14
	16.9	17
	20.1	20
	25.7	25
	31.4	31

5	BOCCHE / PORTS (PAG.13)	CODICE / CODE
	EUROPEE / EUROPEAN	32 - 33 - 43
	TEDESCHE / GERMAN	36 - 44 - 55
	BSPP	34 - 35 - 41 - 42
	O-RING BOSS	37 - 38 - 39 - 40
	PORTE ANTERIORI-POSTERIORI / FRONT-REAR PORTS	49 - 50 - 51 - 52 - 53 - 54 - 56

3	ALBERO / SHAFT (PAG. 11-12)	CODICE / CODE
	CONICO 1:5 / TAPERED 1:5	A
	17 x 14 DIN 5482	B
	CONICO 1:8 / TAPERED 1:8	C
	CILINDRICO Ø 15 / STRAIGHT Ø 15	E

	CILINDRICO Ø 13 / STRAIGHT Ø 13	H
	PENNA / TONGUE Ø18 x 8	F
	CILINDRICO Ø18 / STRAIGHT Ø18	G
	CILINDRICO Ø 15.85 / STRAIGHT Ø 15.85	L
	PENNA / TONGUE Ø18 x 8	M
	CILINDRICO Ø 20 / STRAIGHT Ø 20	I
	CILINDRICO Ø 19 / STRAIGHT Ø 19	N
	ANSI 921 10TH 16/32 FLAT ROOT	W
	CILINDRICO Ø 22 / STRAIGHT Ø 22	Q
	CILINDRICO Ø 19x45 / STRAIGHT Ø 19x45	R
	CILINDRICO Ø 15.85x58,7 / STRAIGHT Ø 15.85x58,7	LA
	34 TEETH LEFT HAND HELICAL GEAR	J
	ANSI 921 13 TH 16/32 FLAT ROOT	T
	ANSI 921 9 TH 16/32 FLAT ROOT	U
	ANSI 921 11 TH 16/32 FLAT ROOT	K
	CILINDRICO Ø 22.22 / STRAIGHT Ø 22.22	V

6	ROTAZIONE / ROTATION	CODICE / CODE
	DESTRO / RIGHT	D
	SINISTRO / LEFT	S

7	PARAOILIO / SHAFT SEAL (PAG. 7)	CODICE / CODE
	STANDARD / STANDARD	N
	STANDARD FKM / STANDARD FKM	V
	STANDARD HNBR / STANDARD HNBR	H
	5 BAR NBR / 5 BAR NBR	R
	5 BAR FKM / 5 BAR FKM	RV
	5 BAR HNBR / 5 BAR HNBR	RH
	DOPPIO MIM NBR / DOUBLE SEAL NBR	N2
	DOPPIO MIM FKM / DOUBLE SEAL FKM	V2
	25 BAR VARISEAL NBR / 25 BAR VARISEAL NBR	B
	25 BAR NBR / 25 BAR NBR	BN
	25 BAR FKM / 25 BAR FKM	BV

8	SUPPORTI / SUPPORT (PAG. 15-16)	CODICE / CODE
	SENZA / WITHOUT	0
	CUSCINETTO A DOPPIA CORONA DI SFERE	1
	DOPPIO CUSCINETTO A RULLI CONICI	2
	DOPPIO CUSCINETTO A RULLI CONICI	3

KIT DI MONTAGGIO POMPE MULTIPLE COMPATTE Z2 CON ENTRATA COMUNE O SEPARATA
ASSEMBLING KITS FOR MULTIPLE COMPACT PUMPS Z2 WITH COMMON OR SEPARATED INLET PORTS

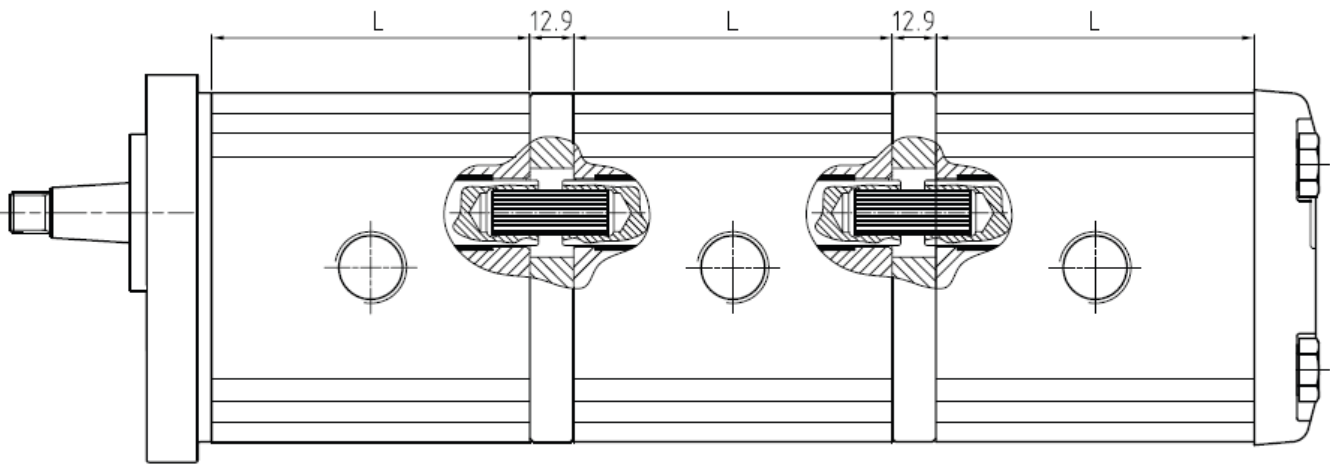

Cm ³ / giro Cm ³ / rev	+	Cm ³ / giro Cm ³ / rev	Codice Kit Code Kit
31-25-20-17-14-11		31-25-20-17-14-11	K2000006
31-25-20-17-14-11		8-6-4	K2000006
8-6-4		8-6-4	K2000008

La pressione delle pompe intermedie e posteriori è limitata dalla tenuta dell'albero Z=25. La coppia max è **100 Nm**.

*Max. shaft loading must conform to the limitations of shaft Z=25. Max torque is **100 Nm**.*

Ref	PARTI PARTS
1	Albero Z=25 Splined shaft Z=25
2	Flangia 95-144 Flange 95-144
3	OR 2.6 / 61.6

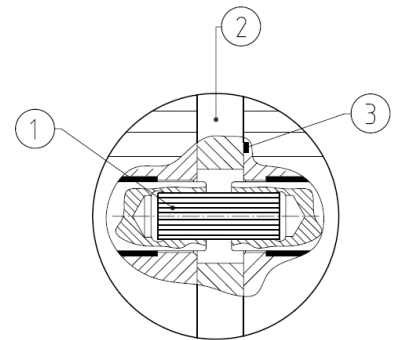

CODICI BOCHE PER POMPE MULTIPLE COMPATTE Z2 CON ASPIRAZIONE COMUNE O SEPARATA
PORTS CODE FOR MULTIPLE COMPACT PUMPS Z2 WITH COMMON INLET

PORTE GAS GAS PORTS			PORTE UNF UNF PORTS			PORTE FLANGIATE FLANGED PORTS		
ENTRATA INLET	USCITA OUTLET	CODICE CODE	ENTRATA INLET	USCITA OUTLET	CODICE CODE	ENTRATA INLET	USCITA OUTLET	CODICE CODE
//	1/2 G	01	//	7/8	11	//	13-30/M6	21
//	3/4 G	02	//	1" 1/16	12	//	15-35/M6	22
1" G	1/2 G	03	1" 5/16	7/8	13	27-55/M8	15-35/M6	23
1" G	3/4 G	04	1" 5/16	1" 1/16	14			
1" 1/4 G	3/4 G	05	1" 5/8	1" 1/16	15			
1" 1/2 G	3/4 G	06	1" 1/16	3/4"	16			

ISTRUZIONI PER ORDINARE POMPE MULTIPLE COMPATTE Z2

HOW TO ORDER MULTIPLE COMPACT PUMPS Z2

	1		2	3	4	5	6	7	8	9	10	11	12		
0	2	Z	A	G	06*	06*	06*	E	0	34*	34*	34*	S	R	0

ESEMPIO PER POMPA A TRE STADI
EXAMPLE FOR A PUMP WITH THREE STAGES

1-6	FLANGIA / FLANGE (PAG. 9-10)	CODICE / CODE
	EUROPA / EUROPEAN	A - 0
	TEDESCA / GERMAN	B - 1
	AMERICANA / AMERICAN	C - 4 / C - 7
	TEDESCA / GERMAN	D - 3 / D - 2
	TEDESCA / GERMAN	M - 3 / M - 2
	TEDESCA / GERMAN	E - 2
	MOTORE ENDOTERMICO / PETROL ENGINE	K - 7
	TEDESCA / GERMAN	G - 3
	TEDESCA / GERMAN	L - 3
	EUROPEA CON DRENAGGIO / EUROPEAN WITH DRAIN	N - 4
	AMERICANA / AMERICAN	H - 6
	TEDESCA CON DRENAGGIO / GERMAN WITH DRAIN	P - 1

2-3-4	CILINDRATA / CAPACITY cm ³	CODICE / CODE
	4.4	04
	6.3	06
	8.15	08
	11.3	11
	14.5	14
	16.9	17
	20.1	20
	25.7	25
	31.4	31

7-8-9	BOCCHIE / PORTS (PAG. 13-18-22)	CODICE / CODE
	EUROPEE / EUROPEAN	32 - 33 - 43 - 21
	TEDESCHE / GERMAN	36 - 44
	GAS	01 - 02 - 03 - 04 - 05 - 06 - 34 - 35 - 40
	SAE	11 - 12 - 13 - 14 - 15 - 37 - 38 - 39

5	ALBERO / SHAFT (PAG. 11-12)	CODICE / CODE
	CONICO 1:5 / TAPERED 1:5	A
	17 x 14 DIN 5482	B
	CONICO 1:8 / TAPERED 1:8	C
	CILINDRICO Ø 15 / STRAIGHT Ø 15	E
	CILINDRICO Ø 13 / STRAIGHT Ø 13	H

	PENNA / TONGUE Ø18 x 8	F
	CILINDRICO Ø18 / STRAIGHT Ø18	G
	CILINDRICO Ø 15.85 / STRAIGHT Ø 15.85	L
	PENNA / TONGUE Ø18 x 8	M
	CILINDRICO Ø 20 / STRAIGHT Ø 20	I
	CILINDRICO Ø 19 / STRAIGHT Ø 19	N
	ANSI 921 10TH 16/32 FLAT ROOT	W
	CILINDRICO Ø 22 / STRAIGHT Ø 22	Q
	CILINDRICO Ø 19x45 / STRAIGHT Ø 19x45	R
	CILINDRICO Ø 15.85x58,7 / STRAIGHT Ø 15.85x58,7	LA
	34 TEETH LEFT HAND HELICAL GEAR	J
	ANSI 921 13 TH 16/32 FLAT ROOT	T
	ANSI 921 9 TH 16/32 FLAT ROOT	U
	ANSI 921 11 TH 16/32 FLAT ROOT	K
	CILINDRICO Ø 22.22 / STRAIGHT Ø 22.22	V

10	ROTAZIONE / ROTATION	CODICE / CODE
	DESTRO / RIGHT	D
	SINISTRO / LEFT	S

11	PARAOILIO / SHAFT SEAL (PAG. 7)	CODICE / CODE
	STANDARD / STANDARD	N
	STANDARD FKM / STANDARD FKM	V
	STANDARD HNBR / STANDARD HNBR	H
	5 BAR NBR / 5 BAR NBR	R
	5 BAR FKM / 5 BAR FKM	RV
	5 BAR HNBR / 5 BAR HNBR	RH
	DOPPIO MIM NBR / DOUBLE SEAL NBR	N2
	DOPPIO MIM FKM / DOUBLE SEAL FKM	V2
	25 BAR VARISEAL NBR / 25 BAR VARISEAL NBR	B
	25 BAR NBR / 25 BAR NBR	BN
	25 BAR FKM / 25 BAR FKM	BV

12	SUPPORTI / SUPPORT (PAG. 15-16)	CODICE / CODE
	SENZA / WITHOUT	0
	CUSCINETTO A DOPPIA CORONA DI SFERE	1
	DOPPIO CUSCINETTO A RULLI CONICI	2
	DOPPIO CUSCINETTO A RULLI CONICI	3

* INSERIRE NEL CODICE IL VALORE DELLA CILINDRATA PER LA POMPA DESIDERATA.
INSERT THE CAPACITY FOR THE DESIRED PUMP.

Ronzio Oleodinamica si riserva di apportare in qualunque momento modifiche ai modelli descritti sia per ragioni di natura tecnica che commerciale.
Riproduzione vietata.

Ronzio Oleodinamica reserves the right to make change to the product described here in any time it deems fit in relation to technical or commercial requirements.



VIALE INDUSTRIA 37/39, 20010 BOFFALORA TICINO -MI- ITALY
TEL. +39 02 9754057 FAX +39 02 97255070
E-mail sales@ronzio.com - www.ronzio.com