

Axial piston pumps type PVPC

variable displacement, high pressure operation

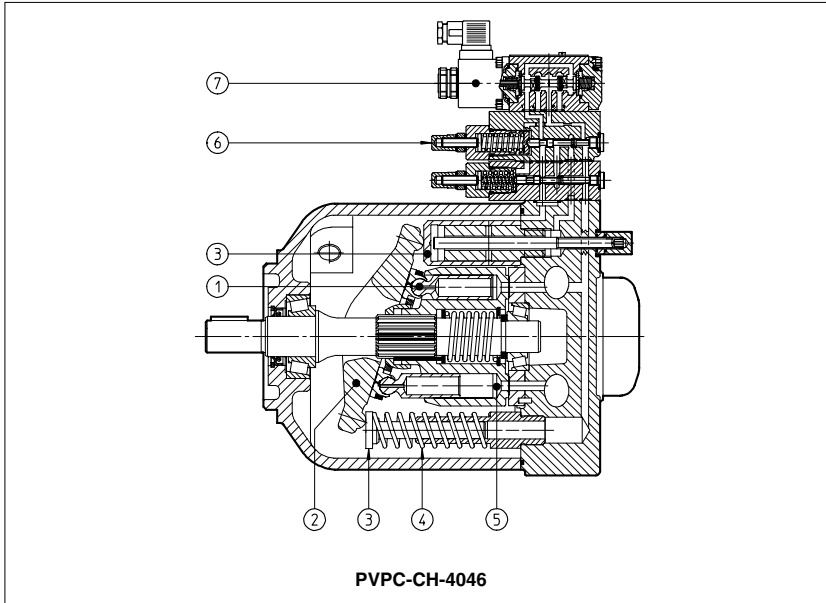

PVPC are variable displacement axial piston pumps for high pressure operation, with low noise level, suitable for hydraulic oils or synthetic fluids having similar lubricating characteristics. The actual displacement is dependent on the length of stroke of the pumping pistons (1). This length of stroke is determined by the position of the swashing plate (2) that is achieved by two servo pistons (3) with differential areas, against a spring (4). The rotating barrel (5) forces the pistons in a circular path in and out of the barrel and fluid displacement takes place. Typical section on side shows version CH with manual pressure compensator (4) and venting solenoid valve (7). The available hydraulic controls are shown in sections (7). The wide range of electrohydraulic proportional controls is shown in tab. A170. SAE J744 mounting flange and shaft (see note 1).
 Max displacement: 29-46-73 cm³/rev.
 Max pressure: 280 bar working
 350 bar peak.

1 MODEL CODE

PVPC	X2E - C	4 - 046 / 31044 / 1	D - I	X	24DC	10	/*
Variable displacement axial piston pump	Eventual suffix for double pumps X2E = with a fixed displacement pump type PFE (see tab. A005)	Type of control (see section 7): C = manual pressure compensator CH = manual pressure compensator, with venting R = remote pressure compensator L = load sensing (pressure & flow) LW = constant power (combined pressure & flow) For electrohydraulic proportional controls, see table A170	Size: 3 = for displacement 029 4 = for displacement 046 5 = for displacement 073	Max displacement of axial piston pump: 029 = 29 cm ³ /rev 046 = 46 cm ³ /rev 073 = 73 cm ³ /rev	Synthetic fluids: WG = water-glycol PE = phosphate ester See notes under section 2	Design number	Supply voltage, see section 5: 00 = solenoid valve without coils (only for OI solenoid)
Type of PFE (for double pumps), see tab. A005				X = without connector See section 4 for available connectors, to be ordered separately			
1) pumps with ISO 3019/2 mounting flange and shaft (option /M) are available on request				Solenoid of pilot valve: -I = solenoid OI (DHI) for AC and DC supply			
				Direction of rotation (viewed at the shaft end) D = clockwise S = counterclockwise			
				Shaft (SAE Standard): 1 = keyed (7/8" for 029 - 1" for 046 - 1 1/4" for 073) 5 = splined (13 teeth for 029 - 15 for 046 - 14 for 073)			

2 OPERATING CHARACTERISTICS

Pump model		PVPC-*-3029		PVPC-*-4046		PVPC-*-5073	
		Type 1	Type 5	Type 1	Type 5	Type 1	Type 5
Displacement	[cm ³ /rev]	29		46		73	
Max flow at 1450 rpm and 7 bar	[l/min]	41		65		103	
Max working pressure / Peak pressure	[bar]	280/350		280/350		280/350	
Min/Max inlet pressure	[bar abs.]	0,8 / 25		0,8 / 25		0,8 / 25	
Max pressure on drain port	[bar abs.]	1,5		1,5		1,5	
Power consumption at 1450 rpm and at maximum pressure and displacement	[kW]	19,9		31,6		50,1	
Max torque on the first shaft	[Nm]	Type 1 155	Type 5 190	Type 1 220	Type 5 330	Type 1 400	Type 5 620
Max permissible load on drive shaft	[N]	$\frac{F_{ax}}{F_{rad}}$ 1000 1500		1500 1500		2000 3000	
Speed rating	[rpm]	600 ÷ 3000		600 ÷ 2600		600 ÷ 2200	

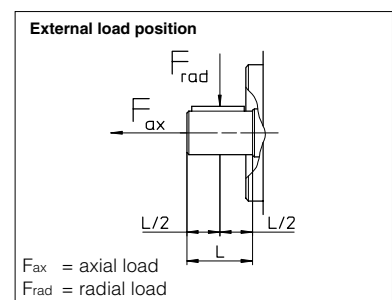

Notes: For speeds over 1800 rpm the inlet port must be under oil level with adequate pipes. Maximum pressure for all models with option /WG is 160 bar, with option /PE is 190 bar. Max speed with options /WG and /PE is 2000/1900/1600 rpm respectively for the three sizes.

3 MAIN CHARACTERISTICS OF VARIABLE DISPLACEMENT AXIAL PISTON PUMP TYPE PVPC

Installation position	Any position. The drain port must be on the top of the pump. Drain line must be separated and unrestricted to the reservoir and extended below the oil level as far from the inlet as possible. Suggested maximum line length is 3 m.
Ambient temperature	from -20°C to +70°C
Fluid	Hydraulic oil as per DIN 51524...535; for other fluids see section 11
Recommended viscosity	15÷100 mm ² /sec at 40°C (ISO VG 15÷100). Maximum start-up viscosity: 1000 mm ² /sec
Fluid contamination class	ISO 16/13 (filters at 10 µm value with β ₁₀ ≥ 75 recommended)
Fluid temperature	-20°C +60°C -20°C +50°C (seals /WG) -20°C +80°C (seals /PE)

3.1 Coils characteristics (for version CH)

Insulation class	H
Connector protection degree	IP 65
Relative duty factor	100%
Supply voltage and frequency	See electric feature 5
Supply voltage tolerance	± 10%

4 ELECTRIC CONNECTORS ACCORDING TO DIN 43650 FOR VERSION CH

The connectors must be ordered separately

Code of connector	Function
SP-666	Connector IP-65, suitable for direct connection to electric supply source
SP-667	As SP-666 connector IP-65 but with built-in signal led, suitable for direct connection to electric supply source

5 ELECTRIC FEATURES FOR VERSION CH

Type of solenoid	External supply nominal voltage ±10% (1)		Type of connector	Power consumption (3)	Code of spare coil	Colour of coil label
OI	DIRECT CURRENT	6 DC	SP-666 or SP-667	33 W	SP-COU-6DC /80 SP-COU-12DC /80 SP-COU-24DC /80 SP-COU-48DC /80	brown green red silver
		12 DC				
24 DC						
48 DC						
ALTERNATE CURRENT	110/50 AC (2)	SP-666 or SP-667	60 VA (4)	SP-COI-110/50/60AC /80 SP-COI-120/60AC /80 SP-COI-230/50/60AC /80 SP-COI-230/60AC /80	yellow white light blue silver	
	120/60 AC					
230/50 AC (2)						
230/60 AC						

(1) For other supply voltages available on request see technical table E010.

(2) Coil can be supplied also with 60 Hz of voltage frequency: in this case the performances are reduced by 10 ÷ 15% and the power consumption is 55 VA.

(3) Average values based on tests performed at nominal hydraulic condition and ambient/coil temperature of 20°C.

(4) When solenoid is energized, the inrush current is approx 3 times the holding current. Inrush current values correspond to a power consumption of about 150 VA.

6 DIAGRAMS at 1450 rpm (based on mineral oil ISO VG 46 at 50°C)

6.1 Noise level curves

The noise level has been measured in ambient conditions according to ISO 4412-1 standards.
 Distance from microphone to pump = 1 m.
 Measuring error = ± 2 dB
 — = Qmax - - - - - = Qmin

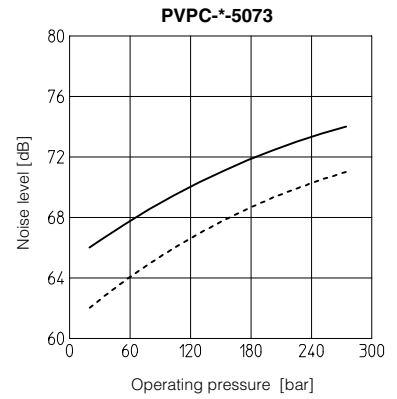
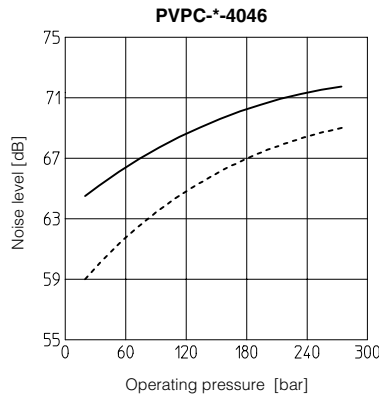
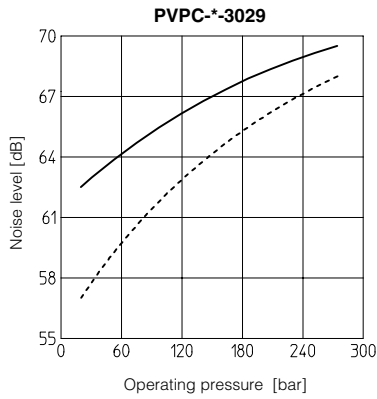

6.2 Operating limits

- 1 = Volumetric efficiency
- 2 = Overall efficiency
- 3 = Flow versus pressure curve
- 4 = Power consumption with full flow
- 5 = Power consumption at pressure compensation

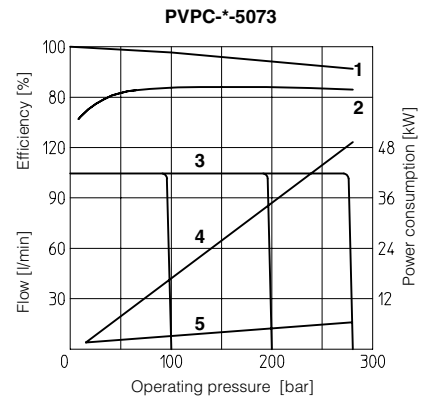
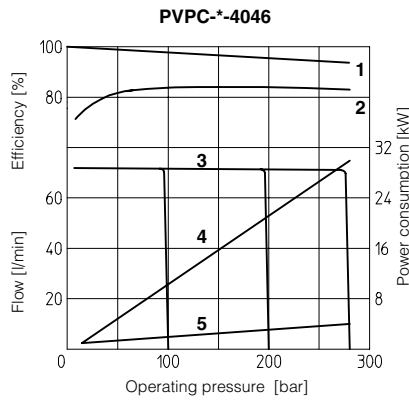
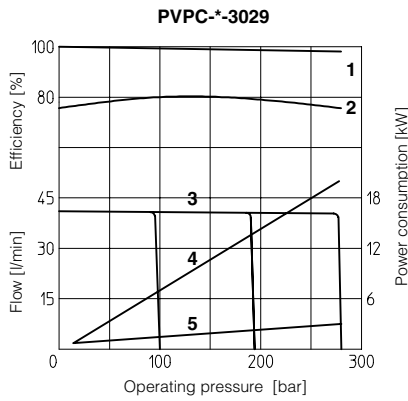

6.3 Response times

6.3.1 Response times and pressure peak due to variation 0% → 100% → 0% of the pump displacement, obtained with an instantaneously opening and shut-off of the delivery line.

Pump type	T1 (ms)	T2 (ms)
PVPC*-3029	31	19
PVPC*-4046	44	20
PVPC*-5073	50	25

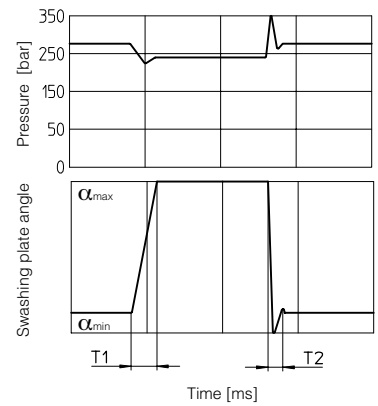

6.3.2 Variation of inlet pressure and reduction of displacement with increasing speed rating

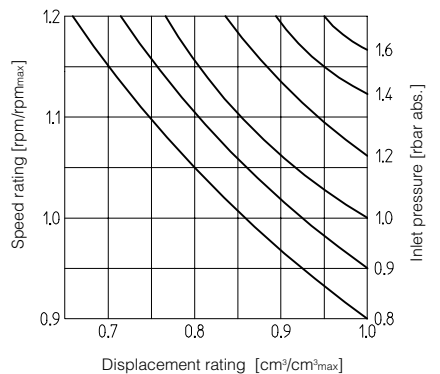

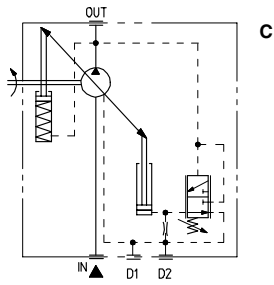

Manual pressure compensator

The pump displacement decreases when the line pressure approaches the setting pressure of the compensator. The pump supplies only the fluid required by the system. Pressure may be steplessly adjusted at the pilot valve. Compensator setting range: 20 ÷ 350 bar. Compensator standard setting: 280 bar.

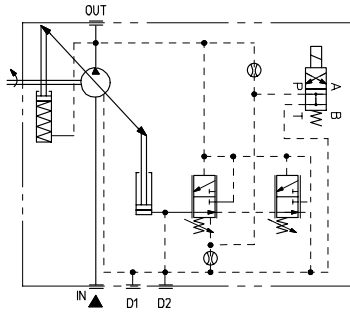
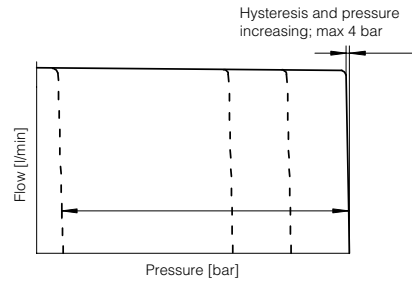

Manual pressure compensator with venting

As C plus venting function, when a long unloading time is required and heat generation and noise have to be kept at lowest level. Compensator setting range: 20 ÷ 350 bar. Compensator standard setting: 280 bar.

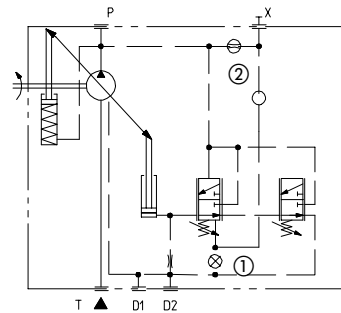
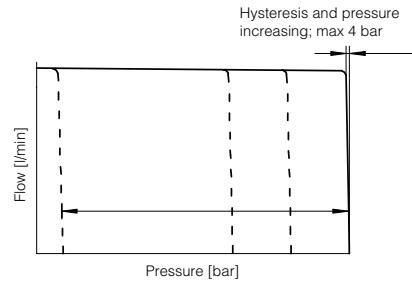

Remote pressure compensator

As C, but with remote setting of the compensator by means of a pressure relief valve on the piloting line X. This version can be obtained from version L using a blind plug UNI 5923 M4x12 in pos. ① and a restrictor M4 drilled ø 0,75 mm in pos. ②. Compensator setting range: 20 ÷ 350 bar. Compensator standard setting: 280 bar.

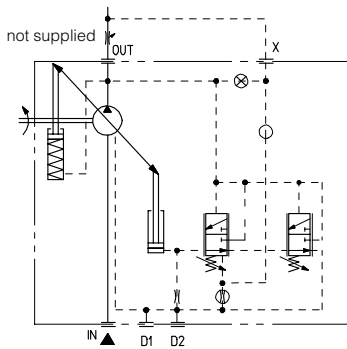
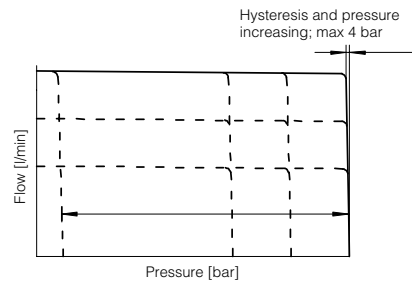

Load sensing

The pump displacement is automatically adjusted to maintain a constant (load independent) pressure drop across an external throttle. Changing the throttle regulation, the pump flow is consequently adjusted. Load sensing control always incorporates an hydraulic compensator to limit the maximum pressure. Compensator setting range: 20 ÷ 350 bar. Compensator standard setting: 280 bar. Differential pressure setting range: 10 ÷ 40 bar. Differential pressure standard setting : 14 bar.

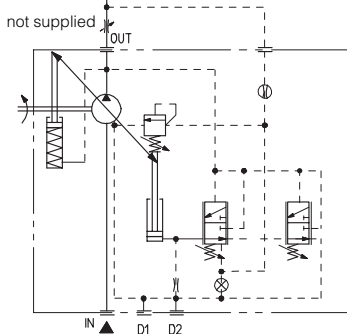
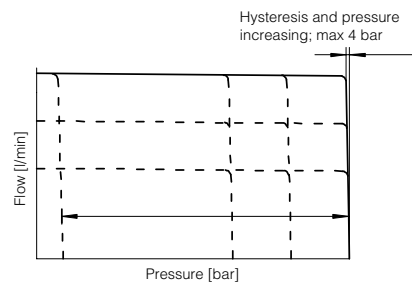

Constant power

In order to achieve a constant drive torque with varying operating pressure. The swashing angle and therefore the outlet flow is varied so that the product of flow and pressure remains constant. For the best regulation, minimum working pressure is 80 bar. While selecting LW control, the required value of power must be communicated with the order (ex. 10 kW at 1450 rpm).

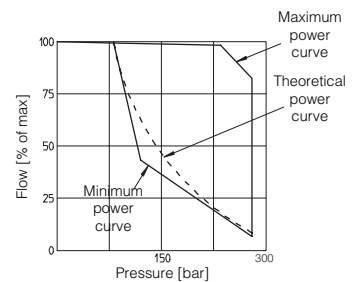

8 DIMENSIONS OF PVPC-⁺-3029: BASIC VERSION "C" CONTROL

PORTS DIMENSION

IN = Flange SAE 3000 1 1/4"

OUT = Flange SAE 6000 3/4"

D1, D2 = 1/2" BSPP

① = Regulation screw for max displacement 1,5 cm³/rev per turn. Adjustable range 50% to 100% of max displacement.
In case of double pump the regulation screw is not always available, please contact our technical office.

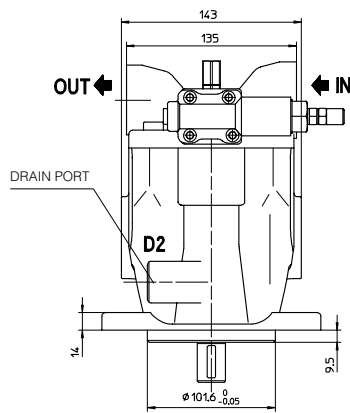
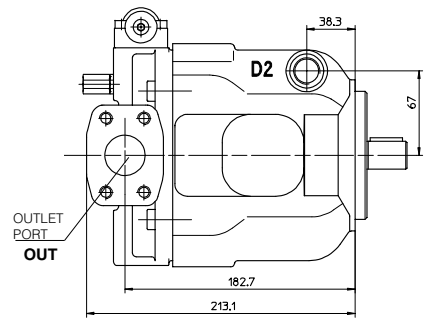
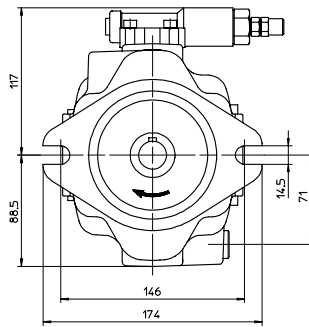
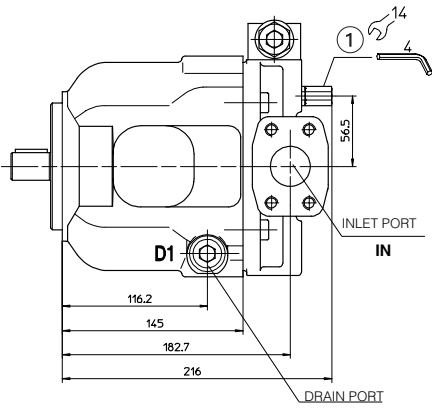

Mass: 18 kg

SHAFT TYPE "1"

SHAFT TYPE "5"

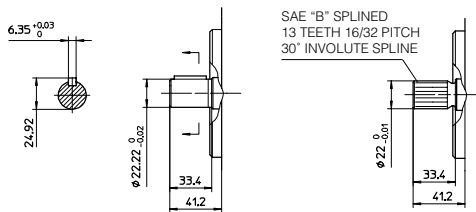

INTERMEDIATE FLANGE SAE "A" FOR PFE-31

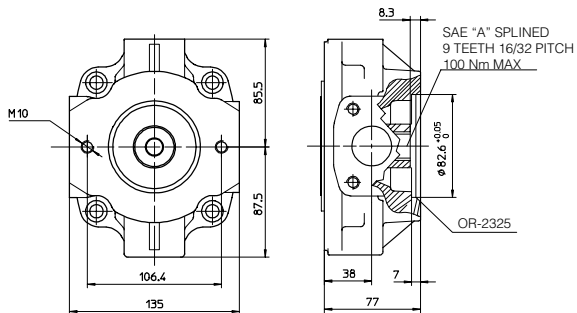

INTERMEDIATE FLANGE SAE "B" FOR PFE-41

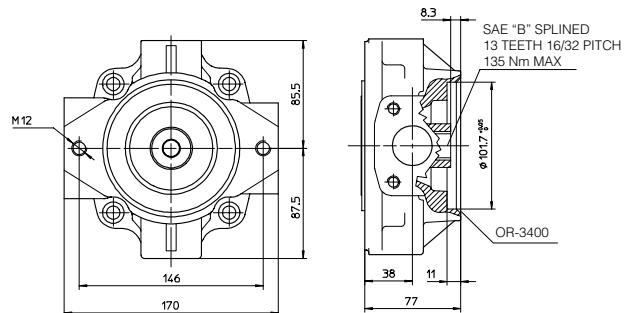

Drawing shows pumps with clockwise rotation (option D); pumps with counterclockwise rotation (option S) will have inlet and outlet ports inverted

9 DIMENSIONS OF PVPC-*4046: BASIC VERSION "C" CONTROL

PORTS DIMENSION

IN = Flange SAE 3000 1 1/2"

OUT = Flange SAE 6000 1"

D1, D2 = 1/2" BSPP

① = Regulation screw for max displacement 2.2 cm³/rev per turn. Adjustable range 50% to 100% of max displacement.
In case of double pump the regulation screw is not always available, please contact our technical office.

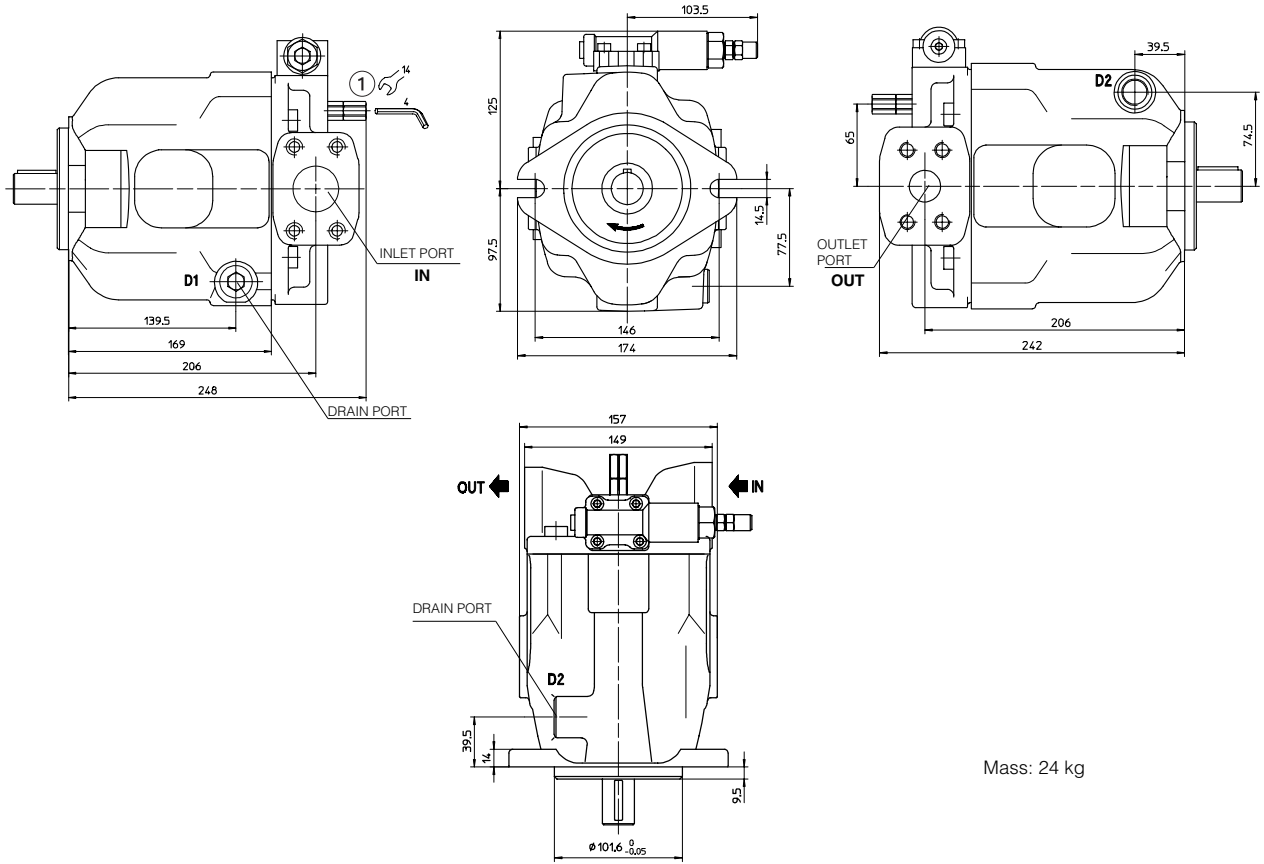

SHAFT TYPE "1"

SHAFT TYPE "5"

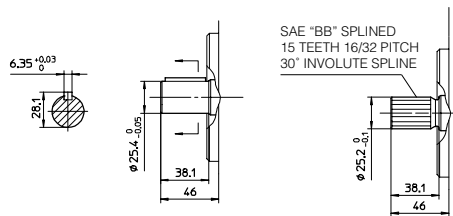

INTERMEDIATE FLANGE SAE "A" FOR PFE-31

INTERMEDIATE FLANGE SAE "B" FOR PFE-41

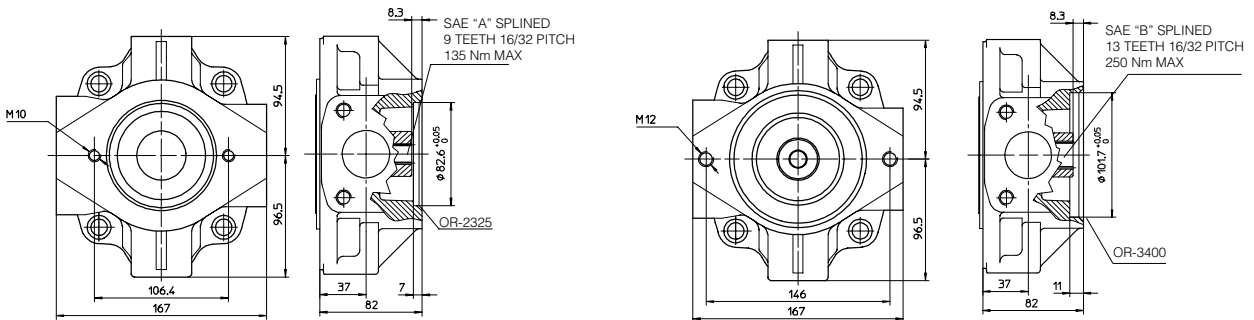

Drawing shows pumps with clockwise rotation (option D); pumps with counterclockwise rotation (option S) will have inlet and outlet ports inverted

10 DIMENSIONS OF PVPC-⁺5073: BASIC VERSION "C" CONTROL

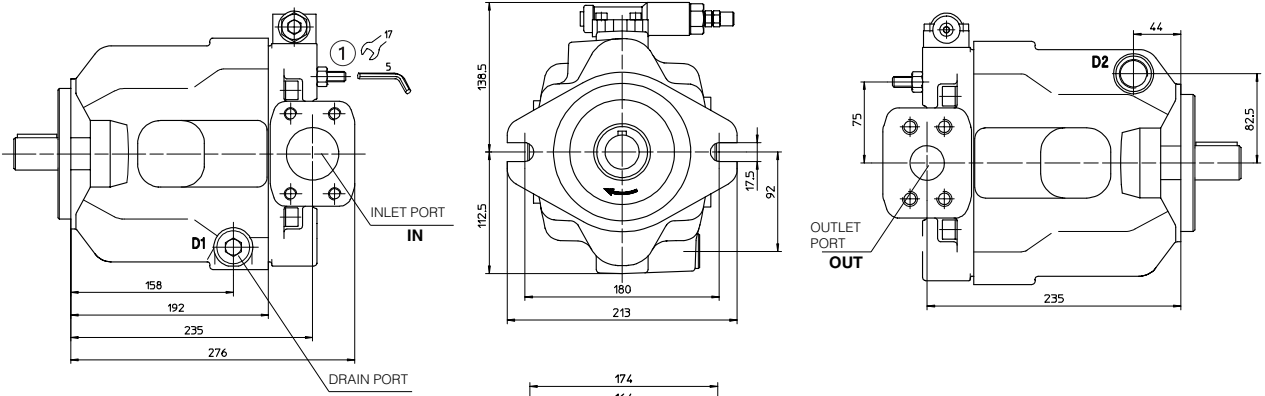

PORTS DIMENSION

IN = Flange SAE 3000 2"
 OUT = Flange SAE 6000 1 1/4"
 D1, D2 = 3/4" BSPP
 ① = Regulation screw for max displacement
 3,2 cm³/rev per turn.
 Adjustable range 50% to 100% of max displacement.
 In case of double pump the regulation screw is not always available, please contact our technical office.

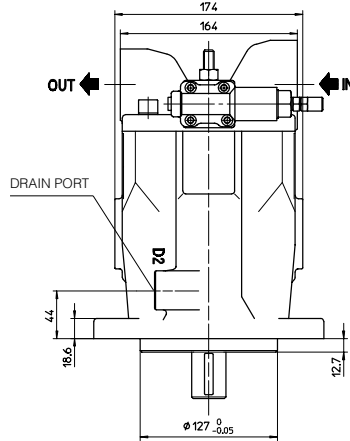

Mass: 33 kg

SHAFT TYPE "1"

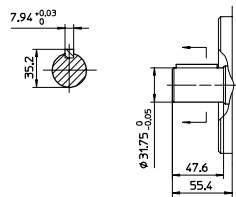

SHAFT TYPE "5"

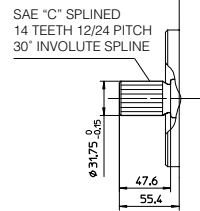

INTERMEDIATE FLANGE SAE "A" FOR PFE-31

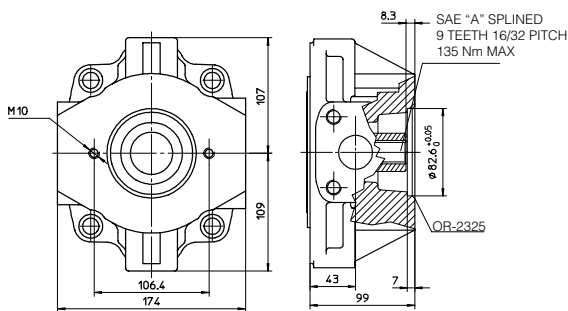

INTERMEDIATE FLANGE SAE "B" FOR PFE-41

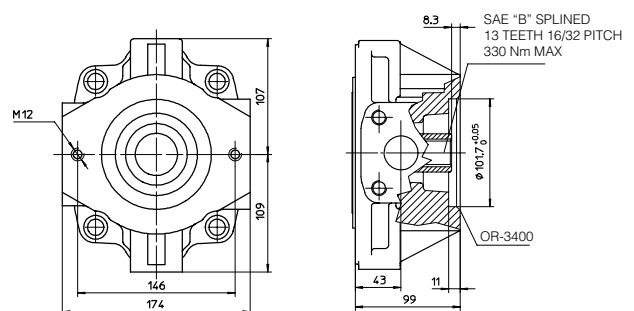

INTERMEDIATE FLANGE SAE "C" FOR PFE-51

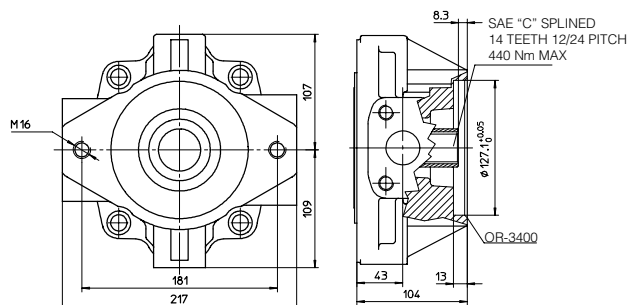

Drawing show pumps with clockwise rotation (option D); pumps with counterclockwise rotation (option S) will have inlet and outlet ports inverted

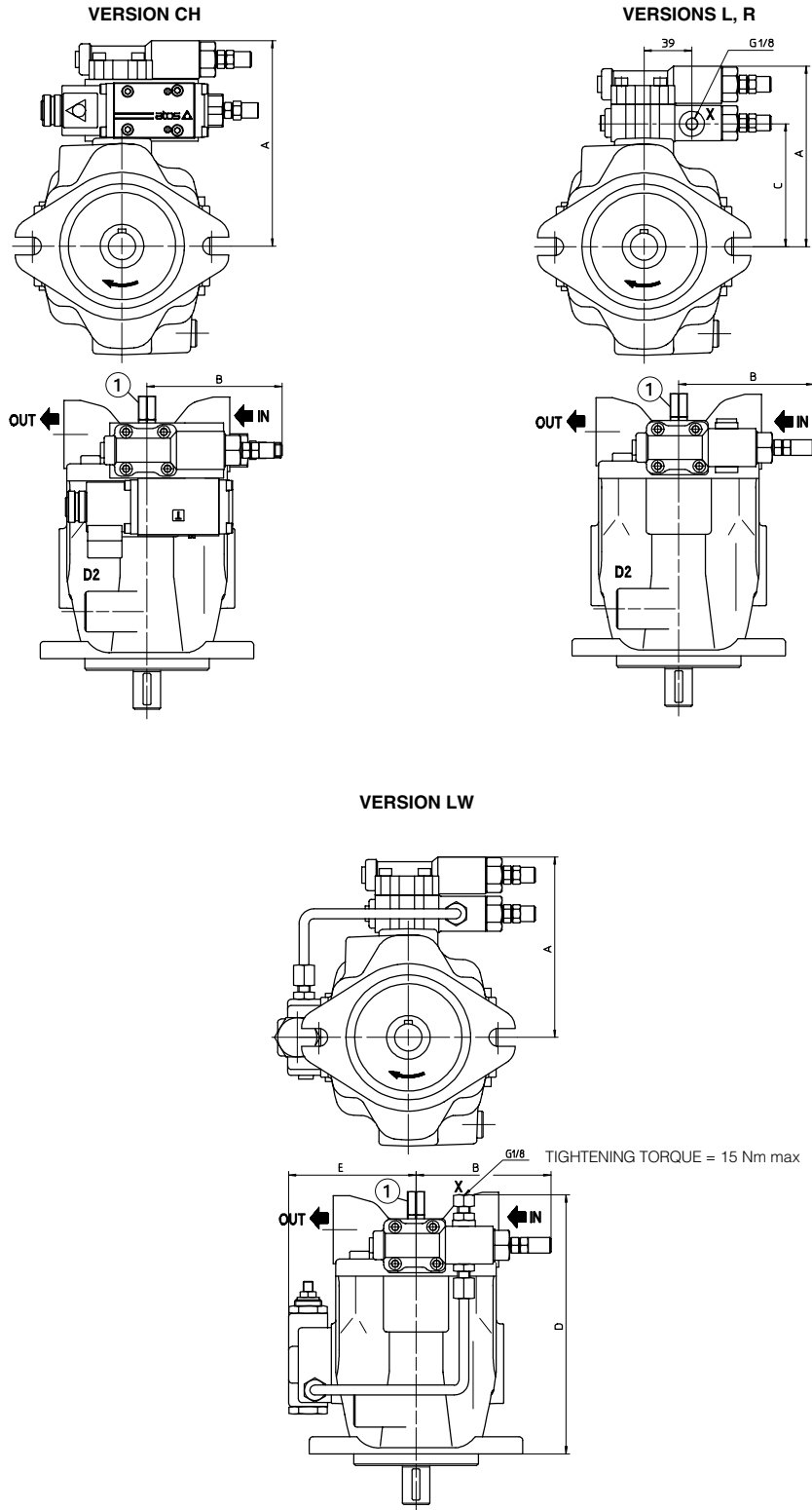

① = Regulation screw for max displacement. Adjustable range 50% to 100% of max displacement (not available for versions SLER, SLER/X, PES, PERS and PERS/X).
 In case of double pump the regulation screw is not always available, please contact our technical office.

Drawing shows pumps with clockwise rotation (option D): pumps with counterclockwise rotation (option S) will have inlet and outlet ports inverted and also the consequently

Pump type	Version	A	B	C	D	E	Mass (kg)
PVPC-*-3029	CH	168	111	-	-	-	22
	L -R	144	111	100	-	-	19,2
	LW	144	111	-	211	104	20
PVPC-*-4046	CH	177	111	-	-	-	28
	L -R	153	111	109	-	-	25,2
	LW	153	111	-	235	111	26
PVPC-*-5073	CH	1190	111	-	-	-	36,9
	L -R	166	111	122	-	-	34,2
	LW	166	111	-	258	120	35